

# MARKING SCHEME

2012

CLASS XII  
SCIENCE SUBJECTS



CENTRAL BOARD OF SECONDARY EDUCATION  
DELHI

CBSE, Delhi-110301

November, 2012 : 250 Copies

Price : Rs.

Manuscript as such highlights the main value points and does not represent a complete ideal answer.  
Manuscript may vary from time to time and year to year.

Published by Secretary, C.B.S.E. 'Shiksha Kendra', 2, Community Centre, Preet Vihar, Delhi - 110301.  
Laser typesetting and Printed by Akashdeep Printers, Daryaganj, New Delhi - 110002

## PREFACE

CBSE as a pace setting national Board has constantly been striving to design its evaluation process in a manner that it is used as a powerful means of influencing the quality of teaching and learning in the classroom situation. Also, it has to be so designed that it provides constant feedback regarding the effectiveness of the course content, classroom processes and the growth of individual learners besides the appropriateness of evaluation procedures.

As a move in this direction, CBSE started the practice of publishing the Marking Schemes with twin objectives in mind-(i) making the system more transparent and at the same time, (ii) ensuring high degree of reliability in scoring procedure.

Who are the markers of answer scripts? How do they mark the answer scripts? How can it be ensured that marking is fair, objective and reliable? Questions of these types naturally arise in the minds of candidates appearing in the public examination. These questions are equally pertinent to the teachers who are not adequately exposed to the CBSE system of marking.

Answer Scripts marking is a specialised job. It is assigned to teachers-PGTs for Class XII and TGTs for Class X who are in direct touch with the subject and have a minimum of 3 years experience of teaching the subject at that level. Appointment of examiners is made in accordance with the well-defined norms. Markers examine scripts with the help of detailed guidelines called the 'Marking Schemes'.

It is this tool (Marking Scheme) alongwith the extensive supervisory checks and counter-checks through which CBSE tries to ensure objective and fair marking. The present publication is being brought out with a view to serving the following objectives :

- (i) To give an opportunity to the teachers and students to look into the Marking Schemes that were developed by the Board and supplied to the evaluators in 2012 main examination in some selected main subjects.
- (ii) To receive feedback and suggestions from institutions/subject teachers on the utility and further improvement of Marking Schemes.
- (iii) To encourage institutions to undertake similar exercise of developing marking schemes for classes other than those covered by the Board's examination with a view to increasing teachers' responsiveness to them as the essential tools of evaluation.

## HOW TO USE

Teachers and the students preparing for Class XII examination of the Board constitute the primary interest-group of this publication. Marking Schemes of Question Papers in the subjects of English Core, Functional English, Mathematics, Physics, Chemistry, Biology, Bio-Technology, Informatics Practices, Computer Science, Engineering Drawing and Multimedia & Web Technology administered in Delhi and Outside Delhi during the 2012 main examination have been included in this document. Some tips on their usage are given below :

**(a) To Teachers :**

- Go through the syllabus and the weightage distribution for the subject carefully.
- Read the question paper to find out how far the question paper set subscribes to the prescribed design. Grade every question by difficulty level for students who have taken the main Board examination.
- Consult the 'Marking Scheme' for each question, with reference to steps into which answers and awards have been divided.
- Work out concrete suggestions for the Board.

**(b) To Students :**

- Study each question carefully, comprehend them and write down the main points of the answer and note down their difficulties for clarification.
- Examine a question in conjunction with the Marking Scheme and find out the proximity of the answer to that suggested in the Marking Scheme.

We urge the teachers to encourage their students to make use of this publication

**M.C. SHARMA**  
CONTROLLER OF EXAMINATIONS

# भारत का संविधान

## उद्देशिका

हम, भारत के लोग, भारत को एक ' [सम्पूर्ण प्रभुत्व-संपन्न समाजवादी पंथनिरपेक्ष लोकतंत्रात्मक गणराज्य] बनाने के लिए, तथा उसके समस्त नागरिकों को:

सामाजिक, आर्थिक और राजनैतिक न्याय,  
विचार, अभिव्यक्ति, विश्वास, धर्म

और उपासना की स्वतंत्रता,  
प्रतिष्ठा और अवसर की समता

प्राप्त कराने के लिए,  
तथा उन सब में,

व्यक्ति की गरिमा और <sup>2</sup> [राष्ट्र की एकता  
और अखण्डता] सुनिश्चित करने वाली बंधुता

बढ़ाने के लिए

दृढसंकल्प होकर अपनी इस संविधान सभा में आज तारीख 26 नवम्बर, 1949 ई० को एतद्द्वारा इस संविधान को अंगीकृत, अधिनियमित और आत्मार्पित करते हैं।

- 
1. संविधान (बयालीसवां संशोधन) अधिनियम, 1976 की धारा 2 द्वारा (3.1.1977) से "प्रभुत्व-संपन्न लोकतंत्रात्मक गणराज्य" के स्थान पर प्रतिस्थापित।
  2. संविधान (बयालीसवां संशोधन) अधिनियम, 1976 की धारा 2 द्वारा (3.1.1977 से), "राष्ट्र की एकता" के स्थान पर प्रतिस्थापित।
- 

## भाग 4 क

### मूल कर्तव्य

51 क. मूल कर्तव्य - भारत के प्रत्येक नागरिक का यह कर्तव्य होगा कि वह -

- (क) संविधान का पालन करें और उसके आदर्शों, संस्थाओं, राष्ट्र ध्वज और राष्ट्र गान का आदर करें;
- (ख) स्वतंत्रता के लिए हमारे राष्ट्रीय आंदोलन को प्रेरित करने वाले उच्च आदर्शों को हृदय में संजोए रखें और उनका पालन करें;
- (ग) भारत की प्रभुता, एकता और अखंडता की रक्षा करें और उसे अक्षुण्ण रखें;
- (घ) देश की रक्षा करें और आह्वान किए जाने पर राष्ट्र की सेवा करें;
- (ङ) भारत के सभी लोगों में समरसता और समान भ्रातृत्व की भावना का निर्माण करें जो धर्म, भाषा और प्रदेश या वर्ग पर आधारित सभी भेदभाव से परे हों, ऐसी प्रथाओं का त्याग करें जो स्त्रियों के सम्मान के विरुद्ध हैं;
- (च) हमारी सामासिक संस्कृति की गौरवशाली परंपरा का महत्व समझें और उसका परिरक्षण करें;
- (छ) प्राकृतिक पर्यावरण की जिसके अंतर्गत वन, झील, नदी, और वन्य जीव हैं, रक्षा करें और उसका संवर्धन करें तथा प्राणि मात्र के प्रति दयाभाव रखें;
- (ज) वैज्ञानिक दृष्टिकोण, मानववाद और ज्ञानार्जन तथा सुधार की भावना का विकास करें;
- (झ) सार्वजनिक संपत्ति को सुरक्षित रखें और हिंसा से दूर रहें;
- (ञ) व्यक्तिगत और सामूहिक गतिविधियों के सभी क्षेत्रों में उत्कर्ष की ओर बढ़ने का सतत प्रयास करें जिससे राष्ट्र निरंतर बढ़ते हुए प्रयत्न और उपलब्धि की नई ऊंचाईयों को छू लें।

# THE CONSTITUTION OF INDIA

## **PREAMBLE**

**WE, THE PEOPLE OF INDIA**, having solemnly resolved to constitute India into a <sup>1</sup> **[SOVEREIGN SOCIALIST SECULAR DEMOCRATIC REPUBLIC]** and to secure to all its citizens :

**JUSTICE**, social, economic and political;

**LIBERTY** of thought, expression, belief, faith and worship;

**EQUALITY** of status and of opportunity; and to promote among them all

**FRATERNITY** assuring the dignity of the individual and the <sup>2</sup> [unity and integrity of the Nation];

**IN OUR CONSTITUENT ASSEMBLY** this twenty-sixth day of November, 1949, do **HEREBY ADOPT, ENACT AND GIVE TO OURSELVES THIS CONSTITUTION.**

1. Subs, by the Constitution (Forty-Second Amendment) Act. 1976, sec. 2, for "Sovereign Democratic Republic (w.e.f. 3.1.1977)
2. Subs, by the Constitution (Forty-Second Amendment) Act. 1976, sec. 2, for "unity of the Nation (w.e.f. 3.1.1977)

---

# THE CONSTITUTION OF INDIA

## **Chapter IV A**

### **Fundamental Duties**

#### **ARTICLE 51A**

**Fundamental Duties** - It shall be the duty of every citizen of India-

- (a) to abide the Constitution and respect its ideals and institutions, the National Flag and the National Anthem;
- (b) to cherish and follow the noble ideals which inspired our national struggle for freedom;
- (c) to uphold and protect the sovereignty, unity and integrity of India;
- (d) to defend the country and render national service when called upon to do so;
- (e) To promote harmony and the spirit of common brotherhood amongst all the people of India transcending religious, linguistic and regional or sectional diversities; to renounce practices derogatory to the dignity of women;
- (f) to value and preserve the rich heritage of our composite culture;
- (g) to protect and improve the natural environment including forests, lakes, rivers, wild life and to have compassion for living creatures;
- (h) to develop the scientific temper, humanism and the spirit of inquiry and reform;
- (i) to safeguard public property and to abjure violence;
- (j) to strive towards excellence in all spheres of individual and collective activity so that the nation constantly rises to higher levels of endeavour and achievement.

# CONTENTS

## *Senior School Certificate Examination (XII)*

### Marking Scheme

	Page No.
1. English Core .....	1-42
2. Functional English .....	43-90
3. Mathematics .....	91-124
4. Physics .....	125-181
5. Chemistry .....	182-214
6. Biology .....	215-247
7. Bio-technology .....	248-262
8. Informatics Practices .....	263-322
9. Computer Science .....	323-422
10. Engineering Graphics .....	423-448
11. Multimedia and Web Technology .....	449-502

**LIST OF COORDINATORS/SUBJECT EXPERTS/REPRESENTATIVES  
OF THE REGIONS FOR UPDATION/FINALISATION OF THE  
MARKING SCHEME FOR THE SENIOR SCHOOL CERTIFICATE  
EXAMINATION, 2012**

<i>S.No. Name of the Coordinator/Subject Experts</i>	<i>S.No. Name of the Coordinator/Subject Experts</i>
<b>ENGLISH CORE</b>	
1. Dr. Usha Ram Principal Laxman Public School Hauz Khas, New Delhi-16	7. Br. Felix Martis Loyola High School, Khurji, PO Sadaqat Ashram, Patna, Bihar
2. Dr. Opkar Singh Retd. Prof. 121, Sahyog Appartments Mayur Vihar Phase-I Delhi-110091	8. Sh. Vikram Joshi Principal, Jawahar Navodaya Vidyalaya, Rudrapur, Udham Singh Nagar, Utrakhand-263153
3. Mrs. Bella Bhateja, PGT G. D. Goenka Pub. School Vasant Kunj, New Delhi	9. Mr. S.P. Chand PGT Global Gurukul Institute School, Mani Majra, Chandigarh
4. Dr. Sanjeevan Bose PGT Scindia School The Fort, Gwalior-474008	10. Mr. D.N.Tiwari PGT Laxman Public School Hauz Khas, New Delhi - 16
5. Ms. Vandana Kapoor Principal S.L.S. DAV Public School Mausam Vihar Delhi	11. Shri Dastidar Principal Army School, Narangi, PO-Satgaon, Guwahati - 781027
6. Mrs. Kanti Ramakrishnan Vice Principal Chinmaya Vidyalaya, 9 B Taylors Road, Kilpauk, Chennai-600011	12. Ms. Sudesh Arora Laxman Public School Hauz Khas, New Delhi - 16
	13. Sh. Navin Sharma Laxman Public School Hauz Khas, New Delhi - 16



---

*S.No. Name of the Coordinator/Subject Experts*

---

**FUNCTIONAL ENGLISH**

1. Mrs. Annie Koshy  
Principal  
St. Mary's School  
B-II Block, Safdarjung Enclave  
New Delhi
2. Mrs. Usha Ram  
Principal  
Laxman Public School  
Hauz Khas, New Delhi-110016
3. Mrs. Malini Khatri  
Modern School  
Barakhamba Road  
New Delhi-110001
4. Ms. Neena Kaul  
St. Mary's School  
B-II Block, Safdarjung Enclave  
New Delhi
5. Mrs. S. Lahiri  
St. Mary's School  
B-II Block, Safdarjung Enclave,  
New Delhi
6. Lakshmi Srinivasan  
Principal,  
P. S. Sr. Sec. School,  
33, Alarmlingapuram  
Mylapore, Chennai-600004
7. Shri P. J. Peter  
PGT  
Laxman Public School  
Hauz Khas, New Delhi
8. Mrs. Shailja Jaiswal  
PGT  
Delhi Public School  
Site No. 3, Meerut Road,  
Ghaziabad - UP-201003

---

*S.No. Name of the Coordinator/Subject Experts*

---

**MATHEMATICS**

1. Mrs. Anita Sharma  
Principal  
S.D. Public School  
BU Block, Pitampura,  
Delhi-110034
2. Dr. V. P. Gupta  
Retired Professor  
Kala Vihar Appartments,  
Mayur Vihar, Phase-1  
Delhi
3. Sh. G. D. Dhall  
K-171, LIC Colony  
Syed Nangloi Village  
Delhi
4. Sh. S.N. Chibber  
Principal (Retd.)  
B-330, Saraswati Vihar  
Delhi
5. Sh. J. C. Nijhawan  
Rtd. Principal  
C-51, Maharana Pratap Enclave,  
Delhi-110034
6. Mr. Rajpal,  
PGT  
Pratibha Vikas Vidyalaya,  
Gandhi Nagar, Delhi-110051  
(218, Maitrye Appts.  
I.P. Extn., Patparganj, Delhi)
7. Sh. M.M. Alam  
Vice Principal  
St. John's Sr. Sec. School,  
Bundi Road,  
Kota-324008 (Rajasthan)

<i>S.No. Name of the Coordinator/Subject Experts</i>	<i>S.No. Name of the Coordinator/Subject Experts</i>
8. Sh. D. R. Sharma, Vice-Principal JNV, Mouli Panchkul	14. Dr. K.C. Satpathy Principal, DAV Pub, School, Chandrasekharapur, Bhubaneshwar, Khordha Odisha-751021
9. Sh. Mongal Saha, Vice Principal, Army School, Narangi, PO-Satgaon, Guwahati-781027	15. Sh. V.P. Singh Retired Principal 2610 A, Street No.9 Bihari Colony Shahdara, Delhi-32
10. Mr. C. Sathyamurthy Principal Chinmaya Vidyalaya 9-B, Taylore Road Kilpauk Chennai-600010	16. Sh. J.P. Singh A-64, F-3, Ram Prastha Ghaziabad (U.P)
11. Sh. S. D. Arora, Principal, Kendriya Vidyalaya No.1 Civil Lines, Rae Bareli, U.P.-2299001	17. Sh. Parveen Kumar PGT S. D. Public School, BU Block, Pitampura Delhi
12. Mrs. Saroj Gupta, Principal, DTEA Sr. Sec. School, Sector-4, R.K. Puram, Delhi	18. Sh. Ajay Marwaha PGT (Mathematics) S.D. Public School BU Block Pitampura, Delhi
13. Sh. R.N. Chaubey Jawahar Lal Memorial Sr. Sec. School Digwadih No. 12, P.O. Pathardih, Dhanbad, Jharkhand	<b>PHYSICS</b> 1. Sh. D.K. Bedi Principal Apeejay School, Road No. 42, Sainik Vihar, Pitampura Delhi-110034

<i>S.No. Name of the Coordinator/Subject Experts</i>	<i>S.No. Name of the Coordinator/Subject Experts</i>
2. Prof. V.S. Bhasin B4/46 Paschim Vihar, New Delhi	9. Sh. Nilakantha Panigrahi Vice Principal Sai International School, 5A, Chandaka Indust. Estate, Infocity Road, Bhubaneswar. Khurda, Bhubaneswar (Odisha)
3. Sh. N.K. Sehgal A-94/1, SFS Flats, Saket, New Delhi	10. Sh. Surjan Singh PGT CRPF Public School, Sector-XIV, Rohini, Delhi-110085
4. Sh. G. Giri Head Master Modern School Barakhamba Road New Delhi	11. Mrs. Kiran Nayak Apeejay School, Road No. 42, Sainik Vihar, Pitampura Delhi
5. Sh. Suraj Prakash Retd. Principal QU-290 - B, Chitrakoot Apptts. Pitampura Delhi - 110034	12. Mrs. Ravinder Kaur PGT Govt. Model Sr. Sec. School Sector 33 Chandigarh
6. Sh. R.S. Thakur, Vice Principal HE Vikram Hr. Sec. School, BHEL, Piplani Bhopal - 462021	<b>CHEMISTRY</b>
7. Mr. L. Neelakanta Pillai, Principal Kola Perumal Chetty Vaishnav Sr. Sec. School 815, EVR Periyar High Road, Arumbakkam Chennai, 600106	1. Sh.S.K.Munjal Principal St. Margaret Pub. School D-Block Prashant Vihar Delhi-110085
8. Mr. Dinesh Bartwal, Vice Principal Doon International School, 32, Curzon Road Dalanwala Dehradun Uttarakhand-248001	2. Dr. K.N. Uppadhyay, 326 SFS Flats Ashok Vihar Phase-IV Delhi-52
	3. Prof. R.D. Shukla, 40, Delux Apptt. B-5, Vasundhara Enclave Delhi-110096

<i>S.No. Name of the Coordinator/Subject Experts</i>	<i>S.No. Name of the Coordinator/Subject Experts</i>
4. Mr. D.A. Mishra Retd. Principal B-203, Saraswati Vihar, Delhi-110034	11. Dr. (Mrs) Sangeeta Bhatia Principal KIIT World School Pitampura, Near Club, Delhi-34
5. Sh. Rakesh Dhawan PGT St. Margaret Public School Prashant Vihar Delhi	12. Dr. D.R. Singh Jawahar Vidya Mandir Shyamli, Ranchi, Jharkhand
6. Sh. Deshbir Singh, PGT St. Paul's Hr Sec. School Boundary Road, Indore-452001	13. Dr. Mrs. Bhagwati Nayak Principal DAV Public School, Unit-8, Post office Naya Palli Bhubneshwar-751012 (Odisha)
7. Sh. Avinash Kumar Vohra PGT Govt. Model Sr. Sec. School Sector-35, Chandigarh	<b>BIOLOGY</b>
8. Sh. R.C. Gond Principal Kendriya Vidyalaya No. 2, Itanagar, Distt. Pampumpare, Arunachal Pradesh-791111.	1. Mrs. Rachna Gupta, Headmistress Delhi Public School Sector C Poket 5, Vasant Kunj, New Delhi
9. Mr. K.M. Abdul Raheem Vice Principal SPDH Sindhi Model Sr. Sec. School 1, Danodara Street Kellys, Chennai Tamilnadu-600010	2. Sh. Y.P. Purang Retd. ADE C2/113, Janakpuri, New Delhi-58
10. Sh. A.N. Pandit Principal Godwin Public School Rohta Road, P.O. Fazalpur Meerut (U.P.) - 250001	3. Mrs. Rita Talwar Retd. Principal 54, Khan Market New Delhi
	4. Sh. Virendra Srivastava B-3B/95 B Janakpuri New Delhi-110058

<i>S.No. Name of the Coordinator/Subject Experts</i>	<i>S.No. Name of the Coordinator/Subject Experts</i>
5. Ms. Shivani Goswami, 563, Golf Vista Appts, Alpha-II, Sector, Greater Noida, Gautam Budh Nagar (U.P.)	12. Ms. Bandana Lazarus Delhi Public School, Vasant Kunj, New Delhi-70
6. Smt. Kamaljeet Kaur PGT Govt. Model Sr. Sec. School Sector-18 Chandigarh	13. Sh. S. K. Joshi Principal Vidya Sagar School Bichili Mardana Indore, Madhya Pradesh
7. Sh. Laxmi Narayanan, Principal, Kendriya Vidyalaya, AFS, Digaru, Sonapur, Kamrup, Assam-782402	<b>BIO-TECHNOLOGY</b>
8. Mrs. Margarette Davidraj Principal Bakthavatsalam Vidyashram 14, 31st Street, TNHB Colony, Periyaar Nagar, Korattur, Chennai-80	1. Dr. K. Nirmala Reader Department of Bio-Chemistry Daulat Ram College University of Delhi
9. Smt. Neeta Rastogi Principal Sadhu Vaswani Int. School for Girls 2nd Street, Shanti Niketan New Delhi	3. Dr. J.S. Viridi Department of Microbiology University of Delhi South Campus Benito Juarez Road, Dhaula Kuan New Delhi
10. Dr. U.S. Prasad DAV Public School Cantonment Area, Gaya (Bihar)	3. Smt. Madhumati Bhaskarwar PGT G.D. Goenka Public School Sector 3, Pocket - 8 & 9 Vasant Kunj, New Delhi
11. Sh. Shankar Bardhan, Vice Principal, Hem Sheela Model School Jawahar Lal Nehru Avenue, Durgapur, Barddhaman, West Bengal-713214	4. Ms. Vaishali Aggarwal PGT-Bio-Technology, SLS DAV Public School Mausam Vihar Delhi

<i>S.No. Name of the Coordinator/Subject Experts</i>	<i>S.No. Name of the Coordinator/Subject Experts</i>
5. Ms. Shashi Bajaj, B-278, Saraswati Vihar, Pitampura New Delhi	4. Dr. Richa Verma PGT KIIT World School Near Club Pitampura, Delhi
6. Dr. Sunita Joshi, Deptt. of Biochem. DRC, Delhi University.	5. Mrs. Nancy Sehgal PGT Mata Jai Kaur Public School Ashok Vihar, Delhi
7. Mrs. Chhonkan, Delhi Public School, R.K. Puram Sector-XII, New Delhi	6. Mrs. Bharti Arora PGT. S.D. Public School Sector-32, Chandigarh
8. Mrs. Shikha Gupta JD Tytler School New Rajendra Nagar, New Delhi.	7. Mr. K.V. Krishan Kumar PGT PS Sr. Sec. School 33, Almelmangapuram Mylapore, Chennai-600004
<b>INFORMATICS PRACTICE</b>	
1. Sh. Mukesh Kumar PGT Delhi Public School Sec-XII, R.K. Puram, New Delhi	<b>COMPUTER SCIENCE</b>
2. Sh. M.P.S. Bhatia NSIT Dwarka, Delhi	1. Sh. Mukesh Kumar PGT Delhi Public School See-XII, R.K. Puram New Delhi
3. Sh. R.K. Tiwari PGT Vivekanand School D Block, Anand Vihar Delhi	2. Sh. M.P.S. Bhatia NSIT Dwarka, Delhi

---

*S.No. Name of the Coordinator/Subject Experts*

---

3. Sh. R.K. Tiwari  
PGT  
Vivekanand School  
D Block, Anand Vihar  
Delhi
4. Mrs. Sushila Mohan Dass  
3043, Shobha Amethyst,  
Whitefield Main Road,  
Bangalore
5. Sh. Mohitendra Dey  
Delhi Public School  
RK Puram, Sector-12  
New Delhi-110022
6. Sh. S. Sriram  
HOD  
Mayo College  
Ajmer, Rajasthan-305008
7. Smt. Manjeet Johar  
PGT  
Global Gurukul Int. School,  
I.T. Park, Mani Majra,  
Chandigarh
8. Mrs. Usha Vishwanathan  
PGT  
Sri Sankara Sr. Sec. School,  
No. 9/21 Vasantha Press Road,  
Adyar, Chennai  
Tamilnadu-600020

---

*S.No. Name of the Coordinator/Subject Experts*

---

9. Smt. Divya Jain  
74, Jai Apartments  
I P Extension  
Delhi-92
10. Ms. Purvi Srivastava  
Ganga International School  
Hiran Kudna, Rohtak Road,  
New Delhi-110041
11. Shri Ashok Kumar Goel  
ED-50A, Pitampura  
Delhi

**ENGINEERING GRAPHICS**

1. Mr. R.K. Gupta  
Head of the School  
Jain Sr. Sec. School  
Daryaganj  
New Delhi
2. Sh. Arvind Kumar Singh Chauhan  
Modern School  
Vasant Vihar  
New Delhi
3. Prof. N. L. Sachdeva  
Rtd. Prof. from DCE  
52-D, BW Block  
Shalimar Bagh  
Delhi

---

*S.No. Name of the Coordinator/Subject Experts*

---

4. Sh.R.P Chaurasiya  
Vice Principal (Retd.)  
61/B-7, Sector-04, Rohini
5. Sh. Hitesh Gupta  
G.B. Pant S.B. Vidyalaya  
Sriniwaspuri  
New Delhi
6. Sh. Surjit Chatterjee  
Bal Bharti Pub. School  
Ganga Ram Hospital Marg  
New Delhi

---

*S.No. Name of the Coordinator/Subject Experts*

---

**MULTIMEDIA & WEB TECHNOLOGY**

1. Sh. Mukesh Kumar  
Delhi Public School  
Sector-XII, R.K. Puram  
New Delhi
2. Smt. Gurpreet Kaur  
G.D. Goenka Public School  
Vasant Vihar  
New Delhi
3. Sh. M.P.S. Bhatia  
NSIT, Sector-3  
Dwarka, Delhi



# ENGLISH (Core)

*Time allowed : 3 hours*

*Maximum marks : 100*

## **General Instructions:**

- (i) *This paper is divided into three Sections: A, B and C. All the sections are compulsory.*
- (ii) *Separate instructions are given with each section and question, wherever necessary. Read these instructions very carefully and follow them faithfully.*
- (iii) *Do not exceed the prescribed word limit while answering the questions.*

## **QUESTION PAPER CODE 1/1/1**

### **SECTION A : READING**

**20 Marks**

1. Read the passage given below and answer the questions that follow:

**12 marks**

1. While there is no denying that the world loves a winner, it is important that you recognize the signs of stress in your behaviour and be healthy enough to enjoy your success. Stress can strike anytime, in a fashion that may leave you unaware of its presence in your life. While a certain amount of pressure is necessary for performance, it is important to be able to recognise your individual limit. For instance, there are some individuals who accept competition in a healthy fashion. There are others who collapse into weeping wrecks before an exam or on comparing marks-sheets and finding that their friend has scored better.
2. Stress is a body reaction to any demands or changes in its internal and external environment. Whenever there is a change in the external environment such as temperature, pollutants, humidity and working conditions, it leads to stress. In these days of competition when a person makes up his mind to surpass what has been achieved by others, leading to an imbalance between demands and resources, it causes psycho-social stress. It is a part and parcel of everyday life.
3. Stress has a different meaning, depending on the stage of life you are in. The loss of a toy or a reprimand from the parents might create a stress shock in a child. An adolescent who fails an examination may feel as if everything has been lost and life has no further meaning. In an adult the loss of his or her

companion, job or professional failure may appear as if there is nothing more to be achieved.

4. Such signs appear in the attitude and behaviour of the individual, as muscle tension in various parts of the body, palpitation and high blood pressure, indigestion and hyper-acidity. Ultimately the result is self-destructive behaviour such as eating and drinking too much, smoking excessively, relying on tranquilisers. There are other signs of stress such as trembling, shaking, nervous blinking, dryness of throat and mouth and difficulty in swallowing.
  5. The professional under stress behaves as if he is a perfectionist. It leads to depression, lethargy and weakness. Periodic mood shifts also indicate the stress status of the students, executives and professionals.
  6. In a study sponsored by World Health Organization and carried out by Harvard School of Public Health, the global burden of diseases and injury indicated that stress diseases and accidents are going to be the major killers in 2020.
  7. The heart disease and depression - both stress diseases - are going to rank first and second in 2020. Road traffic accidents are going to be the third largest killers. These accidents are also an indicator of psycho-social stress in a fast moving society. Other stress diseases like ulcers, hypertension and sleeplessness have assumed epidemic proportions in modern societies.
  8. A person under stress reacts in different ways and the common ones are flight, fight and flee depending upon the nature of the stress and capabilities of the person. The three responses can be elegantly chosen to cope with the stress so that stress does not damage the system and become distress.
  9. When a stress crosses the limit, peculiar to an individual, it lowers his performance capacity. Frequent crossings of the limit may result in chronic fatigue in which a person feels lethargic, disinterested and is not easily motivated to achieve anything. This may make the person mentally undecided, confused and accident prone as well. Sudden exposure to un-nerving stress may also result in a loss of memory. Diet, massage, food supplements, herbal medicines, hobbies, relaxation techniques and dance movements are excellent stress busters.
- (a) (i) What is stress? What factors lead to stress? 2
- (ii) What are the signs by which a person can know that he is under stress? 2

- (iii) What are the different diseases a person gets due to stress? 2
- (iv) Give any two examples of stress busters. 1
- (v) How does a person react under stress? 2
- (b) Which words in the above passage mean the same as the following? 3
  - (i) fall down (para 1)
  - (ii) rebuke (para 3)
  - (iii) inactive (para 9)

2. Read the passage given below and answer the questions that follow:

**8 marks**

Research has shown that the human mind can process words at the rate of about 500 per minute, whereas a speaker speaks at the rate of about 150 words a minute. The difference between the two at 350 is quite large.

So a speaker must make every effort to retain the attention of the audience and the listener should also be careful not to let his mind wander. Good communication calls for good listening skills. A good speaker must necessarily be a good listener.

Listening starts with hearing but goes beyond. Hearing, in other words is necessary but is not a sufficient condition for listening. Listening involves hearing with attention. Listening is a process that calls for concentration. While, listening, one should also be observant. In other words, listening has to do with the ears, as well as with the eyes and the mind. Listening is to be understood as the total process that involves hearing with attention, being observant and making interpretations. Good communication is essentially an interactive process. It calls for participation and involvement. It is quite often a dialogue rather than a monologue. It is necessary to be interested and also show or make it abundantly clear that one is interested in knowing what the other person has to say.

Good listening is an art that can be cultivated. It relates to skills that can be developed. A good listener knows the art of getting much more than what the speaker is trying to convey. He knows how to prompt, persuade but not to cut off or interrupt what the other person has to say. At times the speaker may or may not be coherent, articulate and well organised in his thoughts and expressions. He may have it in his mind and yet he may fail to marshal the right words while communicating his thought. Nevertheless a good listener puts him at ease, helps him articulate and facilitates him

to get across the message that he wants to convey. For listening to be effective, it is also necessary that barriers to listening are removed. Such barriers can be both physical and psychological. Physical barriers generally relate to hindrances to proper hearing whereas psychological barriers are more fundamental and relate to the interpretation and evaluation of the speaker and the message.

- (a) On the basis of your reading of the above passage, make notes in points only, using abbreviations wherever necessary. Supply a suitable title. 5
- (b) Write a summary of the above passage in about 80 words. 3

**SECTION - B**  
**(Advanced Writing Skills)**

**35 Marks**

3. Your school has planned an excursion to Lonavala near Mumbai during the autumn holidays. Write a notice in not more than 50 words for your school notice board, giving detailed information and inviting the names of those who are desirous to join. Sign as Naresh/Namita, Head Boy/Head Girl, D.V. English School, Thane, Mumbai. **5 marks**

**OR**

C.P.R. Senior Secondary School, Meerut is looking for a receptionist for the school. Draft an advertisement in not more than 50 words to be published in classified columns of Hindustan Times. You are Romola Vij, Principal of the school.

4. Your school Commerce Association organised a seminar for class XII students of the schools of your zone on the topic, 'Rising prices create a crisis'. As Co-ordinator of the programme, write a report in 100-125 words for your school magazine. You are Piyush/Priya of ABC School, Agra. **10 marks**

**OR**

A new indoor gymnasium has recently been constructed and inaugurated at APJ International School at Goa. As special correspondent of 'The Hindu' draft a report in 100-125 words on the gymnasium and the inauguration ceremony.

5. You are Pritam/Priti, 27, W.E.A. Karol Bagh, Delhi. You have decided to shift your residence to Faridabad and hence decided to discontinue your membership of Brain Trust Library, Karol Bagh. Write a letter to the Librarian, requesting him to cancel your membership and refund your security deposit of Rs. five thousand explaining your inability to continue your membership. **10 marks**

**OR**

You are Anu/Arun, 13 W.E.A. Karol Bagh, New Delhi. You feel very strongly about the ill-treatment meted out to stray dogs at the hands of callous and indifferent people. Write a letter to the editor of a national daily giving your views on why some people behave in such a manner and how these dogs should be treated.

6. Spurt of violence previously unknown in Indian schools makes it incumbent on the educationists to introduce value education effectively in schools. Write an article in 150-200 words expressing your views on the need of value education. You are Anu/Arun.

**10 marks**

**OR**

Regular practice of yoga can help in maintaining good health and even in the prevention of so many ailments. Write a speech in 150-200 words to be delivered in the morning assembly on the usefulness of yoga.

**SECTION - C**  
**(Text Books)**

**45 Marks**

7. (a) Read the extract given below and answer the questions that follow:

**4 marks**

The stunted, unlucky heir

Of twisted bones, reciting a father's gnarled disease,

His lesson, from his desk. At back of the dim class

One unnoted, sweet and young. His eyes live in a dream,

Of squirrel's game, in tree room, other than this.

(i) Who is the 'unlucky heir' and what has he inherited?

2

(ii) What is the stunted boy reciting?

1

(iii) Who is sitting at the back of the dim class?

1

**OR**

For once on the face of the Earth

let's not speak in any language,

let's stop for one second,

and not move our arms so much.

- (i) Why does the poet want us to keep quiet? 2
- (ii) What does he want us to do for one second? 1
- (iii) What does he mean by 'not move our arms' ? 1
- (b) Answer any three of the following in 30-40 words each: **2 x 3 = 6 marks**
- (i) Why are the young trees described as 'sprinting' ?
- (ii) How is a thing of beauty a joy forever?
- (iii) Why didn't the 'polished traffic' stop at the roadside stand?
- (iv) Why did Aunt Jennifer choose to embroider tigers on the panel?
8. Answer the following in 30-40 words each: **2 x 5 = 10 marks**
- (a) What changes did the order from Berlin cause in the school?
- (b) Why was Douglas determined to get over his fear of water ?
- (c) How were Shukla and Gandhiji received in Rajendra Prasad's house?
- (d) How did the author discover who the English visitor to the Studios was?
- (e) What did the publisher think of 'The Name of the Rose' ?
9. Answer the following in 125-150 words: **10 marks**
- How are the attitudes of the ironmaster and his daughter different? Support your answer from the text.
- OR**
- Compare and contrast Sophie and Jansie highlighting their temperament and aspirations.
10. Answer the following in 125-150 words: **7 marks**
- How did the Tiger King stand in danger of losing his Kingdom? How was he able to avert the danger?
- OR**
- What are phytoplanktons ? How are they important to our eco-system ?

11. Answer the following in 30-40 words each:

**2 x 4 = 8 marks**

- (a) Did Hana think the Japanese tortured their prisoners of war ? Why?
- (b) How did the Wizard help Roger Skunk ?
- (c) How does Mr. Lamb keep himself busy when it is a bit cool?
- (d) Who was Carter? What did the Governor ask him to do ?

**QUESTION PAPER CODE 1/1**

**SECTION A : READING**

**20 Marks**

1. Read the passage given below and answer the questions that follow:

12 marks

- 1 While there is no denying that the world loves a winner, it is important that you recognise the signs of stress in your behaviour and be healthy enough to enjoy your success. Stress can strike anytime, in a fashion that may leave you unaware of its presence in your life. While a certain amount of pressure is necessary for performance, it is important to be able to recognise your individual limit. For instance, there are some individuals who accept competition in a healthy fashion. There are others who collapse into weeping wrecks before an exam or on comparing mark-sheets and finding that their friend has scored better.
- 2 Stress is a body reaction to any demands or changes in its internal and external environment. Whenever there is a change in the external environment such as temperature, pollutants, humidity and working conditions, it leads to stress. In these days of competition when a person makes up his mind to surpass what has been achieved by others, leading to an imbalance between demands and resources, it causes psycho-social stress. It is a part and parcel of everyday life.
- 3 Stress has a different meaning, depending on the stage of life you are in. The loss of a toy or a reprimand from the parents might create a stress shock in a child. An adolescent who fails an examination may feel as if everything has been lost and life has no further meaning. In an adult the loss of his or her companion, job or professional failure may appear as if there is nothing more to be achieved.
- 4 Such signs appear in the attitude and behaviour of the individual, as muscle tension in various parts of the body, palpitation and high blood pressure, indigestion and hyper-acidity. Ultimately the result is self-destructive behaviour

such as eating and drinking too much, smoking excessively, relying on tranquilisers. There are other signs of stress such as trembling, shaking, nervous blinking, dryness of throat and mouth and difficulty in swallowing.

- 5 The professional under stress behaves as if he is a perfectionist. It leads to depression, lethargy and weakness. Periodic mood shifts also indicate the stress status of the students, executives and professionals.
- 6 In a study sponsored by World Health Organisation and carried out by Harvard School of Public Health, the global burden of diseases and injury indicated that stress diseases and accidents are going to be the major killers in 2020.
- 7 The heart disease and depression - both stress diseases - are going to rank first and second in 2020. Road traffic accidents are going to be the third largest killers. These accidents are also an indicator of psycho-social stress in a fast-moving society. Other stress diseases like ulcers, hypertension and sleeplessness have assumed epidemic proportions in modern societies.
- 8 A person under stress reacts in different ways and the common ones are flight, fight and flee depending upon the nature of the stress and capabilities of the person. The three responses can be elegantly chosen to cope with the stress so that stress does not damage the system and become distress.
- 9 When a stress crosses the limit, peculiar to an individual, it lowers his performance capacity. Frequent crossings of the limit may result in chronic fatigue in which a person feels lethargic, disinterested and is not easily motivated to achieve anything. This may make the person mentally undecided, confused and accident prone as well. Sudden exposure to un-nerving stress may also result in a loss of memory. Diet, massage, food supplements, herbal medicines, hobbies, relaxation techniques and dance movements are excellent stress busters.
  - (a)
    - (i) What is stress? What factors lead to stress? 2
    - (ii) What are the signs by which a person can know that he is under stress? 2
    - (iii) What are the different diseases a person gets due to stress? 2
    - (iv) Give any two examples of stress busters. 1
    - (v) How does a person react under stress? 2



(b) Which words in the above passage mean the same as the following?

3

(i) fall down (para 1)

(ii) rebuke (para 3)

(iii) inactive (para 9)

2. Read the passage given below and answer the questions that follow:

8 marks

Research has shown that the human mind can process words at the rate of about 500 per minute, whereas a speaker speaks at the rate of about 150 words a minute. The difference between the two at 350 is quite large.

So a speaker must make every effort to retain the attention of the audience and the listener should also be careful not to let his mind wander. Good communication calls for good listening skills. A good speaker must necessarily be a good listener.

Listening starts with hearing but goes beyond. Hearing, in other words is necessary, but is not a sufficient condition for listening. Listening involves hearing with attention. Listening is a process that calls for concentration. While listening, one should also be observant. In other words, listening has to do with the ears, as well as with the eyes and the mind. Listening is to be understood as the total process that involves hearing with attention, being observant and making interpretations. Good communication is essentially an interactive process. It calls for participation and involvement: It is quite often a dialogue rather than a monologue. It is necessary to be interested and also show or make it abundantly clear that one is interested in knowing what the other person has to say.

Good listening is an art that can be cultivated. It relates to skills that can be developed. A good listener knows the art of getting much more than what the speaker is trying to convey. He knows how to prompt, persuade but not to cut off or interrupt what the other person has to say. At times the speaker may or may not be coherent, articulate and well-organised in his thoughts and expressions. He may have it in his mind and yet he may fail to marshal the right words while communicating his thought. Nevertheless a good listener puts him at ease, helps him articulate and facilitates him to get across the message that he wants to convey. For listening to be effective, it is also necessary that barriers to listening are removed. Such barriers can be both physical and psychological. Physical barriers generally relate to hindrances to proper hearing whereas psychological barriers are more fundamental and relate to the interpretation and evaluation of the speaker and the message.

- (a) On the basis of your reading of the above passage, make notes in points only, using abbreviations wherever necessary. Supply a suitable title. 5
- (b) Write a summary of the above passage in about 80 words. 3

**SECTION B :**  
**ADVANCED WRITING SKILLS**

**35 Marks**

3. You are Mohan / Mohini, General Manager of P.K. Industries, Hyderabad. You need an accountant for your company. Draft, in not more than 50 words, an advertisement to be published in 'The Hindu' in classified columns. 5 marks

**OR**

You lost your Titan wrist-watch in your school. Draft a notice, in not more than 50 words, to be placed on your school notice board. You are a student of Class XII of Rani Ahalya Devi Senior Secondary School, Gwalior. Sign as Rani / Ram.

4. Your school has recently arranged a musical night in the school auditorium. Write a report in 100 - 125 words on this programme, for your school magazine. You are Mahima / Mahesh, Cultural Secretary of Vasant Vihar Public School, Itarsi. Invent the details. 10 marks

**OR**

You witnessed a fire accident in a slum area near your colony on Saturday night. You were very much disturbed at the pathetic sight. Write a report in 100 - 125 words for your school magazine. You are Lakshmi / Lakshman, a student of P.D.K. International School, Madurai.

5. Write a letter to the Station Master, Anand, informing him about the loss of your suitcase which you realized only on alighting at Anand. You travelled by Navjivan Express from Chennai to Anand. You are Priya / Prasad of 12, Kasturi Bai Street, Chennai - 20. 10 marks

**OR**

As a parent, write a letter to the Principal, ABC School Delhi, requesting him/her to grant your ward Akhil/Asha Arora, permission to attend the school two hours late for a month as he/she has to attend the coaching classes arranged by Sports Authority of India, on being selected for participation in National Swimming Championship.

6. Dance, as shown in some reality shows on TV, seems to be a mix of gymnastics and P.T. exercises. Actually it is neither. India has a rich tradition of classical and folk dances. Write an article in 150 - 200 words on the need to have a reality show exclusively based on Indian classical dances. You are Anu/Arun. 10 marks

**OR**

You are Ajay/Anu, Head Boy/Girl of Kendriya Vidyalaya, Kanpur. You have seen some students of junior classes littering the school compound and verandahs with tiffin left-overs. It makes the school look unclean and untidy. Write a speech in 150 - 200 words to be delivered in the morning assembly, advising such students to keep the school neat and clean.

**SECTION C**  
**TEXT BOOKS**

**45 Marks**

7. (a) Read the extract given below and answer the questions that follow: 4 marks

The sadness that lurks near the open window there,  
That waits all day in almost open prayer  
For the squeal of brakes, the sound of a stopping car,  
Of all the thousand selfish cars that pass,  
Just one to inquire a farmer's prices are.

- (i) Which open window is referred to ? Why does sadness lurk there? 2  
(ii) What does the farmer pray for? 1  
(iii) Is the farmer's prayer ever granted? How do you know? 1

**OR**

Far far from gusty waves these children's faces.  
Like rootless weeds, the hair torn around their pallor:  
The tall girl with her weighed-down head. The paper-  
seeming boy, with rat's eyes.

- (i) What are the children compared to ? 1  
(ii) Why do you think the tall girl is sitting with a weighed down head? 1  
(iii) Give two phrases which tell us that the children are under-nourished. 2

- (b) Answer any three of the following in 30 - 40 words each: 2x3=6 marks
- (i) What were the poet's feelings at the airport? How did she hide them?
  - (ii) How can suspension of activities help?
  - (iii) Why is 'grandeur' associated with the 'mighty dead' ?
  - (iv) How do the words, 'denizens' and 'chivalric' add to our understanding of Aunt Jennifer's tigers?

8. Answer the following in 30 - 40 words each: 2x5=10 marks
- (a) How did M. Hamel say farewell to his students and the people of the town?
  - (b) Who was the owner of Ramsjo iron mills? Why did he visit the mills at night?
  - (c) Why did Douglas go to Lake Wentworth in New Hampshire? How did he make his terror flee?
  - (d) Why could the bangle-makers not organise themselves into a co-operative?
  - (e) Why did Sophie not want Jansie to know anything about her meeting with Danny Casey?

9. Answer the following in 125 - 150 words: 10 marks
- Give an account of Gandhiji's efforts to secure justice for the poor indigo sharecroppers of Champaran.

**OR**

Subbu was a troubleshooter. Do you agree with this statement? Give an account of Subbu's qualities of head and heart.

10. Answer the following in 125 - 150 words: 7 marks
- How was 'injured' McLeery able to befool the prison officers?

**OR**

What impression do you form about Dr. Sadao as a man and as a surgeon on your reading the chapter, 'The Enemy' ?

11. Answer the following in 30 - 40 words each:

2×4=8 marks

- (a) What did Charley learn about Sam from the stamp and coin store?
- (b) Why was the Maharaja so anxious to kill the hundredth tiger?
- (c) How does Jo want the story to end?
- (d) What peculiar things does Derry notice about the old man, Lamb?

## Marking Scheme — English Core

### *General Instructions :*

1. Evaluation is to be done as per instructions provided in the Marking Scheme Only.
2. The Marking Scheme provides suggested value points and not the complete answers.
3. If a question has parts, marks must be awarded on the right hand side for each part. Marks awarded to different parts of a question should then be totalled up, written and circled on the left-hand margin of the answers concerned.
4. If a question does not have any parts, marks for that question must be awarded on the left-hand margin of the answer.
5. Where marks are allotted separately for content and expression as per the Marking Scheme, they have to be reflected separately and then totalled up. This is mandatory.
6. A slash (/) in the Marking Scheme indicates alternative answers(s) to a question. If a student writes an answer which is not given in the Marking Scheme but which seems to be equally acceptable, marks must be awarded in consultation with the Head-Examiner.
7. If a child has attempted an extra-question, the answer deserving more marks should be retained and the other answer be scored out.
8. Q1 under Section A (Reading) and Q7(a) under Section C (Text Books) have been designed to test students' ability to comprehend the given passage. As such the examinees need not to be unnecessarily penalised for their language errors.
9. Where questions have been designed to test the writing skills of students, the expression (grammatical accuracy, appropriate use of words, style, spelling, organization and presentation of relevant matter in a coherent and logical way) assumes as much importance as the content.
10. Identify major mistakes and shortcomings before awarding marks.
11. Wherever the word limit is given, no marks be deducted for exceeding it. However, due credit should be given for precise answers.

12. If a student, in response to a short-answer-type question, writes a single word / phrase answer which constitutes the core of the answer, it must be accepted and awarded marks.
13. If a student literally lifts a portion of the given passage / extract from the question paper as an answer to a question, no mark(s) to be deducted on this count as long as it is relevant and indicative of the desired understanding on the part of the student [reference questions under Q1 and Q7(a)].
14. A full scale of marks - 0 to 100 - is to be used while awarding marks. In case of an answer book deserving 90 marks and above, marks be awarded only in consultation with the Head Examiner.
15. As per orders of the Hon'ble Supreme Court, the candidates would now be permitted to obtain photocopy of the answer book on request on payment of the prescribed fee. All examiners/head examiners are once again reminded that they must ensure that evaluation is carried out strictly as per value points for each answer as given in the Marking Scheme.

**[FOR THE HEAD EXAMINERS ONLY]**

1. Answer scripts must be given to the evaluators for evaluation only after the given Marking Scheme has been thoroughly discussed with them collectively or individually. No exceptions, please.
2. The Head Examiner is required to go through the first five evaluated answer scripts of each examiner scrupulously to ensure that the evaluator concerned has evaluated the answer scripts as per the instructions provided in the Marking Scheme.
3. The Head Examiner is expected to examine the answer containing the value points that has not been provided in the Marking Scheme but the evaluator finds it equally correct for the purpose of awarding marks and give his / her decision which will be binding on the evaluator.
4. It is the bounden duty of each and every Head Examiner to do the random checking along with the answer books which deserve 90 marks and above, as reported by individual evaluators. The final decision in this regard, however, will rest with the Head Examiner only.

**EXPECTED ANSWERS/VALUE POINTS**

**SECTION A: (READING)**

**20 Marks**

**1 COMPREHENSION PASSAGE**

(a) NOTE: No mark(s) should be deducted for mistakes in usage and grammar, spelling, or word limit. Full marks may be awarded if a student has been able to identify the core ideas. If a student literally lifts a portion of the given passage as an answer to a question, no mark(s) to be deducted for this as long as it is relevant.

- (i) – body reaction to any demand or changes in its internal and external environment 1 mark
- changes in external environment such as temperature, pollutants humidity and working conditions 1 mark
- imbalance between demands and resources
- unrealistic ambitions

(any 2)

- (ii) – muscle tension in various parts of the body / palpitation / high blood pressure / indigestion / hyper-acidity / lethargic / disinterested / not easily motivated / mentally undecided / confused / accident prone / trembling / shaking / nervous blinking / dryness of throat and mouth / difficulty in swallowing / chronic fatigue / lowers performance capacity / periodic mood shifts / self destructive behaviour such as eating and drinking too much, smoking / excessively, relying on tranquilisers 2 marks

(any two)

- (iii) – heart disease / depression / ulcers / hypertension / sleeplessness / high BP / indigestion / hyper-acidity / chronic fatigue! loss of memory 2 marks

(any two)

- (iv) – diet / massage / food supplements! herbal medicines / hobbies / relaxation techniques / dance movements 1 mark

(any two)



- (v) – reacts in different ways. common ones are flight, fight and flee depending on the nature of stress and capabilities of the person / a professional behaves as if he is a perfectionist / stress has a different meaning depending on the stage of life / self destructive behaviour such as eating and drinking too much, smoking excessively, relying on tranquilisers

2 marks

(any two)

- (b) (i) collapse 1 mark
- (ii) reprimand 1 mark
- (iii) lethargic 1 mark

## 2 Note

- **If a student has attempted only summary or only notes, due credit should be given.**
- **1 mark allotted for the title be given if a student has written the title either in Q2(a) or Q2(b)**
- **Content must be divided into headings and sub headings**

The notes provided below are only guidelines. Any other title, main points and sub-points may be accepted if they are indicative of the candidate's understanding of the given passage, and the notes include the main points, with suitable and recognizable abbreviations. Complete sentences not to be accepted as notes. (In such cases ½ –1 mark may be deducted from marks awarded to content)

Numbering of points may be indicated in different ways, as long as a consistent pattern is followed.

### (a) NOTE MAKING

Distribution of Marks

**Abbreviations** / Symbols (with/without key) – any four 1 mark

**Title** 1 mark

**Content** (minimum 3 headings and sub-headings, with proper indentation and notes) 3 mark

### **Suggested Notes**

**Title:** Good Communication Skills / Good Listening / Listening Skills / Art of Listening / Listening / Good Communication and Listening / any other relevant title

- 1 Research
  - 1.1 human mind processes 500 wpm
  - 1.2 speaker speaks 150 wpm
  - 1.3 difference between the 2
- 2 A Good Speaker / Good Communication / Listening
  - 2.1 must retain attention of audience
  - 2.2 stop not to let mind wander
  - 2.3 must be a good listener
- 3 Listening / Requirement of Listening / Listening Skills
  - 3.1 hearing with attention
  - 3.2 being observant
  - 3.3 making interpretations
  - 3.4 concentration
  - 3.5 participation
- 4 A Good Listener / Good Listening - an Art / Traits Of Good Listening
  - 4.1 gets much more from speaker
  - 4.2 knows how to prompt and persuade
  - 4.3 puts speaker at ease
  - 4.4 helps him articulate
  - 4.5 facilitates speaker to convey thoughts
- 5 Effective Listening / Barriers to Good Listening
  - 5.1 barriers - phy. / psychological
    - 5.1.1. physical-hindrance to hearing
    - 5.1.2. psychological-interpretations & evaluation

(b) **Summary**

The summary should include all the important points given in the notes.

**Content**

2 marks

**Expression**

1 mark

## SECTION B: ADVANCED WRITING SKILLS

**NOTE:** The objective of the section on Advanced Writing Skills is to test a candidate's writing ability. Hence, expression assumes as much importance as the content of the answer.

### 3 NOTICE

#### Format

1 mark

The format should include: NOTICE / TITLE, DATE, and WRITER'S NAME WITH DESIGNATION. The candidate should not be penalized if he has used capital letters for writing a notice within or without a box.

#### Content

2 marks

#### Expression

2 marks

#### Suggested value points

(EXCURSION TO LONAVALA)

- what (excursion to Lonavala)
- when ( autumn break / duration of trip /date) - mode of transport (optional)
- meant for which class / age group
- other details (cost of trip / accommodation)
- last date for submission of names
- whom to contact
- any other relevant details

**OR**

#### ADVERTISEMENT

#### Content

3 marks

#### Expression

2 marks

#### Suggested value points

(SITUATION VACANT - FOR A RECEPTIONIST)

- name of school
- name of vacant post
- qualifications required, skills, personality, age

- salary / gender (optional)
- minimum experience required
- remuneration
- last date of applying
- contact details
- any other relevant details

(Due credit should be given for economy of words used)

#### 4 **REPORT WRITING**

##### **Format**

1. title, reporter's name
2. place, date – (optional) 1 mark

##### **Content**

4 marks

##### **Expression**

- grammatical accuracy, appropriate words and spelling [2½]
- coherence and relevance of ideas and style [2½]      5 marks

##### **Suggested value points:**

(UNPRECEDENTED PRICE RISE/ RISING PRICES CREATE A CRISIS / any other suitable heading)

- what - seminar on the problems of price rise and ways of dealing with it
- when - day, date and time
- where - venue
- by whom (School Commerce Association)
- participants (class XII)
- panel of resource persons / speakers
- highlights of the lecture
- any other relevant details

**OR**

### **Suggested value points**

#### **(INAUGURATION OF GYMNASIUM)**

- what - a new indoor gymnasium constructed and inaugurated
- size of the gym / number and types of machines available / ambience / facilities available
- when (day, date, time of inauguration)
- where (APJ International School, Goa)
- chief guest / other guests / audience
- details of the inauguration programme
- any other relevant details

## **5 LETTER WRITING**

[Note: - No marks are to be awarded if only the format is given. Credit should be given for the candidate's creativity in presentation of ideas. Use of both the traditional and the new format is permitted. ]

### **Format**

2 marks

1. sender's address, 2. date, 3. receiver's address, 4. subject / heading, 5. salutation, 6. complimentary close.

### **Content**

4 marks

### **Expression**

- grammatical accuracy, appropriate words and spelling [2]
- coherence and relevance of ideas and style [2]

4 marks

#### **(CANCELLATION OF LIBRARY MEMBERSHIP)**

### **Suggested Value Points**

- purpose (cancellation of membership and refund of Rs.5000 security deposit)
- reason (shift of residence to Faridabad)
- mention membership number
- status of issued books (if any)

- request for cancellation of membership and refund of Rs. 5000 as security deposit
- any other relevant details

**OR**

(ILL TREATMENT OF STRAY DOGS)

**Suggested Value Points**

Introducing the problem

- inhuman treatment to stray dogs
- present condition in cities: a large number of stray dogs in streets! beaten and teased by adults and children alike / killed due to accidents / catch fatal diseases
- callous and indifferent attitude of people
- why people behave in this manner - insensitive, treat stray dogs as a menace, no love for stray dogs, out of fear or any other reason

Suggestions: sensitising people / creating awareness / urging humane treatment; role of municipal authorities; NGOs etc

- any other relevant details

**6 ARTICLE WRITING**

**Format:** (Title and writer's name) 1 mark

**Content** 4 marks

**Expression**

- grammatical accuracy, appropriate words and spelling [2½ ]
- coherence and relevance of ideas and style [2½] 5 marks

**Suggested Value Points**

(VALUE EDUCATION - A MUST IN SCHOOLS / any other suitable title)

- present condition in schools (increase in violence / lack of discipline)
- reasons: overexposure to media / lack of emotional support / overambitious nature / peer pressure / lack of deterrence / any other)
- consequences: (spoils school culture and environment / self destruction / harm to society and country)

- suggestions for improvement (morning assemblies ,inspiring talks, stories, interaction with parents and teachers, counselling etc.)
- any other relevant details

OR

**SPEECH**

**Content** 5 marks

**Expression**

- grammatical accuracy, appropriate words and spelling [2½ ]
- coherence and relevance of ideas and style [2½] 5 marks

**Suggested Value Points**

(USEFULNESS OF YOGA / any other suitable title)

- addressing the audience
- highlighting the problems (increase in health problems - physical, mental, emotional, psychological, etc)
- advantages of yoga (a way of life)
- increase in yoga centres today / its popularity :
- cures many ailments /works on body, mind and soul/no side effects / slow and steady process / gives long lasting results
- appropriate and relevant conclusion
- any other relevant details

**SECTION C: LITERATURE (TEXT BOOKS)**

**NOTE:** The objective of the section on literature is to test a candidate’s ability to understand and interpret the prescribed text through short and long answer type questions. Hence both content and expression in answers to the given questions deserve equal importance while awarding marks.

- 7 This question has been designed to test the students’ understanding of the text and their ability to interpret, evaluate and respond to the questions based on the given extract. In other words, it attempts to test their reading comprehension ONLY.

**Value points:**

- (a) (i) – the boy with twisted bones / the one with deformity / a boy sitting in the slum classroom / the stunted boy / the boy who inherited his father's gnarled disease 1 mark
- inherited twisted bones / deformity / gnarled disease 1 mark
- (ii) – his lesson / father's gnarled disease 1 mark
- (iii) – one unnoted / sweet and young / dreamer / one who dreams about a squirrel's game 1 mark

**OR**

- (i) – to take stock of our mindless activities / to be able to count to twelve / to do self-analysis / for mental relaxation / to ensure peace / to introspect / to save mankind from imminent doom 2 marks
- (ii) – keep quiet / not speak / not to move our arms so much / stop all activities / to do nothing - no speech, no activity 1 mark
- (iii) – no movement / no activity / not to harm others / no wars / no violence 1 mark
- (b) **Short answer type questions (Poetry) : any three**

Distribution of marks:

**Content:** 1 mark

**Expression** 1 mark

(deduct ½ mark for two or more grammatical/spelling mistakes)

**Value points:**

- (i) – trees appear to be running when seen from the moving car / symbolic of life / youth / energy / vigour / continuity of life 2 marks
- (ii) – its loveliness increases / is perennial / is constant / sustains human spirit in all ages & stages / never passes into nothingness / moves away the pall from our dark spirits / makes life worth living 2 marks
- (iii) – their mind set on their destination / are insensitive and indifferent / the road side stand does not matter to them / does not have anything of value for them 2 marks



- (iv) – wanted to project her wishes on the panel / to express her hidden desire / wanted to forget her meek, miserable life / wanted to be like the tigers - fearless, proud, unafraid, chivalrous / to escape from the harsh realities of her life 2 marks

**8 Short answer type questions (Prose)**

Distribution of marks:

**Content:** 1 mark

**Expression**

(deduct ½ mark for two or more grammatical/spelling mistakes) 1 mark

**Value points:**

- (a) – announcement that French would not be taught anymore / German would be taught by a new master 2 marks
- was their last French lesson
  - no bustle and commotion (quiet as a Sunday morning)
  - M. Hamel - patient, calm but inwardly emotional
  - students in their seats, sitting quietly
  - the teacher M. Hamel in special dress
  - sad villagers sitting on last benches like other students
  - School seemed strange and solemn on that day
  - The teacher explained everything very patiently

(any two)

- (b) – His fear of water ruined his fishing trips 2 marks
- deprived him of the joy of canoeing, boating and swimming

(anyone)

- (c) – allowed them to stay on the grounds 2 marks
- Rajendra Prasad was out of town
  - The servants knew Shukla

- They thought Gandhi was another peasant
- Gandhi not permitted to draw water from the well as servants not sure about his caste

(any two)

- (d) – went to British Council Library to get details of the short story contest organised by a British periodical 2 marks

- read editor's name and found it was the poet who had visited the studios

(any one)

- (e) – liked the novel but did not expect to sell more than 3,000 copies 2 marks

- novel dealt with mystery, medieval history, metaphysics and theology
- assumed that it was a difficult reading experience
- did not expect a good response in America as few people have seen a cathedral and have studied Latin .

(any two)

Q 9 & 10 [These questions have been set to test the students' understanding of the text and their ability to interpret, evaluate and respond to the issues raised therein. Hence no particular answer can be accepted as the only correct answer. All presentations may be accepted as equally correct provided they have been duly supported by the facts drawn from the text. The important thing is that the student should be able to justify his or her viewpoint.]

9 Distribution of marks:

**Content:** 5 mark

**Expression** 5 mark

- grammatical accuracy, appropriate words and spelling [2½]
- coherence and relevance of ideas and style [2½]

**Value points:**

**Ironmaster**

- impulsive. doubting, poor judge of character, loving father
- invites Peddler to his house, realises that he is no acquaintance, threatens to hand him over to the Sheriff, asks him to leave his house as fast as he can

- owner of Ramsjo Iron Mill / devoted to his work / greatest ambition is to ship out good iron to the market
- watches the work in his mill, both night and day / makes nightly rounds of inspection
- gives in to the request of his daughter to allow the peddler to be with them on the Christmas Eve (any two)

**Daughter**

- loving, caring, kind, thoughtful, generous, magnanimous, observant, insightful, true Christian spirit
- observant - notices that the peddler is afraid, concludes that either he has stolen something or he has escaped from jail
- better powers of persuasion - convinces the peddler to accompany her to the Manor house on the promise that he can leave as freely as he comes
- even after knowing the truth, argues with her father to be kind and generous and to allow the peddler to stay with them
- succeeds in transforming the peddler

(any two)

OR

**Sophie and Jansie are classmates and friends**

**Sophie**

- daydreamer / escapist / hero worshipper
- wants to have a boutique / to be an actress / a designer / or do something sophisticated
- shares her dreams only with her brother, considers Jansie as noseypicker (gossip monger)
- adores Danny Casey - football player and fantasizes meeting him
- any other point

(any two)

**Jansie**

- realistic and practical / worldly wise
- knows that they are poor and earmarked for biscuit factory
- warns Sophie against unrealistic and unachievable dreams
- takes interest in knowing about new things / different in thinking and temperament
- has no unrealistic dreams
- any other point

(any two)

10 Distribution of marks:

**Content**

4 marks

**Expression**

- grammatical accuracy, appropriate words and spelling [2½ ]
- coherence and relevance of ideas and style [2½]

5 marks

**Value points:**

- the Tiger King annoyed a high ranking British officer by refusing to allow him to kill tigers in his province
- did not even allow him to get himself photographed with the tiger killed by the king
- prevented a British officer from fulfilling his desire - so stood in danger of losing his kingdom

(anyone)

- averted the danger by sending a gift of fifty diamond rings (to choose one or two from) to the British officer's wife.

**OR**

- microscopic, single celled plants (grass) of the sea (1 mark)
- important to our ecosystem
- nourish and sustain the entire food chain of the Southern Ocean

- they use sun's energy to absorb carbon and synthesize organic compounds by photosynthesis
- they will be affected with ozone depletion
- the lives of all the marine animals and birds and global carbon cycle will be affected
- they carry a metaphor for existence - take care of small things and the big things will fall into place

(any two)

(3 marks)

11 Distribution of marks:

**Content:** 1 mark

**Expression** 1 mark

(deduct ½ mark for two or more grammatical/spelling mistakes)

**Value Points:**

(a) - Yes (½ mark) 2 marks

- had heard about stories of suffering of prisoners of war/ tortured body of the American POW confirmed her fears / remembered General Takima who beat his wife cruelly at home/ wondered if he could be so cruel to his wife, he would be more cruel to an enemy soldier (1½ marks)

(b) - removed his foul smell with the magic spell/ gave him the beautiful smell of roses / helped him in having many friends 2 marks

(c) - gets a ladder and a stick and pulls down the crab apples / makes jelly / enjoys the humming of bees in his garden / sits in the sun / reads books / makes toffee with honey 2 marks

(any two)

(d) - Detective Superintendent (½ mark) 2 marks

- asked him to take McLerry with him and follow Evans on McLerry's direction (1½ marks)

QUESTION PAPER CODE 1/1  
**EXPECTED ANSWERS/VALUE POINTS**  
**SECTION A: (READING) 20 Marks**

**1 COMPREHENSION PASSAGE**

(a) NOTE: No mark(s) should be deducted for mistakes in usage and grammar, spelling, or word limit. Full marks may be awarded if a student has been able to identify the core ideas. If a student literally lifts a portion of the given passage as an answer to a question, no mark(s) to be deducted for this as long as it is relevant.

- (i) – body reaction to any demand or changes in its internal and external environment 1 mark
- changes in external environment such as temperature, pollutants, humidity and working conditions 1 mark
- imbalance between demands and resources
- unrealistic ambitions
- (any 2)
- (ii) – muscle tension in various parts of the body / palpitation / high blood pressure / indigestion / hyper-acidity / lethargic / disinterested / not easily motivated / mentally undecided / confused / accident prone / trembling / shaking / nervous blinking / dryness of throat and mouth / difficulty in swallowing / chronic fatigue / lowers performance capacity / periodic mood shifts / self destructive behaviour such as eating and drinking too much, smoking excessively, relying on tranquilisers 2 marks
- (any two)
- (iii) – heart disease / depression / ulcers / hypertension / sleeplessness / high BP / indigestion / hyper-acidity / chronic fatigue / loss of memory 2 marks
- (any two)
- (iv) – diet / massage / food supplements / herbal medicines / hobbies / relaxation techniques / dance movements 1 mark
- (any two)

- (v) – reacts in different ways, common ones are flight, fight and flee depending on the nature of stress and capabilities of the person / a professional behaves as if he is a perfectionist / stress has a different meaning depending on the stage of life / self destructive behaviour such as eating and drinking too much, smoking excessively, relying on tranquilisers

2 marks

(any two)

- (b) (i) collapse 1 mark  
(ii) reprimand 1 mark  
(iii) lethargic 1 mark

## 2 Note

- **If a student has attempted only summary or only notes, due credit should be given.**
- **1 mark allotted for the title be given if a student has written the title either in Q2(a) or Q2(b)**
- **Content must be divided into headings and sub headings**

The notes provided below are only guidelines. Any other title, main points and sub-points may be accepted if they are indicative of the candidate's understanding of the given passage, and the notes include the main points, with suitable and recognizable abbreviations. Complete sentences not to be accepted as notes. (In such cases ½ –1 mark may be deducted from marks awarded to content)

Numbering of points may be indicated in different ways, as long as a consistent pattern is followed.

### (a) NOTE MAKING

Distribution of Marks

**Abbreviations / Symbols** (with /without key) – any four 1 mark

**Title** 1 mark

**Content** (minimum 3 headings and sub-headings, with proper indentation and notes) 3 marks

### **Suggested Notes**

**Title:** Good Communication Skills / Good Listening / Listening Skills / Art of

Listening / Listening / Good Communication and Listening / any other relevant title

- 1 Research
  - 1.1 human mind processes 500 wpm
  - 1.2 speaker speaks 150 wpm
  - 1.3 difference between the 2
- 2 A Good Speaker / Good Communication / Listening
  - 2.1 must retain attention of audience
  - 2.2 stop not to let mind wander
  - 2.3 must be a good listener
- 3 Listening / Requirement of Listening / Listening Skills
  - 3.1 hearing with attention
  - 3.2 being observant
  - 3.3 making interpretations
  - 3.4 concentration
  - 3.5 participation
- 4 A Good Listener / Good Listening - an Art / Traits Of Good Listening
  - 4.1 gets much more from speaker
  - 4.2 knows how to prompt and persuade
  - 4.3 puts speaker at ease
  - 4.4 helps him articulate
  - 4.5 facilitates speaker to convey thoughts
- 5 Effective Listening / Barriers to Good Listening
  - 5.1 barriers - phy. / psychological
  - 5.2 physical-hindrance to hearing
  - 5.3 psychological-interpretations & evaluation

(b) **Summary**

The summary should include all the important points given in the notes.

**Content**

2 marks

**Expression**

1 mark



## SECTION B: ADVANCED WRITING SKILLS

**NOTE:** The objective of the section on Advanced Writing Skills is to test a candidate's writing ability. Hence, expression assumes as much importance as the content of the answer.

### 3 ADVERTISEMENT

**Content** 3 marks

**Expression** 2 marks

#### **Suggested value points**

(SITUATION VACANT / WANTED / REQUIRED)

- post - Accountant
- name of company (employer)
- qualifications
- age
- mode of application
- last date of receipt of application
- gender / salary (optional)
- who to apply to
- any other relevant details

(Due credit should be given for economy of words used)

**OR**

### **NOTICE**

**Format** 1 mark

The format should include: NOTICE / TITLE, DATE, and WRITER'S NAME WITH DESIGNATION. The candidate should not be penalized if he has used capital letters for writing a notice within or without a box.

**Content** 2 marks

**Expression** 2 marks

### **Suggested value points**

(LOSS OF WRIST WATCH)

- lost a Titan Watch
- when
- where
- description - colour, strap, dial, ladies / gents (anyone)
- request to return with reward if any
- contact
- any other relevant details

## **4 REPORT WRITING**

### **Format**

1. title, reporter's name
2. place, date – (optional) 1 mark

**Content** 4 marks

### **Expression**

- grammatical accuracy, appropriate words and spelling [2½]
- coherence and relevance of ideas and style [2½] 5 marks

### **Suggested value points:**

(MUSICAL NIGHTI any other suitable heading)

- what
- when
- where - venue
- target audience (students / parents)
- highlights - performers / special guests
- audience response
- any other relevant details

OR

**Suggested value points**

(FIRE ACCIDENT / any other suitable heading)

- what
- when
- where
- the scene (billowing smoke, panic, wailing of victims, arrival of fire engine)
- suspected cause (how)
- loss / damage (life / property)
- visit of officials
- enquiry ordered
- rescue and relief (first aid etc / compensation)
- response of neighbourhood
- any other relevant details

(NOTE: first / third person account may be accepted)

**5 LETTER WRITING**

[Note: - No marks are to be awarded if only the format is given. Credit should be given for the candidate's creativity in presentation of ideas. Use of both the traditional and the new format is permitted. ]

**Format**

2 marks

1. sender's address, 2. date, 3. receiver's address, 4. subject / heading, 5. salutation, 6. complimentary close.

**Content**

4 marks

**Expression**

- grammatical accuracy, appropriate words and spelling [2]
- coherence and relevance of ideas and style [2]

4 marks

(LOSS OF SUITCASE)

**Suggested Value Points**

- details of train journey / compartment (coach no, seat no, date, time - optional)
- description of suitcase
- request for immediate action
- contact details
- any other relevant details

**OR**

(PERMISSION TO ATTEND SCHOOL LATE)

**Suggested Value Points**

- details of your ward (name / class / section)
- information about selection for National Swimming Championship
- reason - coaching by Sports Authority
- requesting permission for 2 hr late attendance for one month (specify time in the morning)
- any other relevant details

**6 ARTICLE WRITING**

**Format:** (Title and writer's name) 1 mark

**Content** 4 marks

**Expression**

- grammatical accuracy, appropriate words and spelling [2½ ]
- coherence and relevance of ideas and style [2½] 5 marks

**Suggested Value Points**

(NEED FOR INDIAN CLASSICAL DANCE BASED REALITY SHOWI any other suitable title)

Status of present reality shows

- mix of gymnastics and PT exercises

- do not represent Indian culture
- ape the west

(anyone)

Need for exclusive reality show to showcase Indian classical and folk dances.

- classical and folk dances represent India's cultural legacy
- can revive the national spirit since many old art forms are dying
- will reach a large target audience because of the viewership of reality shows

(anyone)

- any other relevant details

OR

**SPEECH**

**Content**

5 marks

**Expression**

- grammatical accuracy, appropriate words and spelling [2½ ]
- coherence and relevance of ideas and style [2½]

5 marks

**Suggested Value Points**

(LITTERING THE SCHOOL COMPOUND)

- addressing the audience
- stating the problem
- surroundings unclean, untidy and unhygienic

(anyone)

- importance and need to keep the premises clean
- students' responsibility
- use of dustbins
- ensure clean surroundings

(anyone)

- conclusion

## SECTION C: LITERATURE (TEXT BOOKS)

**NOTE:** The objective of the section on Literature is to test a candidate's ability to understand and interpret the prescribed text through short and long answer type questions. Hence both content and expression in answers to the given questions deserve equal importance while awarding marks.

- 7 This question has been designed to test the students' understanding of the text and their ability to interpret, evaluate and respond to the questions based on the given extract. In other words, it attempts to test their reading comprehension ONLY.

### Value points:

- |     |       |   |                                                                                                                                            |        |
|-----|-------|---|--------------------------------------------------------------------------------------------------------------------------------------------|--------|
| (a) | (i)   | – | of the roadside stand                                                                                                                      | 1 mark |
|     |       | – | no one stops there to buy their farm products                                                                                              | 1 mark |
|     | (ii)  | – | squeal of brakes / sound of a stopping car / wishing someone to stop, ask the price and buy their produce / to get some city money in hand | 1 mark |
|     | (iii) | – | no                                                                                                                                         | 1 mark |
|     |       | – | they wait all day in open prayer / cars stop for other reasons but not to buy                                                              | 1 mark |

OR

- |       |   |                                                                                                                 |         |
|-------|---|-----------------------------------------------------------------------------------------------------------------|---------|
| (i)   | – | rootless weeds                                                                                                  | 1 mark  |
| (ii)  | – | physically and mentally exhausted / malnourished / burdened by poverty / because of the misfortunes of her life | 1 mark  |
| (iii) | – | paper seeming / hair tom round their pallor / rootless weed / rat's eyes (any two)                              | 2 marks |

### (b) Short answer type questions (Poetry) : any three

Distribution of marks:

**Content:** 1 mark

**Expression** 1 mark

(deduct ½ mark for two or more grammatical/spelling mistakes)

**Value points:**

- (i) – fear of separation / worried about her ageing mother / fear of losing her mother / anxiety 2 marks
  - by smiling / saying 'see you soon amma' / a cheerful farewell
- (ii) – time to introspect / to assess our own actions/ avoid destruction of mankind / reflect 2 marks
- (iii) – the heroic and impressive deeds of the dead inspire us and leave a legacy / remind us of the power and courage of great people 2 marks
- (iv) – tigers / bold / fearless / brave / can help the woman in trouble 2 marks

8 **Short answer type questions (Prose)**

Distribution of marks:

**Content:** 1 mark

**Expression**

(deduct ½ mark for two or more grammatical/spelling mistakes) 1 mark

**Value points:**

- (a) – announced that it was the last French lesson / asked everybody to preserve their language since it is most beautiful and also key to their freedom / prison / wrote on the blackboard "Viva La France" / said - school is dismissed, you may go 2 marks
- (b) – the ironmaster / Mr Willmansson 2 marks
  - to inspect that the work was done well / to ensure the quality of the work / nightly rounds of inspection / routine inspection
- (c) – to swim on his own and test if the old terror of water had left him 2 marks
  - swam two miles across / swam all strokes / terror returned for a moment but he laughed at it / brushed aside the fear
- (d) – no leader among them 2 marks
  - scared of authorities
  - scared of being hauled up and beaten by the police
  - years of exploitation left them timid

- vicious circle of sahuikars, middlemen, politicians, policemen, keepers of law, bureaucrats

(any two)

- (e) – Jansie was noseiy / gossip monger 2 marks
- she feared Jansie might tell the whole neighbourhood
  - Sophie's fantasy would be exposed
  - Jansie could not keep any secret

(any two)

Q 9 & 10 [These questions have been set to test the students' understanding of the text and their ability to interpret, evaluate and respond to the issues raised therein. Hence no particular answer can be accepted as the only correct answer. All presentations may be accepted as equally correct provided they have been duly supported by the facts drawn from the text. The important thing is that the student should be able to justify his or her viewpoint.]

9 Distribution of marks:

**Content:** 5 marks

**Expression** 5 marks

- grammatical accuracy, appropriate words and spelling [2½]
- coherence and relevance of ideas and style [2½]

**Value points:**

- studied the problems and got the facts
- visited the Secretary of the British landlords' association
- met the British Official Commissioner of Tirhut Division
- consulted the lawyers and chided them for collecting fee from the sharecroppers
- disobeyed the court order and listened to the voice of conscience
- inspired the peasants to overcome fear and be self reliant
- was prepared to go to prison for the sake of peasants



- agreed to 25% refund to make the poor farmers realize their rights
- inspired the lawyers to go to jail with him
- four protracted interviews with the Lieutenant Governor
- ensured the triumph of civil disobedience

(any four)

**OR**

Subbu was a trouble shooter

- he was no 2 at Gemini Studio
- an amazing actor / poet – tailor made for films
- creative and came up with solutions for a problem
- gave direction and definition to Gemini Studio in its golden years
- charitable, improvident and welcoming in nature, hospitable
- cheerful at all times
- wrote novels and stories

(any four)

10 Distribution of marks:

**Content** 4 marks

**Expression**

- grammatical accuracy, appropriate words and spelling [2½ ]
- coherence and relevance of ideas and style [2½] 5 marks

**Value points:**

- injured McLeery was Evans himself
- Evans impersonated McLeery with all make-up
- didn't take an ambulance to avoid being taken to hospital
- found a German question paper to convince the Governor of Evans' plans
- managed to leave the premises with the Detective Superintendent, Carter

(any two)

**OR**

- obedient son / humane / kind / compassionate / patriotic / a caring husband / a good human being / rose above national prejudice (any two)
- duty conscious / professional / skilful (anyone)

11 Distribution of marks:

**Content:** 1 mark

**Expression** 1 mark

(deduct ½ mark for two or more grammatical/spelling mistakes)

**Value Points:**

- (a) - Sam had bought 800 dollars worth of old style currency 2 marks
- (b) - to prove the astrologer's prediction wrong - about him being killed by the hundredth tiger / to save himself from being killed 2 marks
- (c) - wants the wizard to hit the mommy back / wants the story to end on a happy note / wished that Roger Skunk continues with the smell of roses 2 marks
- (d) - that he leaves the gates always open / welcomes strangers / the way Derry was treated / received by Lamb / he spoke things that others never did / lives in a huge house and a garden without curtains 2 marks

# FUNCTIONAL ENGLISH

*Time allowed : 3 hours*

*Maximum marks : 100*

## **General Instructions:**

- (i) *This paper is divided into four Sections: A, B, C and D. All the sections are compulsory.*
- (ii) *Separate instructions are given with each section and question, wherever necessary. Read these instructions very carefully and follow them faithfully.*
- (iii) *Do not exceed the prescribed word limit while answering the questions.*

## **QUESTION PAPER CODE 212/1**

### **SECTION A : READING**

**(20 Marks)**

1. Read the passage given below and answer the questions that follow:

**12 marks**

- (1) It was the year 2003. As a part of my efforts to understand schools and children of all ages, I happened to visit a Bangalore school that had a pre-school section. I followed the standard strategy of being a "fly on the wall," observing, absorbing, and when the situation was conducive, asking questions to students, teachers and administrators there.
- (2) The four-year-old in the junior kindergarten class was smart and highly communicative. She was very forthcoming with her responses. I asked her what she liked and what she did not like in general. She loved her school, her teacher, her mother, and her grandmother. She did not like it when her elder brother fought with her. She also did not like it when her grandmother told her bed-time stories!
- (3) This was rather strange, since I had believed that most children liked stories told by the elders in the family. So I was wondering why she did not like her grandmother telling her bed-time stories. After some patient interaction, the little girl told us: "When she tells me the stories, I go to sleep. But she wakes me up and asks me - the moral of the story!" I was stunned by her unexpected explanation. What struck me personally was the girl's ability to explain her discomfort. I also began to think about several misconceptions that elders have about issues related to the next generations.

- (4) Such as that we believe the stories are told in order that children would understand the moral of the story. Or that they go to the school to learn. Or that employees go to office to work.
- (5) Is it correct to assume that children go to school only to learn? They could be going there because that is what is expected of them by their parents. Or because they like to be with their friends in school. Or for the one teacher who tells them nice stories. Or they like the playground and the sports facilities.
- (6) The children are not even at a stage to understand the "moral" of the story. They may understand it cumulatively through several stories - which would be sunk in several layers of their understanding, only to emerge later. Or their moral of the story would be different than what we understand it to be. What about the pure enjoyment of the story by itself? What about several other uses of the story - such as understanding the language, relating to the characters, imagining the ethos, the feelings, and so on ?
- (7) As in many spheres of life, one of the biggest challenges in the educational system is that we have a first generation of leaders and educators that decide the education policy, the second generation of teachers that are responsible for facilitating education for the children who belong to a third generation.
- (8) Understanding third-generation children is a complex process and needs special efforts on the part of all concerned, including parents.
- (9) The third-generation children are fearless, articulate, independent, rational (capable of a high degree of analysis on "what is right and wrong" for them), impatient, non-hierarchical, and have wider methods of accessing knowledge. This requires a radically different organization of schools and classrooms, including in terms of the seating arrangements, the teaching-learning process, methods and material, and the quality of interaction with the children. Parents and teachers must jointly understand that comparing situations with their own childhood and therefore expecting certain types of responses from the children, will not work.
- (10) Children and their future must be at the heart of any decisions about curriculum, classroom practices, examination system and school management system.
  - (a) On the basis of your understanding of the passage, answer the following in your own words:

- |                                                                                               |   |
|-----------------------------------------------------------------------------------------------|---|
| (i) Why did the little girl in the kindergarten not like the stories told by her grandmother? | 2 |
| (ii) What is the writer's opinion about children being told stories with morals?              | 2 |
| (iii) What according to the writer is the problem with the education system today?            | 2 |
| (iv) According to the writer what should be the focus of modern day school system?            | 2 |
| (b) Pick out words/phrases from the passage which are similar in meaning to the following:    | 4 |
| (i) watching without being noticed or observed (para-1)                                       |   |
| (ii) willing to co-operate (para-2)                                                           |   |
| (iii) a mistaken belief or a misunderstanding (para-3)                                        |   |
| (iv) a distinctive character, belief and culture of people (para-6)                           |   |

2. Read the given passage carefully and answer the question that follow:

**8 marks**

When was the last time you laughed really hard - a hearty, side splitting belly laugh that suddenly grabbed you and sent you reeling out of control?

Modern science is beginning to confirm that this kind of laughter is not only enjoyable but also health promoting. Laughter is an invigorating tonic that heightens and brightens the mood, gently releasing us from tensions and social constraints.

If you hate to do a regular workout, laughter may be the exercise programme you've been looking for! Laughter is called "inner jogging". A robust laugh gives the muscles of your face, shoulders, diaphragm and abdomen a good workout. Heart rate and blood pressure temporarily rise, breathing becomes faster and deeper and oxygen surges through your bloodstream. Sometimes your muscles go limp and your blood pressure temporarily may fall, leaving you in a mellow euphoria. A good laugh can burn up as many calories per hour as brisk walking.

Sadly, our culture seems to inhibit humour. We learn to associate growing up with "getting serious" and being serious is somehow associated with being solemn and humourless. Sometimes we repress our good humour, because we are afraid that others will think we are frivolous or foolish.

But you need to repair your sense of humour. Expose yourself to humour and seek out things that make you laugh. Having a good sense of humour doesn't mean you have to have a store of jokes or tell them perfectly. Do not worry about how well you are telling it.

Focus on yourself rather than others. If you can allow yourself the inevitable mistakes then you can laugh at yourself. Those who can laugh at themselves have a much stronger sense of self worth than those who can't. A stressful situation can sometimes be transformed into a bit of fun if you can see the humour in it. Make sure that people around you are fun to be with. Certain people make you feel relaxed and happy. Spend more time with people who boost your mood. Research has shown that just changing your facial muscles can set off different physiological changes. It can also trigger different thoughts that affect moods of sadness, happiness and anger. And if you can't smile, fake it.

Not all humour is positive and healthy. Watch out for scorn, sarcasm, ridicule and contempt and inappropriate humour. And don't joke about people's names. They have to live with them. It is important to be sensitive.

Humour can be a powerful medicine and laughter can be contagious. And the only side effect is pleasure.

- (a) Make notes on the passage given above in any format using recognizable abbreviations. Give a suitable title to the passage. **5 marks**
- (b) Write a summary based on the notes you have made in about 80 words. **3 marks**

### **SECTION-B (Writing)**

**25 Marks**

3. Ratna's 3 month old pet Alsatian, Caesar has been missing for 2 days from her house in 76, Sainik Farms, Dehradun. Draft an advertisement in 50-80 words to be put in the classified columns of a newspaper giving all relevant details. **5 marks**

**OR**

Fatima is a student of St. Thomas School, Ghaziabad. Her school has recently added a gymnasium with the latest equipments. She is asked by her teacher to write a factual description of the gymnasium for the school prospectus. Write the description in 50-80 words.

4. Mrs Sen is the Warden of the school hostel of St. Marks School Ludhiana, Punjab. The linen, towels, blankets, mattresses and pillows need to be replaced as most of these items are worn out or torn. Write a letter to Sleepwell Stores, 34, M.G Road Ludhiana ordering the above mentioned items and requesting them to send the items at the earliest before the school reopens after the summer vacation. (80-100 words) **10 marks**

**OR**

You are Rini / Rishi Singh and want to change your job. You saw the following advertisement in the classified columns of Times Today and decide to apply for the job. Write an application and send it along with your biodata to the Director, HR. Media Communications, Block B 4, Ring Road, Noida.

**Media Communications**

A creative, innovative ad agency, having a strong presence in media and communications, urgently requires- *Marketing Executive*,

- Minimum Qualifications –BA/BSc/BCom
- Communication skills-English & Hindi
- Computer literate.
- Apply within 7 days to-Media Communications;  
Block B4, Ring Road, NOIDA

5. Jagpreet/Jassi attended a seminar on the occasion of the International Day on Drug Abuse and Illicit Trafficking and was appalled to hear about this increasing menace and its detrimental effect on society. He/she jotted down some points which he/she decides to use while talking about drug abuse in the school assembly. Using these inputs write a speech in about 200 words that he/she could deliver during the school assembly. **10 marks**

- *90 million drug users in the world -1 million heroin addicts in India officially, 5 million unofficially.*
- *affected group - earlier high income group; today all sections of society*
- *increase in crimes - eve teasing, violent clashes at home; thefts etc;*
- *damage to moral, physical, psychological, intellectual growth-loss of human potential.*

**OR**

You are Irfan/Shehnaz studying in Class XII. You came across the following piece in the Education Times and decide to write an article for your school magazine expressing your views on the subject. Write the article in about 200 words.

***Beating the Pressure***

*Coping with stress is not so easy, especially when you are a student. Today's youngsters are a stressed lot. Be it studies, peer pressure, parental demands or societal expectations-they are pressurized from all sides. But youngsters must learn to manage their stress. Plan, learn from examples, communicate and manage your stress-----*

**SECTION-C (Grammar)**

**20 Marks**

6. Re-arrange the following sentences sequentially to make complete sense: **5 marks**
- (a) Finally action will be taken against offenders.
  - (b) The Ghaziabad Police have launched a helpline for women with cellular operations.
  - (c) The phones will be attended to by female Sub Inspectors selected for their sensitivity.
  - (d) This helpline was first launched by the Meerut Police Zone Inspector General.
  - (e) A reward of Rs. 1000 will be offered to anyone for information that will curb eve teasing.
7. You are Rohit/Rama, a member of the Social Service Wing of the school. You have been asked to have a talk with a Traffic Constable about his life and experiences. One exchange has been done for you as an example. Write 5 more exchanges that took place between you two. Use the input given below to construct the dialogue. **5 marks**

*Reasons for joining the service, hours of duty, traffic-rule offenders, handling road rage, family life.*

Rohit/Rama : Sir, I see you at this traffic crossing every day. I would really like to know something about your life.

Traffic Constable: Sure. What would you like to know?



8. The following passage has ten errors. Identify the error in each line and write them along with the corrections as shown in the example: **5 marks**

A herd of over 20 elephants stray dangerously close stray-strayed

- (1) to the railway track and the highways near a forest
- (2) area in West Bengal upon Sunday morning. The area
- (3) between two forests was a elephant corridor and the
- (4) herd is trapped between the track and the national
- (5) highway. The elephant remained stranded there for
- (6) the day but were driven back to the forest on the
- (7) evening. Forest Department official immediately
- (8) alerted the Railway authorities of the herd and
- (9) trains passing in the stretch were asked to slow
- (10) down. The officials also asks for help from the district

Police as large crowds gathered to watch the elephants.

9. Lifeline Hospital has recently opened a branch in Gurgaon. You are Robin/Rebecca who has joined the Customer Care Cell of the hospital. You have been asked to construct a set of 10 questions to be used in a feedback form for people using the hospital. Using the given input make the questionnaire. **5 marks**

*Location, number of wards, cleanliness, specialty wards, nursing care, doctors, cost of treatment, concessions for the economically challenged, cafeteria/canteen, facilities for organ transplant*

#### **SECTION-D (Literature)**

**35 Marks**

10. Choose anyone of the extracts given below and answer the questions that follow: **7 marks**

These boys with old, scared faces, learning to walk

They'll soon forget their haunted night

- (a) Who are the 'boys' referred to in these lines? 1
- (b) Why do they have scared faces? 1

- (c) What is paradoxical about the second line? 2
- (d) Why do the 'boys' have haunted nights? 2
- (e) Why do they have to learn to walk again? 1

**OR**

But her hands are a wet eagle's  
two black crinkled feet  
one talon crippled in a garden  
trap set for a mouse.

- (a) Name the poem and the poet. 1
- (b) Who is the person referred to as 'her' ? 1
- (c) Pick out the literary device used in the first line and explain it. 2
- (d) How has the person been crippled ? 2
- (e) What are the other changes that have happened to her? 1

11. Answer any two of the following in about 50 words each: **4×2 = 8 marks**

- (a) Why do the bees get fooled during the autumn season? Describe their condition during this season.
- (b) Pick out any two examples used in the poem, 'Curtain' to emphasize the theme of separation.
- (c) How does the narrator convey the trauma experienced by the soldiers in the poem, 'Survivors' ?

12. Answer the following in 80-100 words: **5 marks**

Where had Sergeant Morris found the monkey's paw? How many people had used it before the Whites? Why was Morris reluctant to hand over the paw to the Whites?

**OR**

Who was Queen Mother? What was strange about her relationship with Alexander?

13. Answer any two of the following in about 50 words each: **4×2 = 8**

- (a) Do you think Roux from the lesson, 'Judgement of Paris' was benefitted from his meeting with the comedians in the cafe? Give reasons for your answer.

- (b) Despite her house being requisitioned by the Government, Mrs. Malik was not too upset. Give reasons.
- (c) What were the reasons that made Asoka such a popular king with his subjects?

14. Answer the following in 100-125 words:

**7 marks**

Compare and contrast the two old men- the beggar from the story, 'What's Your Dream' ? and Iona Potapov from the story, 'Grief' .

**OR**

A newspaper critic present at Lisa's performance after Doronin's death is taken in by the sheer brilliance of her performance. He writes a short report describing the events that have led to the transformation of Lisa from a small time actress to a 'real' one. Write the report.

**QUESTION PAPER CODE 212**

**SECTION A : READING**

**(20 Marks)**

1. Read the passage given below and answer the questions that follow:

**12 marks**

- 1 Life begins at 40. Mine certainly did. Our son wanted to study at a good university abroad. In the early 1950s, if you had a dream, it remained unfulfilled unless you could afford it. Taking a loan was unthinkable. That was only for life and death matters. We advised our son to keep studying and graduate well from school.
- 2 For the first time in my life I thought of taking up a job. At 40 ? No degrees, no business experience. Not very promising. Besides, I would hate to be cooped up in an office from nine to five. What would I like to do ? I liked meeting people. That suggested travel, tourism, hotels. Although we had lived in Calcutta for years, I had never really seen the city. For the next four Sundays, my husband drove me to all the places in the Guide Book. My inspection tours showed there was good scope for an entrepreneur in city tourism. Why not become a tourist guide? I was sure I could do a much better job. Then the 'buts' set in. What will people say? Why is Silloo roaming around in taxis with strange men? Are the Mehta's so hard up ? Could I take it ?
- 3 It wouldn't require much capital. The only investment was myself. The more knowledge I acquired about the country, the better I would be at my job. I

definitely liked the idea because it gave me freedom to be myself. One morning, dressed elegantly, I went to a major travel agent's office. Assuming me to be a customer, I was shown to the Manager's desk. I told him what I had discovered and suggested he engage me as a guide for his tourists. Mr. Roper was astonished but receptive. He said, "Mrs. Mehta, you are the answer to our prayers. Many a time we have to pull out the office staff because we have no one to accompany our VIP tourists." Thus began Mrs. Mehta's Guide Service.

- 4 Next day I called some of my friends to coffee. I selected four ladies. All were educated, intelligent and comfortable in any society. They were bored with their lives and as I expected, ready to try something new. I warned them that they would earn peanuts but learn a great deal. I prepared a slim guide book about India. My guides should know something about India's history, geography, governance, economy, population, religions, etc ...
- 5 We spend a large part of the time driving around and talking to the tourists. By the end of the tour we have usually established a good rapport. When I read some of the letters tourists have written to me, I feel a glow in my heart even now. I don't remember their faces but they must have been nice people to take time from their busy lives to say 'thank you' to a guide so far away. Here are some of the nicest letters. "You are the best guide I've ever had in all my lengthy travels." "You contributed more to my understanding of India than several dozens of other people." "The very delicious tea in your home and the stimulating conversation is one of the highlights of our trip." What more can one want?
- 6 Slowly, the business grew. Suddenly, everyone wanted to be one of Mrs. Mehta's guides. Those who had taken a dim view of my career choice began calling me up !
- 7 In the meantime, my son got a scholarship to the university.
  - (a) On the basis of your understanding of the passage, answer the following in your own words:
    - (i) Why was the narrator unable to fulfill her son's dream of studying abroad? 2
    - (ii) What are the factors that dissuaded the narrator from taking up a job as a tourist guide? 2

- (iii) What did the narrator require to start her new business? 2
- (iv) Was the narrator a successful businesswoman? Give reasons for your answer. 2
- (b) Pick out words/phrases from the passage which are similar in meaning to the following: 4
  - (i) someone who starts a business (para 2)
  - (ii) willing to listen or consider suggestions (para 3)
  - (iii) understanding and respecting one another (para 5)
  - (iv) making one feel active/inspiring (para 5)

2. Read the given passage carefully and answer the questions that follow: 8 marks

The key finding in a recent study that even top schools in major cities in India suffer from the entrenched tendency to impart rote learning may have some shock value to those who believe that private educational institutions place greater emphasis on quality and holistic education. However, for those closely observing the school education scenario, it is a re-affirmation of a bitter truth: schools in our country are, by and large, quite far from seeing education as a process of learning with understanding, acquiring knowledge through self-discovery and conceptualisation; rather, education remains a mere transmission of information in a rigid classroom atmosphere, where the emphasis is on memorisation and the objective is to rush through a pre-determined syllabus and prepare children for examinations. While on the scholastic side the WIPRO-Educational Initiatives 'Quality Education Study', which covered 89 schools, shows fall in learning standards among students in classes 4, 6 and 8 over the last five years, it also flags a disturbing deficit of social sensitivity on the part of a sizable section of students. Responses to some questions relating to the education of girls and attitudes towards immigrants, the disabled, and HIV-positive patients, indicated biases that could, over time, grow into prejudices. Exploring the mind of the young at a formative stage in this way, which some might consider methodologically challengeable, is a particularly valuable part of this study. It will be a serious mistake to ignore the broad trend that indicates misconceptions of early years being carried on to a higher age and the possibility of these children imbibing biases they see in their family atmosphere or social milieu.

Over the years, there have been some serious efforts to put in place a national curriculum framework. For instance, the Yash Pal Committee's progressive report

of 1993, *Learning without Burden*, demonstrated how the curriculum load was a burden on the child and highlighted the defects of the examination system. The National Curriculum Framework 2005 was a game attempt to provide a vision of education as a pursuit of both quality and equity. Yet, despite increasing awareness that learning is not mere information accumulation and that teaching ought to be recast into a facilitation of children's discovery of their own potential and understanding, the emphasis in practice continues to be on textbooks and exams. Conceptual understanding is not encouraged anywhere near enough, and sport, art, debate, and cultural activity are kept at the distant periphery. It is time not merely for fostering greater awareness about the need for holistic education but also to chalk out more imaginative pedagogic means to make education an inclusive and quality-centric epistemic process.

- (a) Make notes on the passage given above in any format using recognizable abbreviations. Give a suitable title to the passage. 5
- (b) Write a summary based on the notes you have made in about 80 words. 3

### SECTION B - WRITING

25 Marks

3. Cardio-vascular diseases cause 29% deaths every year making it the world's no. 1 killer. A few lifestyle changes can bring down the number. On the occasion of 'World Heart Day', Puneet has decided to design a poster to create an awareness in his school about the dangers of modern lifestyle and its effect on the human heart. Draft the poster in 50 to 80 words. 5 marks

OR

The recent earthquake in Sikkim has left thousands affected. Goonj, an NGO, has decided to help the victims by collecting woollens and foodgrains to help them survive the coming winter season. Poonam Singla, the Social Service Wing Co-ordinator of Harsha Public School, has been asked to draft a notice for her school notice board asking students to contribute generously. Draft the notice in 50 to 80 words.

4. Radha read the following news item and decided to write a letter to the editor of a national daily, highlighting the problem of repeated terrorist attacks and what she feels should be done to combat this menace. Write the letter in 125 - 150 words. 10 marks

**Delhi Blast: Yet another wake-up call?**

Delhi Speaks:

- Blaming each other no use - all agencies sit together; take stock of situation
- Attitude of common man one of indifference; as long as families safe - it's business as usual
- terrorism complex phenomena; only talking about war on terror won't work; one has to execute and deliver.

**OR**

Jose/Josephine has recently bought a laptop from Jumbo Electronics, 2/4 Main Street, Bengaluru. However it has begun to malfunction within a week of buying it. Write a letter in 125 - 150 words to the manager of the shop listing out the problems you are facing, asking him to rectify them.

5. You are Rana/Rajni studying in Class XII. You came across the following piece in a magazine and decided to write an article for your school magazine expressing your views on the subject. Write the article in about 200 words.

10 marks

***Beating the Pressure***

*Coping with stress is not so easy, especially when you are a student. Today's youngsters are a stressed lot. Be it studies, peer pressure, parental demands or societal expectations –they are pressurized from all sides. But youngsters must learn to cope. Plan, learn from examples, communicate and manage their stress...*

**OR**

The following statistics ring a warning bell about the alarming rise in pollution in the metropolitan cities of India. Taking help from the given data, Raghu/Rati writes a speech to be delivered on World Environment Day in the morning assembly of his/her school on the need to be more aware of the dangers we are causing to our environment and suggesting solutions for the same. Write the speech in about 200 words.

**Huge price to pay for so called progress !!!**

- *67% air pollution due to vehicular pollution 25% industries / thermal power plants*

- *Air pollution kills one every hour*
- *7500 premature deaths due to air pollution*
- *1 out of 10 -15 people likely to get lung cancer*
- *1 out of every 10 school kids suffers from asthma*

### SECTION C - GRAMMAR

20 Marks

6. Re-arrange the following sentences sequentially to make complete sense: 5 marks
- This decay results in sharp pain experienced on consumption of cold and hot foods.
  - Pain can also occur due to several reasons, like receding gums, incorrect brushing techniques, etc.
  - The pain arises when the innermost layer of our tooth is exposed.
  - Moreover, surveys conducted have shown that 40% of the country's population suffers from tooth decay.
  - People often do not take tooth decay seriously or are unaware about the possible consequences.
7. Yash / Yana attended a mountaineering camp during the summer break. Later she was interviewed by a reporter of the journal "TREKKER" on her experiences at the camp. Write 5 more exchanges that took place between them. Use the input given below to construct the dialogue. One has been done as an example. 5 marks
- Desire to trek; Group of young people accompanying; facilities; challenges; feelings after the adventure.
- Reporter* : How long did it take you to climb the peak?
- Yash/Yana* : It took us a fortnight.
8. The following passage has ten errors. Identify the error in each line and write them along with the corrections as shown in the example: 5 marks
- Skipping breakfast, especially amidst primary and eg amidst - among
- secondary school children, affect mental performance
  - in a classroom, thus lending weight to the old adage that



- (iii) a healthy breakfast gets you of to a good start for the day.
  - (iv) New research show that eating breakfast benefits the memory.
  - (v) It provides essential nutrient and energy. Children who skip breakfast
  - (vi) does not make up for nutrient and energy deficits later in the day
  - (vii) and tend to perform poorly in tests of cognition than those
  - (viii) who had their breakfasts. Study conducted by some doctor's
  - (ix) in U.K. found that a high blood glucose level after having
  - (x) breakfast is one of the key reason for improvement in performance.
9. Fitness First, a wellness centre, has opened in your locality. Ravi / Radhika is doing a summer job there during his/her vacations. He/She has been asked to construct a set of 10 questions that they are to use as a feedback form for customers. Use the input given below to make the questionnaire. The first question has been done as an example. 5 marks

Location, capacity, decor, cleanliness and hygiene, variety of equipment, quality of trainers, adequate number of trainers, service, time spent with customers.

*Have you visited the wellness centre before?*

**SECTION D - LITERATURE**

35 Marks

10. Choose anyone of the following extracts and answer the questions that follow: 7 marks
- And a pain still throbs in the old, old scars  
 And they pulse again with a keener sting –  
 I know why he beats his wing!
- (a) Name the poem and the poet. 1
  - (b) Why has the word 'old' been repeated twice in the first line? 2
  - (c) Why is the bird bruised and full of scars? 2
  - (d) How does the bird try to cope with its pain? 2

**OR**

A poem should be equal to  
Not true  
For all the history of grief  
An empty doorway and a maple leaf  
For love  
The leaning grasses and two lights above the sea  
A poem should not mean but be

- (a) Name the poem and the poet. 1
- (b) What are the symbols used in the above lines? What do they convey? 2
- (c) Explain the line - 'A poem should not mean but be' ? 2
- (d) According to the poet, what is the purpose of using symbols in a poem? 2
11. Answer any two of the following in about 50 words each: 2×4=8
- (a) Why does the narrator of the poem, 'Ode to Autumn' describe autumn as a season of 'mists and mellow fruitfulness' ?
- (b) What does the narrator of the poem, 'Curtain' wish to convey by referring to Hamlet?
- (c) Describe the feelings of the son depicted in the poem, 'Of Mothers, Among Other Things'. What does he wish to express by saying 'my tongue licks bark'?

12. Answer anyone of the following in 80-100 words: 5
- What are the elements used by the writer of the play, 'The Monkey's Paw' to create a feeling of horror?

**OR**

Who was Perdicas ? Why was he missing from the camp when Alexander decided to move towards India ? Was he a part of the army when they moved camp and started on their journey to India? Give reasons for your answer.

13. Answer any two of the following in about 50 words each: 2×4=8
- (a) How is a child's world different from that of an adult's as discussed in the essay, 'Hum of Insects' ?

- (b) Why did Iona have to unburden himself to his horse? What does this tell you about the people around him?
- (c) Give examples from the story, 'The Actress' that reveal Lisa to be a sensitive person.

14. Answer anyone of the following in 100 - 125 words:

7

"Room 10' × 8' highlights the deteriorating family values in society."

Explain this statement with reference to the story.

**OR**

Compare and contrast the characters of Robichon and Quinquart. Do you agree with the judgement of Paris? Give reasons for your answer.

## Marking Scheme — Functional English

### *General Instructions :*

1. The Marking Scheme carries only suggested value points for the answers. These are only guidelines and do not constitute the complete answer. The students can have their own expression and if the expression is correct, the marks should be awarded accordingly.
2. Answer scripts should not be given to the evaluators for evaluation until and unless the given Marking Scheme has been thoroughly discussed with them in a group or individually on the first day of evaluation.
3. The Head Examiner must go through the first five answer scripts evaluated by each evaluator to ensure that the evaluation has been carried out as per the Marking Scheme. The remaining answer scripts meant for evaluation shall be given only after ensuring that there is no significant variation in the marking of individual evaluators.
4. Evaluation is to be done as per instructions provided in the Marking Scheme. It should not be done according to one's own interpretation or any other consideration. However, the Marking Scheme carries only suggested value points and does not constitute the complete answer.
5. If a question has parts, please award marks on the right hand side for each part. Marks awarded for different parts of the question should then be totalled up and written in the left hand margin and circled.
6. If a question does not have any parts, marks must be awarded in the left-hand margin.
7. Where marks are allotted separately for content and expression in the Marking Scheme they have to be reflected separately and then totalled. This is a mandatory requirement.
8. A slash (/) in the Marking Scheme indicates alternative answers. If a student writes an answer which is not given in the Marking Scheme but which is equally acceptable, marks should be awarded only in consultation with the Head Examiner.
9. If a candidate has attempted an extra question, answer of the question deserving more marks should be retained and the other answer be scored out.
10. If a student writes a single word in response to a short answer type question and it constitutes the core of the answer it should be accepted and awarded full marks.
11. If a student literally lifts a portion of the given passage as an answer to a question no marks should be deducted for this so long as it is relevant and indicative of the desired understanding on the part of the student especially in Q.1 (Section A) and Q.10 (Section D).

12. Some of the questions may relate to Higher Order Thinking Skills. These questions are to be evaluated carefully and student's understanding/analytical ability may be judged.
13. Wherever the word limit is given, no marks are to be deducted for exceeding the word limit.
14. As per orders of the Honourable Supreme Court, the candidates would now be permitted to obtain photocopy of the Answer Book on request on payment of the prescribed fee. All Examiners/Head Examiners are once again reminded that they must ensure that evaluation is carried out strictly as per value points for each answer as given in the Marking Scheme.
15. All Examiners/Head Examiners are instructed that while evaluating the answer scripts, if the answer is found to be totally incorrect, the (x) should be marked on the incorrect answer and awarded '0' mark.
16. A full scale of marks - 0 to 100 is to be used. In case of an answer book deserving 95 marks and above, marks be awarded in consultation with the Head Examiner only.

### QUESTION PAPER CODE 212/1

### EXPECTED ANSWERS/VALUE POINTS

**SECTION A: (READING) 20 Marks**

**Q1 READING LEARNING FROM FAILURE TOTAL MARKS: 12**

Under Section A, Reading (Q1), questions have been designed to test a student's understanding of the passage and his/her ability to interpret, evaluate and respond to the given passage. As such, content assumes more importance than expression in the answers to these questions. Please do not hesitate to award full marks if the answer deserves it.

**Objective :** To identify and understand main parts of the text.

**Marking :** As marked in the question paper

**Note :** No penalty for spelling and grammar errors.

Accept any other word equivalent in meaning to the answers given below.

**Suggested Answers:**

a)

- i. fell asleep 1  
woken up from sleep, asked to tell the moral of the story 1
- ii. children not at a stage to understand morals / understanding stories takes time / child's understanding of morals varies from that of adults (any two) 1+1
- iii. 1st generation leaders and educators decision makers, 2nd generation teachers facilitators and 3rd generation learners; understanding 3rd generation learners a complex process/ today's learners have wider exposure 1+1
- iv. focus –  
on children and their future when decisions are made on curriculum, exams and school management system/  
teaching process/  
quality of interaction/  
radically different organization of schools and classrooms in terms of seating arrangements/  
the teaching learning process/ methods and materials  
(any 2) 1+1

**b. VOCABULARY**

**4 marks**

**Objective :** To deduce the meanings of unfamiliar lexical items.

**Marking :** 1 mark each (4 marks)

- Answers :**
- (i) fly on the wall
  - (ii) forthcoming \ communicative
  - (iii) misconception
  - (iv) ethos

**Q 2. Note Making and Summarizing**

**Total Marks: 8**

**Objective :** To develop the skill of taking down notes

To develop the extracted ideas into a sustained piece of writing.

<b>Marking : Note making</b>	<b>5 marks</b>
Heading	1 mark
Abbreviations / symbols (with or without key) (minimum four)	1 mark
Content (minimum three sub headings)	3 marks

**Important instructions:**

The notes provided below are only guidelines. Any other title, main points and sub-points should be accepted if they are indicative of students' understanding of the given passage and the notes include the main points with suitable and recognizable abbreviations.

**Complete sentences should not be accepted as notes. Half a mark should be deducted from the total if the student writes complete sentences.**

**Numbering of points can be indicated in different ways and these should be accepted as long as it follows a consistent pattern.**

**Q 2.a) Note Making**

**Note: If a student has attempted only the summary or only the notes, due credit should be given.**

**Suggested Notes**

**Title : Laughter-The Best Medicine \ Inner Jogging**

- I. Benefits
  - a. healthy & enjoyable
  - b. brightens mood
  - c. relaxes from tension & social constraints
- II. An exercise
  - a. considered inner jogging
  - b. workout for mus. of face/shoulder/etc;
  - c. O<sub>2</sub> surges thro. blood stream
  - d. burns calories

- III. Culture and humour
  - a. growing up means getting serious
  - b. being serious means being humourless
  - c. humour thus repressed
  - d. consider being humorous as foolish
- IV. Need to improve sense of humour
  - a. expose oneself to humour
  - b. learn to laugh at self
  - c. be with fun loving ppl
  - d. see humour in stressful situations
- V. Not all humour positive and healthy
  - a. scorn/sarcasm/ridicule inappropriate
  - b. joking about names is insensitive

**Key to Abbreviations used:**

<b>&amp;</b>	–	<b>and</b>
<b>O2</b>	–	<b>oxygen</b>
<b>thro.</b>	–	<b>through</b>
<b>mus.</b>	–	<b>muscles</b>
<b>ppl.</b>	–	<b>people</b>
<b>/</b>	–	<b>or</b>

- Note: 1. Any abbreviations made by the students should be accepted.
2. No student to be penalized if they have not given a key to abbreviations separately.

**Q2b) Summary**

- Objective:** 1) To expand notes ( headings and sub-headings ) into a summary
- 2) To test ability of extraction



<b>Marking:</b> Content	2 marks
Expression	1 mark

**SECTION B WRITING TOTAL - 25 MARKS**

In Section B, where questions have been designed to test the writing skills of the students, expression (grammatical accuracy, appropriate vocabulary and style, spellings, organization and presentation of relevant matter in a coherent and logical way) is important.

**Q.3. OPTION-1 ADVERTISEMENT-LOST DOG TOTAL – 5 MARKS**

**Objective:** To design a classified advertisement in an appropriate style

<b>Marking :</b> Format	1 mark
Title - Lost and Found \ Missing	
Content	2 marks

**Suggested Value Points**

- breed; gender; colour; age; size; identifying features;
  - lost - when and where;
  - contact person - name and address/ telephone number
  - mention of reward (if any)

Expression	2 marks
------------	---------

**Option-2 FACTUAL DESCRIPTION - GYMNASIUM TOTAL – 5 MARKS**

**Objective :** To use a style appropriate to writing a factual description

<b>Marking :</b>	5 marks
Format (title)	½ mark
Content	2½ marks

**Suggested value points:**

- location
- Size
- description of equipments

- people using it
- benefits

Expression

2 marks

- accuracy
- fluency

1 mark

1 mark

**Q.4. Option -1**

**LETTER ORDERING GOODS**

**TOTAL -10 MARKS**

**Objectives:** To use an appropriate style to write a formal letter.

To plan, organize and present ideas coherently

**Marking:** Format

2 marks

1. sender's address, 2. date
3. address of the addressee
4. salutation, 5. subject
6. complimentary close
7. sender's signature/name

Content

4 marks

**Suggested value points**

- placing order for linen/towels/etc
- details - quantity /colour /size/brand etc
- discount (if any)
- mode of payment
- any other relevant details

Expression

4marks

- grammatical accuracy, appropriate words and spellings 2 marks
- coherence and relevance of ideas and style 2 marks

**Note: Credit to be given even if all the points in the question are not mentioned due to the word limit constraint in the question.**



### **Suggested Value Points**

- refer to the given input
- reasons for increase in menace
- effect on individual and society
- measures to fight it at both social and personal levels

Any other relevant points

Expression 5 marks

- grammatical accuracy, appropriate words and spellings (2½)
- coherence and relevance of ideas and style (2½)

### **Option – 2**

#### **ARTICLE – STRESS**

**Objective:** To write in a style appropriate to the given situation

To plan, organize and present ideas coherently

To analyze given input and arrive at conclusions

Marking: Format 1 mark

(heading and writer's name)

Content 4 marks

#### **Suggested value points**

- reasons for stress
- effects of stress
- how to deal with it

Any other relevant point

Expression 5 marks

- grammatical accuracy, appropriate words and spellings (2½)
- coherence and relevance of ideas and style (2½)

**SECTION C****(GRAMMAR)****20 MARKS**

In Section C, care should be taken not to award marks to any inaccurate answer carrying errors in grammar and punctuation.

**Q6. REARRANGING****TOTAL: 5 MARKS**

**Objectives:** To be able to present ideas in grammatically logical sequence

5 marks

**Marking:** 1 mark for every correct answer

**Answer** (b, d, c, e, a) or (b, d, c, a, e)

- b. The Ghaziabad Police have launched a helpline for women with cellular operations.
- d. This help-line was first launched by the Meerut Police Zone Inspector General.
- c. The phones will be attended to by female Sub Inspectors selected for their sensitivity.
- e. A reward of Rs.1 000 will be offered to anyone for information that will curb eve teasing
- a. Finally action will be taken against offenders.

**Or**

- b. The Ghaziabad Police have launched a helpline for women with cellular operations.
- d. This help-line was first launched by the Meerut Police Zone Inspector General.
- c. The phones will be attended to by female Sub Inspectors selected for their sensitivity.
- d. Finally action will be taken against offenders.
- e. A reward of Rs.1000 will be offered to anyone for information that will curb eve teasing

**Q7. DIALOGUE WRITING****TOTAL-5 MARKS**

**Objectives:** To extend the given input into a meaningful dialogue

**Marking:** 1 mark each for every correct exchange provided it is accurately and appropriately expressed. No marks should be awarded if there is

any inaccuracy. This includes inaccuracies in grammar, spelling or punctuation. 5 marks

### Sample Answers

Rohit/Rama: Sir, why did you join the police force?

Policeman: It was my childhood dream to become a policeman.

Rohit/Rama: What are your duty hours?

Policeman: I am on duty for ten hours a day.

Rohit/Rama: How do you handle the traffic - rule offenders?

Policeman: The offenders are fined Rs.100.

Rohit/Rama: How do you deal with incidents of road rage?

Policeman: I deal with them very strictly.

Rohit/Rama: Sir, does your work affect your family life?

Policeman: Of course, it does, however, I have learnt to cope with it.

### Q.8. EDITING

**TOTAL: 5 MARKS**

**Objectives:** To use grammatical items appropriately

**Marking:** ½ mark each

If the candidate copies the sentence and replaces the incorrect word with the correct answer, marks should be awarded. However, no marks are to be deducted if the candidate has given only the correct words.

	<b>Incorrect</b>		<b>Correct</b>
1.	highways	–	highway
2.	upon	–	on
3.	a	–	an
4.	is	–	was
5.	elephant	–	elephants
6.	on	–	in

- |     |          |   |           |
|-----|----------|---|-----------|
| 7.  | official | – | officials |
| 8.  | of       | – | about     |
| 9.  | in       | – | through   |
| 10. | asks     | – | asked     |

**Q9. FRAMING QUESTIONS**

**TOTAL-5 MARKS**

**Objectives:** To understand the context and frame relevant and appropriate questions.

**Marking:** ½ mark each for every accurate question framed

**Note:** No marks are to be awarded if there is any inaccuracy. The ten questions should cover at least two of the areas specified for the feedback form in the given input. Any other suitable questions may be acceptable. Marks should be awarded even if the child answers in the questionnaire format.

**Sample Answers:**

1. Do you think the hospital is centrally located?
2. Are there adequate numbers of wards in the hospital?
3. Is the cleanliness of the hospital satisfactory?
4. Are the speciality wards well equipped?
5. Is the nursing care adequate?
6. Are the doctors a committed lot?
7. Is the cost of treatment reasonable?
8. Does the hospital give concession to the economically challenged people?
9. Does the hospital have a canteen?
10. Is the hospital equipped for organ transplants?

**SECTION D:**

**LITERATURE**

**TOTAL -35 MARKS**

**Q10. REFERENCE TO CONTEXT**

**TOTAL- 7 MARKS**

Under Section D (Q10), questions have been designed to test a student’s understanding of the passage and his/her ability to interpret, evaluate and respond to the given passage. As such, content assumes more importance than expression in

the answers to these questions. Please do not hesitate to award full marks if the answer deserves it especially in the long answers.

**Objective:** To test students' comprehension of poetry- local, global, interpretative, inferential and evaluative

**Marking:** 7 marks

**Answers:**

**OPTION (1) SURVIVORS**

- a. soldiers who have survived the war/combatants/soldiers/survivors (any 1) 1
- b. because of the physical/mental trauma faced at the warfront /horrors of war/tiredness/exhaustion/shock and strain/victims of neurasthesia (any 2) 1
- c. – that the non-combatants feel that the combatants will forget their haunted nights and trauma and return to the war front  
– but in reality they are like helpless children; suffering / pride shattered 2
- d. – reminded of the scenes of horror witnessed at the battle ground  
– guilty at not being able to avenge the deaths of their comrades and their helplessness 2
- e. injuries on the battle field have crippled them / trying to cope with life after war 1

**OPTION (2) Of Mothers, Among Other Things**

- a. Of Mothers, Among Other Things ½  
A.K. Ramanujan ½
- b. mother 1
- c. hands are a wet eagle's–metaphor 1  
mother's hands compared to the eagle's two black crinkled feet (talons) 1
- d. finger caught in a garden trap 1  
while trying to catch a mouse 1



- e. become thinner; emaciated; feather of a onetime wing; dark and roughened skin; bent body  
(any two) ½ + ½

**Q11. POETRY (Any two)**

**TOTAL 4×2=8 MARKS**

**Objectives:** To test the students' comprehension of poetry – local and global

**Marking:** Content: 3 marks

Expression: 1 mark

- a. They are fooled because there is an abundance of later flowers  
They believe warm days will continue for ever  
They are satiated with nectar / over brimming of clammy cells
- b. goodbye/  
fingers loosen from warm interchange/  
division piles emphasis like bullets/  
the wave is broken/  
no touch now/  
distance out measures time engulfs identity/ quiet disaster/  
two Hamlets/  
white murder of one kiss/  
shrunk senses  
two worlds apart/  
one dark air separate and strange  
**(any two)**
- c. through the mention of the various sufferings experienced by the soldiers  
like- haunted nights, cowed subjection, their dreams drip with murder,  
learning to walk again, shattered pride, scared faces, eyes filled with  
hatred- broken and mad; stammering and disconnected talk;  
neurasthesia;  
any other relevant answer  
**(any four)**

**Q12. PLAY****TOTAL-5 MARKS**

**Objectives:** To test the students' ability to comprehend plays, understand character etc.

**Marking: Content:** 3 marks

**Expression:** 2 marks

**OPTION (1) THE MONKEY'S PAW****Suggested Answers:**

- He had got the paw from a fakir
- had been used by 2 people before the Whites
- because the first person who had used the paw had wished for death and Morris had also faced trouble; according to him paw brought bad luck-so reluctant to give it to anyone

**OR****OPTION (2) AN ADVENTURE STORY****Suggested Answer :**

- Queen Mother, mother of Darius, King of Persia, Alexander's enemy, also his prisoner
- though a prisoner was respected and loved by Alexander-treated her like his mother- wanted her approval and blessings before leaving for India.
- kneels down and thanks Queen Mother profoundly for breaking her vow of silence
- calls her mother

**Q13. FICTION (Any two)****TOTAL 4X2=8 MARKS**

**Objective:** To test student's ability to comprehend, interpret and evaluate prose texts

**Marking: Content** - 3 marks

**Expression** - 1 mark

- a. was helped by Robichon who masqueraded as Roux and gave his first speech at Appeville Sous Bois; earned double the money; free publicity for subsequent lectures; got rid of tensions and stress associated with his first public appearance on stage / debut postponed.

- b. firstly acquired by government / no headache of private tenants/ rent directly and regularly credited to bank / also transferred from Delhi. **(any 2)**
- c. Asoka-father figure, practised whatever he preached; built roads, hospitals other facilities for the subjects; appointed Censors of Piety and Almoners; kept strict watch on officers; engaged in the spread of Law of Piety; worked towards the progress, welfare and happiness of people; ensuring justice for all especially the old, the homeless and those with large families; practising high moral standards personally **(any 2)**

**Q14. LONG ANSWERS - FICTION**

**Total 7 marks**

**Objectives:** To test students' ability to comprehend prose texts globally, interpret and evaluate them.

**Marking:** Content - 4 marks  
Expression - 3 marks

**Option -1 COMPARISON OF BEGGAR & IONA**

**Note:** Marks should be awarded for the students' creativity

**Suggested Value Points:**

Similarity both old, lonely, poor, frail, wanted to pour out their heart

Dissimilarity Iona- depressed, introvert, difficulty in expressing himself, overwhelmed by circumstances, grief, had a family

beggar- extrovert, happy-go-lucky, garrulous, friendly, wise, at peace with himself, in rags, spoke English, had everything but lost it

**Option-2 ACTRESS**

**Suggested Value Points**

- brilliant performance of Lisa,
- brought dialogues to life
- experiences at warfront
- meeting Doronin-love of her life-subsequent death
- pain and suffering -matured her as an actress

**Note: No marks to be deducted for format**

**QUESTION PAPER CODE 212**  
**EXPECTED ANSWERS/VALUE POINTS**

**SECTION A**

**READING**

**20 MARKS**

**Q1. READING**

**TOTAL MARKS: 12**

Under Section A, Reading (Q1), questions have been designed to test a student's understanding of the passage and his/her ability to interpret, evaluate and respond to the given passage. As such, content assumes more importance than expression in the answers to these questions. Please do not hesitate to award full marks if the answer deserves it.

**Objective :** To identify and understand the main parts of the text.

**Marking :** As marked in the question paper. No penalty for spelling and grammar.

Accept any other answer equivalent in meaning to the answers given below.

**Answers : (a)**

- |      |                                                                                                                                      |         |
|------|--------------------------------------------------------------------------------------------------------------------------------------|---------|
| i.   | couldn't afford it                                                                                                                   | 1 mark  |
|      | taking loan unthinkable/loans meant only for serious issues                                                                          | 1 mark  |
| ii.  | fear of what people would say                                                                                                        | 1 mark  |
|      | assumed they were in a financial crisis/narrator moving around with unknown people (anyone)                                          | 1 mark  |
| iii. | investing herself/ knowledge of the country/less capital / identifying people who would like to act as guides and help her (any two) | 2 marks |
| iv.  | yes                                                                                                                                  | 1 mark  |
|      | evident from the letters of appreciation that she received/ many people wanted to join her company                                   | 1 mark  |

**b. VOCABULARY**

**Objective :** To deduce the meanings of unfamiliar lexical items.

**Marking :** 1 mark each (4 marks)

- Answers :**
- i. entrepreneur
  - ii. receptive
  - ii. rapport
  - iv. stimulating

**Q 2. Note making and Summarizing**

**Total Marks: 8**

**Objective :** To develop the skill of taking down notes

To develop the extracted ideas into a sustained piece of writing.

<b>Marking : Note making</b>	5 marks
Heading	1 mark
Abbreviations / Symbols (with or without key) (minimum four)	1 mark
Content (minimum three sub headings)	3 marks

**Important instructions:**

The notes provided below are only guidelines. Any other title, main points and sub points should be accepted if they are indicative of the students' understanding of the given passage and the notes include the main points with suitable and recognizable abbreviations.

**Complete sentences should not be accepted as notes. Half a mark should be deducted from the total if the student writes complete sentences.**

**Numbering of points can be indicated in different ways and these should be accepted as long as it follows a consistent pattern.**

**Q 2.a Note making**

**Note: If the student has attempted only the summary or only the notes, due credit should be given.**

**Suggested Notes**

**Title : NEED FOR HOLISTIC EDUCATION**

**OR**

### **Any other suitable title**

- I. School edn scenario today.
  1. No emphasis on quality & holistic edn
  2. Edn - mere tranformaton of infn.
    - i. rushing through syllabus
    - ii. rigid classrooms
    - iii. emphasis on rote lrng.
    - iv. preparing for exams
    - v. practised even in top private schools
- II. Research results
  1. fall in lrng. standards
  2. lack of social sensitivity
  3. bias against immigrants, disabled, edn. of girls
  4. misconceptions in formative years dangerous
    - i. impacts attitudes in adult life.
- III. Some recommendations
  1. Yashpal Committee report 1993
    - i.. curriculum a burden
    - ii. defective exam system
  2. NCF 2005 - vision
    - i. edn - a pursuit of quality and equity
  3. need for holistic education
    - i. creating imaginative pedagogy
    - ii. make edn inclusive and quality centric
- IV. Ground reality
  1. continuing dependence on textbooks and exams

2. conceptual understanding not encouraged
3. cultural activities secondary

**Key:**

1. edn. – education
2. thru – through
3. infn. – information
4. &. – and
5. lrng. – learning
6. NCF – National Curriculum Framework

- Note:**
1. Any other suitable abbreviations made by the students may be accepted.
  2. No penalty if a key to the abbreviations is not given.

**Q2. b. SUMMARY**

- Objective:**
- 1) To expand notes ( headings and sub-headings ) into a summary
  - 2) To test the ability of extraction

<b>Marking:</b> Content	2 marks
Expression	1 mark

**Note:** Considering the numerous facts mentioned in the notes, due consideration should be given to the students if they do not cover all the points in the summary which is expected to be concise. The summary should cover the essential details only.

**SECTION B**

**(WRITING)**

**TOTAL - 25 MARKS**

In Section B, where questions have been designed to test the writing skills of the students, expression (grammatical accuracy, appropriate vocabulary and style, spellings, organization and presentation of relevant matter in a coherent and logical way) is important.

**Q.3. OPTION 1**

**POSTER - HEALTHY LIFESTYLE**

**TOTAL – 5 MARKS**

**Objective:** To write in an appropriate style of a poster (blurbs, bullets, different font size etc. maybe considered)

<b>Marking :</b> Content	3 marks
--------------------------	---------

### **Suggested Value Points**

- heading / caption
- theme/ purpose
- catchy slogans
- dangers of modern lifestyle
- effect on human heart
- name of the issuing authority (optional)
- any other relevant points

Expression 2 marks

- coherence and relevance of ideas and style
- Due credit should be given for creativity and economy of words

### **OPTION 2                      NOTICE - DONATION                      TOTAL – 5 MARKS**

**Objective :** To write in an appropriate style of a notice

**Marking :** Format 1 mark

Notice/name of the institution, title, date and writer's name with the designation

The candidate should not be penalized if he has used block letters with or without a box.

Content 2 marks

### **Suggested Value Points**

- state the purpose - to collect donation
- time, date, venue for collection
- any other relevant information

Expression 2 marks

- coherence and relevance of ideas, accuracy and style



**Q.4. Option -1****LETTER TO THE EDITOR****TOTAL -10 MARKS****Objectives:** To use an appropriate style to write a formal letter.

To plan, organize and present ideas coherently

**Marking:** Format

2 marks

1. sender's address
2. date
3. address of the addressee
4. salutation
5. subject
6. complimentary close
7. sender's signature/name

Content

4 marks

**Suggested value points**

- use points given in the input - terrorism complex phenomenon
- take responsibility for the problems
- not depend on government for solutions
- proactive citizens/ sensitive to others
- suggest measures to tackle the issue.

Expression

4 marks

- grammatical accuracy, appropriate words and spellings 2marks
- coherence and relevance of ideas and style 2 marks

**Option -2****LETTER OF COMPLAINT****TOTAL -10 MARKS****Objectives:** To use an appropriate style to write a formal letter.

To plan, organize and present ideas coherently

**Marking:** Format

2 marks

1. sender's address
2. date

3. address of the addressee
4. salutation
5. subject
6. complimentary close
7. sender's signature/name

Content 4 marks

**Suggested value points**

- reference to date of purchase
- details of defect
- problems caused
- mention of warranty/guarantee period
- asking for replacement/repair

Expression 4 marks

- grammatical accuracy, appropriate words and spellings (2)
- coherence and relevance of ideas and style (2)

**Q.5. Option -1 ARTICLE - BEATING THE PRESSURE 10 MARKS**

**Objective:** To write in a style appropriate to the given situation.

To plan, organize and present ideas coherently.

To use given input and arrive at conclusions.

**Marking:** Format 1 mark

(heading and writer's name)

Content 4 marks

**Suggested value points**

- reasons for stress
- effect! result of stress
- dealing with stress/ solutions
- other relevant points

**Expression** 5 marks

- grammatical accuracy, appropriate words and spellings (2½)
- Coherence and relevance of ideas and style (2½)

**Option – 2**

**SPEECH – POLLUTION**

**TOTAL – 10 MARKS**

**Objectives:** To write in a style appropriate to the given situation.

To plan, organize and present ideas coherently.

**Marking:** Format 1 mark

(to include greeting and thanking the gathering)

Content 4 marks

**Suggested Value Points**

- refer to given data/input
- reasons for pollution
- measures to control pollution
- other relevant points

**Expression** 5 marks

- grammatical accuracy, appropriate words and spellings (2½)
- coherence and relevance of ideas and style (2½)

**SECTION C**

**(GRAMMAR)**

**20 MARKS**

In Section C, care should be taken not to award marks to any inaccurate answer carrying errors in grammar and punctuation.

**Q6. REARRANGING**

**TOTAL: 5 MARKS**

**Objective:** To read and arrange sentences in a sequential order 5 marks

**Marking:** 1 mark for every correct answer

**Answer**

**(v, i, iii, ii, iv) or (v, iv, i, iii, ii)**

- v. People often do not take tooth decay seriously or are aware about the possible consequences.
- i. This decay results in sharp pain experienced on consumption of cold and hot foods.
- iii. The pain arises when the innermost layer of our tooth is exposed.
- ii. Pain can also occur due to several reasons, like receding gums, incorrect brushing techniques etc.
- iv. Moreover, surveys conducted have shown that 40% of the country's population suffers from tooth decay,.

**Or**

- v. People often do not take tooth decay seriously or are aware about the possible consequences.
- iv. Moreover, surveys conducted have shown that 40% of the country's population suffers from tooth decay.
- i. This decay results in sharp pain experienced on consumption of cold and hot foods.
- iii. The pain arises when the innermost layer of our tooth is exposed.
- ii. Pain can also occur due to several reasons, like receding gums, incorrect brushing techniques etc.

**Q7. DIALOGUE WRITING**

**TOTAL-5 MARKS**

**Objective:** To extend the given input into a meaningful dialogue.

**Marking:** ½ mark each for every correct dialogue provided it is accurately and appropriately expressed. No marks should be awarded if there is any inaccuracy. This includes inaccuracies in grammar, spelling or punctuation. 5 marks

**Sample Answers:**

- a. Reporter: What motivated you to go on a trek?  
Yash/Yana: I enjoy trekking.

- b. Reporter: How many people were there in your group?  
Yash/Yana: We were ten in our group.
- c. Reporter: Were you satisfied with the facilities provided?  
Yash/Yana: They were good.
- d. Reporter: Was the trek challenging?  
Yash/Yana: Yes, that's what made it interesting.
- e. Reporter: How do you feel after the adventure?  
Yash/Yana: I feel really great.

**(Any other suitable exchange may be accepted)**

**Q.8. EDITING**

**TOTAL: 5 MARKS**

**Objective:** To use grammatical items appropriately

**Marking:** ½ mark each

If the candidate copies the sentence and replaces the incorrect word with the correct answer marks should be awarded. If only the correct words are given marks should be awarded.

	<b>Incorrect</b>		<b>Correct</b>
i.	affect	-	affects
ii.	a	-	the
iii.	of	-	off
iv.	show	-	shows
v.	nutrient	-	nutrients
vi.	does	-	do
vii.	than	-	over
viii.	had	-	have
	study	-	studies
	doctor's	-	doctors
ix.		-	no error
x.	reason	-	reasons

**Note: Line viii has 3 options as indicated above. Line ix has no error. ½ mark to be awarded irrespective of whether a student has made the correction or not.**

**Q9. FRAMING QUESTIONS****TOTAL-5 MARKS****Objectives:** To understand the context and frame relevant and appropriate questions.**Marking:** ½ mark each for every accurate question framed**Note:** No marks to be awarded if there is any inaccuracy. The ten questions should cover at least any of the two areas specified in the given input.**Suggested Answers:**

1. Is the wellness centre centrally located?
2. How large is the centre?
3. Do you like the decor of the centre?
4. Are you satisfied with the cleanliness and hygiene of the centre?
5. Is the equipment adequate and well maintained?
6. Are you happy with the quality of the trainers?
7. Are there adequate number of trainers?
8. Are the trainers courteous and helpful?
9. Are you satisfied with the service?
10. Do the trainers spend adequate time with the customers?

**SECTION D:****LITERATURE****TOTAL -35 MARKS**

In Section D, (Q10) questions have been designed to test a student's understanding of the passage and his/her ability to interpret, evaluate and respond to the given passage. As such, content assumes more importance than expression in the answers to these questions. Please do not hesitate to award full marks if the answer deserves it especially in the long answers.

**Q10. REFERENCE TO CONTEXT****TOTAL- 7 MARKS****Objective:** To test students' comprehension of poetry – local, global, interpretative, inferential and evaluative**Marking:**

7 marks

**Answers:**

**OPTION (1) SYMPATHY**

- a) Sympathy - ½ mark  
Paul Laurence Dunbar - ½ mark
- b) -to emphasize the fact that the scars are not new - 1 mark  
- to emphasize that the pain is an old one - 1 mark
- c) because of its repeated attempts at freeing itself from the cage, has hurt itself with wings bleeding and bosom sore. - 2 marks
- d) sings a song  
a prayer to God asking for freedom - 2 marks

**OPTION (2) ARS POETICA**

- a) Ars Poetica - ½ mark  
Archibald Macleish - ½ mark
- b) empty doorway; maple leaf; leaning grass; two lights above the sea - 1 mark  
grief; love - 1 mark
- c) a poem should be open to individual interpretation/should have an emotional appeal rather than an intellectual one - 2 marks
- d) symbols are suggestive/allow scope for interpretation/they convey abstract emotions and feelings through symbols (any two points) - 2 marks

**Q11. POETRY (Any two)**

**TOTAL 4X2=8 MARKS**

**Objectives:** To test the students' comprehension of poetry – local and global

**Marking:** Content: 3 marks

Expression: 1 mark

**SUGGESTED ANSWERS**

- a) ● It is a season of mists and mellow sunlight  
● just the right season for the fruits to ripen  
● a season of abundance - flowers and fruits

- b)
  - The loneliness of the lovers / their soliloquies
  - their feeling of indecisiveness whether their decision to separate has been the right one
- c)
  - He is upset at the changes he observes in his mother
  - Her frail and emaciated body makes him emotional - conveyed by the use of the phrase 'my tongue licks bark.'/his regret/sadness

**Q12. DRAMA THE MONKEY'S PAW**

**TOTAL-5 MARKS**

**Objective:** To test the students' ability to comprehend plays, understand characters etc.

**Marking:** Content: 3 marks

Expression: 2 marks

**OPTION (1) THE MONKEY'S PAW**

- the story of the Fakir
- the curse behind the monkey's paw
- the gruesome death of the first owner and later Herbert
- the eagerness of the second owner(Morris) to destroy it
- the setting of the play - on a cold winter evening; house situated next to the graveyard.
- the movement of the paw in Mr. White's hand
- the faces in the fire
- the second wish asking for the dead son to come alive again
- the frantic knocking on the door by Herbert's Spirit.
- the climax - none found when door is opened.

**(any four points to be included)**

**OPTION (2) AN ADVENTURE STORY**

- Perdiccas was an officer in Alexander's army,
- He had been sent by Alexander to escort Queen Mother from Babylon to the camp
- No, he had been asked to escort Queen Mother back.



**Q13. PROSE (Any two)**

**TOTAL 4X2=8 MARKS**

**Objective:** To test the students' ability to comprehend, interpret and evaluate prose texts

**Marking:** Content: 3 marks

Expression: 1 mark

- a) – Child's world exists only as far as he can see
- believes everyone who smiles is kind and everyone who laughs is happy/ happy times last forever
- Even the maidservant & the man servant, the ox and the donkey are happy
- In the end everyone will be saved from being burnt in the fires of Hell by the skin of their teeth
- spends most of the time happily playing in the garden

(any two points)

Adult world - run down machine, stuffy room, full of stabbing creatures/ burdened by responsibilities of life

- b) – There was no one to listen to his story / share his grief
- The people were too busy with their lives to care about an old poor man
- He was of no consequence to anyone
- The people were too 'insensitive / callous
- c) – She wonders whether the soldiers would want to see her performance at the time of a war
- is upset by the sadness of the people around her suffering the loss of family members in the war
- wants to shoot the enemy after she is exposed to scenes of battle at the front
- is upset by the trivial talks of the people around her after returning from the war front

**(any three points)**

**Q14. PROSE (LONG ANSWERS)**

**Total 7 marks**

**Objective:** To test the students' ability to comprehend prose texts globally, interpret and evaluate them.

Marking: Content - 4 marks

Expression - 3 marks

**OPTION (1) A ROOM 10' × 8'**

Note: Marks should be awarded for the students' creativity

**Suggested Value Points:**

- respect not accorded to elders
- elders treated as redundant material
- Mrs. Malik's insensitive attitude to her mother-in-law
- Mrs. Malik's daughter-in-law ignores her
- talks in English to exclude her from the conversation
- does not acknowledge mother-in-law's contribution in building the house
- gives her the store room to live in

**(any four points)**

**OPTION (2) THE JUDGEMENT OF PARIS**

**Suggested Value Points:**

Compare and Contrast 2 marks

Robichon - happy-go-lucky; robust; big built; great comedian; open; sporting; snobbish .

Quinquart - skinny; small built; talented comedian; secretive; loved Suzanne passionately.'

Judgement of Paris-both answers possible. 2 marks

Yes, because Quinquart outsmarted Robichon who had fooled the people of Paris

No, because Quinquart had not performed in front of the people. So he had not really fulfilled the conditions of the bet.

# MATHEMATICS

Time allowed : 3 hours

Maximum Marks : 100

## General Instructions:

1. All questions are compulsory.
2. The question paper consists of 29 questions divided into three sections, A, B and C. Section A comprises of 10 questions of one mark each, Section B comprises of 12 questions of four marks each and Section C comprises of 7 questions of six marks each.
3. All questions in Section A are to be answered in one word, one sentence or as per the exact requirement of the question.
4. There is no overall choice. However, internal choice has been provided in 4 questions of four marks each and 2 questions of six marks each. You have to attempt only one of the alternatives in all such questions.
5. Use of calculators is not permitted.

## QUESTION PAPER CODE 65/1/1

### SECTION A

Question numbers 1 to 10 carry 1 mark each.

1. If a line has direction ratios 2, -1, -2, then what are its direction cosines? 1
2. Find ' $\lambda$ ' when the projection of  $\mathbf{a} = \lambda\mathbf{i} + \mathbf{j} + 4\mathbf{k}$  on  $\mathbf{b} = 2\mathbf{i} + 6\mathbf{j} + 3\mathbf{k}$  is 4 units. 1
3. Find the sum of the vectors  $\mathbf{a} = \mathbf{i} - 2\mathbf{j} + \mathbf{k}$ ,  $\mathbf{b} = -2\mathbf{i} + 4\mathbf{j} + 5\mathbf{k}$  and  $\mathbf{c} = \mathbf{i} - 6\mathbf{j} - 7\mathbf{k}$ . 1
4. Evaluate:  $\int_2^3 \frac{1}{x} dx$ . 1
5. Evaluate  $\int (1-x)\sqrt{x} dx$ . 1

6. If  $\Delta = \begin{vmatrix} 5 & 3 & 8 \\ 2 & 0 & 1 \\ 1 & 2 & 3 \end{vmatrix}$ , write the minor of the element  $a_{23}$ . 1

7. If  $\begin{pmatrix} 2 & 3 \\ 5 & 7 \end{pmatrix} \begin{pmatrix} 1 & -3 \\ -2 & 4 \end{pmatrix} = \begin{pmatrix} -4 & 6 \\ -9 & x \end{pmatrix}$ , write the value of  $x$ . 1

8. Simplify:  $\cos \theta \begin{bmatrix} \cos \theta & \sin \theta \\ -\sin \theta & \cos \theta \end{bmatrix} + \sin \theta \begin{bmatrix} \sin \theta & -\cos \theta \\ \cos \theta & \sin \theta \end{bmatrix}$  1

9. Write the principal value of  $\cos^{-1}\left(\frac{1}{2}\right) - 2 \sin^{-1}\left(-\frac{1}{2}\right)$ . 1

10. Let \* be a 'binary' operation on  $\mathbb{N}$  given by  $a * b = \text{LCM}(a, b)$  for all  $a, b \in \mathbb{N}$ . Find  $5 * 7$ .

### SECTION - B

Question numbers 11 to 22 carry 4 marks each.

11. If  $(\cos x)^y = (\cos y)^x$ , find  $\frac{dy}{dx}$ . 4

**OR**

If  $\sin y = x \sin(a + y)$ , prove that  $\frac{dy}{dx} = \frac{\sin^2(a + y)}{\sin a}$ .

12. How many times must a man toss a fair coin, so that the probability of having at least one head is more than 80% ? 4

13. Find the Vector and Cartesian equations of the line passing through the point 4

$(1, 2, -4)$  and perpendicular to the two lines  $\frac{x-8}{3} = \frac{y+19}{-16} = \frac{z-10}{7}$  and

$$\frac{x-15}{3} = \frac{y-29}{8} = \frac{z-5}{-5}$$

14. If  $\vec{a}$ ,  $\vec{b}$ ,  $\vec{c}$  are three vectors such that  $|\vec{a}| = 5$ ,  $|\vec{b}| = 12$  and  $|\vec{c}| = 13$ , and  $\vec{a} + \vec{b} + \vec{c} = \vec{0}$ , find the value of  $\vec{a} \cdot \vec{b} + \vec{b} \cdot \vec{c} + \vec{c} \cdot \vec{a}$ . 4

15. Solve the following differential equation: 4

$$2x^2 \frac{dy}{dx} - 2xy + y^2 = 0.$$

16. Find the particular solution of the following differential equation; 4

$$\frac{dy}{dx} = 1 + x^2 + y^2 + x^2y^2, \text{ given that } y = 1 \text{ when } x = 0.$$

17. Evaluate:  $\int \sin x \sin 2x \sin 3x \, dx$

**OR**

$$\text{Evaluate: } \int \frac{2}{(1-x)(1+x^2)} \, dx$$

18. Find the point on the curve  $y = x^3 - 11x + 5$  at which the equation of tangent is  $y = x - 11$ . 4

**OR**

Using differentials, find the approximate value of  $\sqrt{49.5}$ .

19. If  $y = (\tan^{-1}x)^2$ , show that 4

$$(x^2 + 1)^2 \frac{d^2y}{dx^2} + 2x(x^2 + 1) \frac{dy}{dx} = 2.$$

20. Using properties of determinants, prove that 4

$$\begin{vmatrix} b+c & q+r & y+z \\ c+a & r+p & z+x \\ a+b & p+q & x+y \end{vmatrix} = 2 \begin{vmatrix} a & p & x \\ b & q & y \\ c & r & z \end{vmatrix}$$

21. Prove that  $\tan^{-1}\left(\frac{\cos x}{1 + \sin x}\right) = \frac{\pi}{4} - \frac{x}{2}$ ,  $x \in \left(-\frac{\pi}{2}, \frac{\pi}{2}\right)$ . 4

**OR**

Prove that  $\sin^{-1}\left(\frac{8}{17}\right) + \sin^{-1}\left(\frac{3}{5}\right) = \cos^{-1}\left(\frac{36}{85}\right)$ .

22. Let  $A = \mathbb{R} - \{3\}$  and  $B = \mathbb{R} - \{1\}$ . Consider the function  $f : A \rightarrow B$  defined by 4  
 $f(x) = \left(\frac{x-2}{x-3}\right)$ . Show that  $f$  is one-one and onto and hence find  $f^{-1}$ .

### SECTION - C

Question numbers 23 to 29 carry 6 marks each.

23. Find the equation of the plane determined by the points  $A(3, -1, 2)$ ,  $B(5, 2, 4)$  and  $C(-1, -1, 6)$  and hence find the distance between the plane and the point  $P(6, 5, 9)$ . 6

24. Of the students in a college, it is known that 60% reside in hostel and 40% are day scholars (not residing in hostel). Previous year results report that 30% of all students who reside in hostel attain 'A' grade and 20% of day scholars attain 'A' grade in their annual examination. At the end of the year, one student is chosen at random from the college and he has an 'A' grade, what is the probability that the student is a hostlier?

25. A manufacturer produces nuts and bolts. It takes 1 hour of work on machine A and 3 hours on machine B to produce a package of nuts. It takes 3 hours on machine A and 1 hour on machine B to produce a package of bolts. He earns a profit of ₹ 17.50 per package on nuts and ₹ 7 per package of bolts. How many packages of each should be produced each day so as to maximize his profits if he operates his machines for at the most 12 hours a day? Form the above as a linear programming problem and solve it graphically. 6

26.  $\int_0^{\pi/4} (\sqrt{\tan x} + \sqrt{\cot x}) dx = \sqrt{2} \cdot \frac{\pi}{2}$  6

**OR**

Evaluate  $\int_1^3 (2x^2 + 5x) dx$  as a limit of a sum.

27. Using the method of integration, find the area of the region bounded by the lines  $3x - 2y + 1 = 0$ ,  $2x + 3y - 21 = 0$  and  $x - 5y + 9 = 0$ . 6

28. Show that the height of a closed right circular cylinder of given surface and maximum volume, is equal to the diameter of its base. 6

29. Using matrices, solve the following system of linear equations:

$$x - y + 2z = 7$$

$$3x + 4y - 5z = -5$$

$$2x - y + 3z = 12$$

**OR**

Using elementary operations, find the inverse of the following matrix:

$$\begin{pmatrix} -1 & 1 & 2 \\ 1 & 2 & 3 \\ 3 & 1 & 1 \end{pmatrix}$$

**QUESTION PAPER CODE 65/1**  
**SECTION A**

Question numbers 1 to 10 carry 1 mark each.

1. The binary operation  $*$  :  $\mathbb{R} \times \mathbb{R} \rightarrow \mathbb{R}$  is defined as  $a * b = 2a + b$ .

Find  $(2 * 3) * 4$ .

2. Find the principal value of  $\tan^{-1} \sqrt{3} - \sec^{-1}(-2)$ .

3. Find the value of  $x + y$  from the following equation:

$$2 \begin{bmatrix} x & 5 \\ 7 & y-3 \end{bmatrix} + \begin{bmatrix} 3 & -4 \\ 1 & 2 \end{bmatrix} = \begin{bmatrix} 7 & 6 \\ 15 & 14 \end{bmatrix}$$

4. If  $A^T = \begin{bmatrix} 3 & 4 \\ -1 & 2 \\ 0 & 1 \end{bmatrix}$  and  $B = \begin{bmatrix} -1 & 2 & 1 \\ 1 & 2 & 3 \end{bmatrix}$ , then find  $A^T - B^T$ .
5. Let A be a square matrix of order  $3 \times 3$ . Write the value of  $|2A|$ , where  $|A| = 4$ .
6. Evaluate:
- $$\int_0^2 \sqrt{4-x^2} \, dx$$
7. Given  $\int e^x (\tan x + 1) \sec x \, dx = e^x f(x) + c$ .  
Write  $f(x)$  satisfying the above.
8. Write the value of  $(\hat{i} \times \hat{j}) \cdot \hat{k} + \hat{i} \cdot \hat{j}$
9. Find the scalar components of the vector  $\vec{AB}$  with initial point A(2, 1) and terminal point B(-5, 7).
10. Find the distance of the plane  $3x - 4y + 12z = 3$  from the origin.

### SECTION B

Question numbers 11 to 22 carry 4 marks each.

11. Prove the following:

$$\cos \left( \sin^{-1} \frac{3}{5} + \cot^{-1} \frac{3}{2} \right) = \frac{6}{5\sqrt{13}}$$

12. Using properties of determinants, show that

$$\Delta = \begin{vmatrix} b+c & a & a \\ b & c+a & b \\ c & c & a+b \end{vmatrix} = 4abc$$



13. Show that  $f : \mathbb{N} \rightarrow \mathbb{N}$ , given by

$$f(x) = \begin{cases} x + 1, & \text{if } x \text{ is odd} \\ x - 1, & \text{if } x \text{ is even} \end{cases}$$

is both one-one and onto.

**OR**

Consider the binary operations  $*$  :  $\mathbb{R} \times \mathbb{R} \rightarrow \mathbb{R}$  and  $\circ$  :  $\mathbb{R} \times \mathbb{R} \rightarrow \mathbb{R}$  defined as  $a * b = |a - b|$  and  $a \circ b = a$  for all  $a, b \in \mathbb{R}$ . Show that ' $*$ ' is commutative but not associative, ' $\circ$ ' is associative but not commutative.

14. If  $x = \sqrt{a^{\sin^{-1}t}}$ ,  $y = \sqrt{a^{\cos^{-1}t}}$ , show that  $\frac{dy}{dx} = -\frac{y}{x}$ .

**OR**

Differentiate  $\tan^{-1} \left[ \frac{\sqrt{1+x^2}-1}{x} \right]$  with respect to  $x$ .

15. If  $x = a(\cos t + t \sin t)$  and  $y = a(\sin t - t \cos t)$ ,  $0 < t < \frac{\pi}{2}$ ,

find  $\frac{d^2x}{dt^2}$ ,  $\frac{d^2y}{dt^2}$  and  $\frac{d^2y}{dx^2}$ .

16. A ladder 5 m long is leaning against a wall. The bottom of the ladder is pulled along the ground, away from the wall, at the rate of 2 cm/s. How fast is its height on the wall decreasing when the foot of the ladder is 4 m away from the wall ?

17. Evaluate:

$$\int_{-1}^2 |x^3 - x| dx$$

**OR**

Evaluate:

$$\int_0^{\pi} \frac{x \sin x}{1 + \cos^2 x} dx$$

18. Form the differential equation of the family of circles in the second quadrant and touching the coordinate axes.

**OR**

Find the particular solution of the differential equation

$$x(x^2 - 1) \frac{dy}{dx} = 1; y = 0 \text{ when } x = 2.$$

19. Solve the following differential equation:

$$(1 + x^2) dy + 2xy dx = \cot x dx; x \neq 0$$

20. Let  $\vec{a} = \hat{i} + 4\hat{j} + 2\hat{k}$ ,  $\vec{b} = 3\hat{i} - 2\hat{j} + 7\hat{k}$  and  $\vec{c} = 2\hat{i} - \hat{j} + 4\hat{k}$ . Find a vector  $\vec{p}$  which is perpendicular to both  $\vec{a}$  and  $\vec{b}$  and  $\vec{p} \cdot \vec{c} = 18$ .
21. Find the coordinates of the point where the line through the points A(3, 4, 1) and B(5, 1, 6) crosses the XY-plane.
22. Two cards are drawn simultaneously (without replacement) from a well-shuffled pack of 52 cards. Find the mean and variance of the number of red cards.

### SECTION C

Question numbers 23 to 29 carry 6 marks each.

23. Using matrices, solve the following system of equations:

$$2x + 3y + 3z = 5, x - 2y + z = -4, 3x - y - 2z = 3$$

24. Prove that the radius of the right circular cylinder of greatest curved surface area which can be inscribed in a given cone is half of that of the cone.

**OR**

An open box with a square base is to be made out of a given quantity of cardboard of area  $c^2$  square units. Show that the maximum volume of the box is  $\frac{c^3}{6\sqrt{3}}$  cubic units.

25. Evaluate:  $\int \frac{x \sin^{-1}x}{\sqrt{1-x^2}} dx$

**OR**

Evaluate:  $\int \frac{x^2 + 1}{(x-1)^2 (x+3)} dx$

26. Find the area of the region  $\{(x, y): x^2 + y^2 \leq 4, x + y \geq 2\}$ .

27. If the lines  $\frac{x-1}{-3} = \frac{y-2}{-2k} = \frac{z-3}{2}$  and  $\frac{x-1}{k} = \frac{y-2}{1} = \frac{z-3}{5}$  are perpendicular, find the value of  $k$  and hence find the equation of plane containing these lines.

28. Suppose a girl throws a die. If she gets a 5 or 6, she tosses a coin 3 times and notes the number of heads. If she gets 1, 2, 3 or 4 she tosses a coin once and notes whether a head or tail is obtained. If she obtained exactly one head, what is the probability that she threw 1, 2, 3 or 4 with the die?

29. A dietician wishes to mix two types of foods in such a way that the vitamin contents of the mixture contains at least 8 units of vitamin A and 10 units of vitamin C. Food I contains 2 units/kg of vitamin A and 1 unit/kg of vitamin C while Food II contains 1 unit/kg of vitamin A and 2 units/kg of vitamin C. It costs ` 5 per kg to purchase Food I and ` 7 per kg to purchase Food II. Determine the minimum cost of such a mixture. Formulate the above as a LPP and solve it graphically.

# Marking Scheme --- Mathematics

## *General Instructions :*

1. The Marking Scheme provides general guidelines to reduce subjectivity in the marking. The answers given in the Marking Scheme are suggested answers. The content is thus indicative. If a student has given any other answer which is different from the one given in the Marking Scheme, but conveys the meaning, such answers should be given full weightage.
2. Evaluation is to be done as per instructions provided in the marking scheme. It should not be done according to one's own interpretation or any other consideration — Marking Scheme should be strictly adhered to and religiously followed.
3. Alternative methods are accepted. Proportional marks are to be awarded.
4. In question(s) on differential equations, constant of integration has to be written.
5. If a candidate has attempted an extra question, marks obtained in the question attempted first should be retained and the other answer should be scored out.
6. A full scale of marks 0 to 100 has to be used. Please do not hesitate to award full marks if the answer deserves it.
7. Separate Marking Scheme for all the three sets has been given.
8. As per orders of the Hon'ble Supreme Court. The candidates would now be permitted to obtain photocopy of the Answer book on request on payment of the prescribed fee. All examiners/Head Examiners are once again reminded that they must ensure that evaluation is carried out strictly as per value points for each answer as given in the Marking Scheme.

QUESTION PAPER CODE 65/1/1

EXPECTED ANSWERS/VALUE POINTS

SECTION - A

Marks

1-10. 1.  $\frac{2}{3}, \frac{-1}{3}, \frac{-2}{3}$       2.  $\lambda = 5$       3.  $-4 \hat{j} - \hat{k}$       4.  $\log\left(\frac{3}{2}\right)$

5.  $\frac{2}{3}x^{3/2} - \frac{2}{5}x^{5/2} + c$       6.  $M_{2,3} = 7$       7. 13      8.  $\begin{pmatrix} 1 & 0 \\ 0 & 1 \end{pmatrix}$

9.  $\frac{2\pi}{3}$       10. 35       $1 \times 10 = 10 \text{ m}$

SECTION - B

11.  $(\cos x)^y = (\cos y)^x \Rightarrow y \log \cos x = x \log \cos y$        $\frac{1}{2} \text{ m}$

$\therefore y \cdot \frac{(-\sin x)}{\cos x} + \log \cos x \cdot \frac{dy}{dx} = x \cdot \frac{(-\sin y)}{\cos y} \frac{dy}{dx} + \log \cos y$        $1+1 \text{ m}$

$(\log \cos x + x \tan y) \frac{dy}{dx} = \log \cos y + y \tan x$        $1 \text{ m}$

$\therefore \frac{dy}{dx} = \frac{\log \cos y + y \tan x}{\log \cos x + x \tan y}$        $\frac{1}{2} \text{ m}$

OR

$\sin y = x \sin (a + y) \Rightarrow \cos y \frac{dy}{dx} = x \cos (a + y) \frac{dy}{dx} + \sin (a + y)$        $1 \text{ m}$

$\therefore \frac{dy}{dx} = \frac{\sin (a + y)}{\cos y - x \cos (a + y)}$        $1 \text{ m}$

$x = \frac{\sin y}{\sin (a + y)} \Rightarrow \frac{dy}{dx} = \frac{\sin (a + y)}{\cos y - \frac{\sin y}{\sin (a + y)} \cdot \cos (a + y)}$        $1 \text{ m}$

$\therefore \frac{dy}{dx} = \frac{\sin^2 (a + y)}{\sin (a + y) \cos y - \cos (a + y) \sin y} = \frac{\sin^2 (a + y)}{\sin a}$        $1 \text{ m}$

12. Let the coin be tossed n times

$$\therefore P(\text{getting at least one head}) > \frac{80}{100} \quad 1 \text{ m}$$

$$\therefore 1 - P(0) > \frac{8}{10} \Rightarrow P(0) < 1 - \frac{8}{10} = \frac{2}{10} = \frac{1}{5} \quad 1 \text{ m}$$

$$\therefore nC_0 \left(\frac{1}{2}\right)^0 \left(\frac{1}{2}\right)^n < \frac{1}{5} \quad \text{or} \quad \frac{1}{2^n} < \frac{1}{5} \quad \text{or} \quad 2^n > 5 \quad 1 \text{ m}$$

$$\Rightarrow n = 3 \quad 1 \text{ m}$$

13. Equations of the line can be written as  $\frac{x-1}{a} = \frac{y-2}{b} = \frac{z+4}{c}$   $\frac{1}{2} \text{ m}$

since the line is perpendicular to two given lines

$$\therefore 3a - 16b + 7c = 0 \quad \text{and} \quad 3a + 8b - 5c = 0 \quad \frac{1}{2} \text{ m}$$

$$\therefore \frac{a}{24} = \frac{b}{36} = \frac{c}{72} \quad 1 \text{ m}$$

Hence the equations of the line are

$$\frac{x-1}{24} = \frac{y-2}{36} = \frac{z+4}{72} \quad \text{or} \quad \frac{x-1}{2} = \frac{y-2}{3} = \frac{z+4}{6} \quad 1 \text{ m}$$

and the vector form is

$$\mathbf{r} = (\hat{i} + 2\hat{j} - 4\hat{k}) + \lambda (2\hat{i} + 3\hat{j} + 6\hat{k}) \quad 1 \text{ m}$$

14.  $\vec{a} + \vec{b} + \vec{c} = \vec{0} \Rightarrow (\vec{a} + \vec{b} + \vec{c})^2 = 0$   $\frac{1}{2} \text{ m}$

$$\Rightarrow \mathbf{a}^2 + \mathbf{b}^2 + \mathbf{c}^2 + 2(\vec{a} \cdot \vec{b} + \vec{b} \cdot \vec{c} + \vec{c} \cdot \vec{a}) = 0 \quad 1 \text{ m}$$

$$\text{or} \quad |\vec{a}|^2 + |\vec{b}|^2 + |\vec{c}|^2 + 2(\vec{a} \cdot \vec{b} + \vec{b} \cdot \vec{c} + \vec{c} \cdot \vec{a}) = 0 \quad 1 \text{ m}$$

$$\therefore \vec{a} \cdot \vec{b} + \vec{b} \cdot \vec{c} + \vec{c} \cdot \vec{a} = -\frac{1}{2} \left( |\vec{a}|^2 + |\vec{b}|^2 + |\vec{c}|^2 \right) \quad \frac{1}{2} \text{ m}$$

$$= -\frac{1}{2} (25 + 144 + 169) = -169 \quad 1 \text{ m}$$

$$15. \quad 2x^2 \frac{dy}{dx} - 2xy + y^2 = 0 \Rightarrow \frac{dy}{dx} = \frac{2xy - y^2}{2x^2} = \frac{2y/x - y^2/x^2}{2} \quad \frac{1}{2} \text{ m}$$

$$\text{Putting } \frac{y}{x} = v \text{ so that } y = vx \text{ and } \frac{dy}{dx} = v + x \frac{dv}{dx} \quad 1 \text{ m}$$

$$\therefore v + x \frac{dv}{dx} = v - \frac{1}{2} v^2 \quad \therefore x \frac{dv}{dx} = -\frac{1}{2} v^2 \quad \frac{1}{2} \text{ m}$$

$$\Rightarrow 2 \int \frac{dv}{v^2} = - \int \frac{dx}{x} \Rightarrow \frac{2}{v} = \log x + c \quad 1 \text{ m}$$

$$\therefore 2 \frac{x}{y} = \log x + c \quad \text{or} \quad y = \frac{2x}{\log x + c} \quad 1 \text{ m}$$

$$16. \quad \frac{dy}{dx} = 1 + x^2 + y^2 + x^2 y^2 = (1 + x^2) (1 + y^2) \quad \frac{1}{2} \text{ m}$$

$$\Rightarrow \int \frac{dy}{1+y^2} = \int (1+x^2) dx \quad 1 \text{ m}$$

$$\Rightarrow \tan^{-1} y = x + \frac{x^3}{3} + c \quad 1 \text{ m}$$

$$x = 0, y = 1 \Rightarrow c = \frac{\pi}{4} \quad 1 \text{ m}$$

$$\therefore \tan^{-1} y = x + \frac{x^3}{3} + \frac{\pi}{4} \quad \text{or} \quad y = \tan \left( \frac{\pi}{4} + x + \frac{x^3}{3} \right) \quad \frac{1}{2} \text{ m}$$

$$\begin{aligned}
17. \quad I &= \int \sin x \sin 2x \sin 3x \, dx = \frac{1}{2} \int 2 \sin 3x \sin x \sin 2x \, dx && \frac{1}{2} \text{ m} \\
&= \frac{1}{2} \int (\cos 2x - \cos 4x) \sin 2x \, dx = \frac{1}{2} \int (\sin 2x \cos 2x - \cos 4x \sin 2x) \, dx && \frac{1}{2} \text{ m} \\
&= \frac{1}{4} \int \sin 4x \, dx - \frac{1}{4} \int 2 \cos 4x \sin 2x \, dx && 1 \text{ m} \\
&= -\frac{1}{16} \cos 4x - \frac{1}{4} \int (\sin 6x - \sin 2x) \, dx && 1 \text{ m} \\
&= -\frac{1}{16} \cos 4x + \frac{1}{24} \cos 6x - \frac{1}{8} \cos 2x + c && 1 \text{ m}
\end{aligned}$$

**OR**

$$\frac{2}{(1-x)(1+x^2)} = \frac{A}{1-x} + \frac{Bx+C}{1+x^2} \quad \frac{1}{2} \text{ m}$$

$$2 = A(1+x^2) + (Bx+C)(1-x)$$

$$\Rightarrow 0 = A - B, \quad B - C = 0 \quad A + C = 2 \quad \Rightarrow A = B = C = 1 \quad 1\frac{1}{2} \text{ m}$$

$$\therefore \int \frac{2}{(1-x)(1+x^2)} \, dx = \int \frac{1}{1-x} \, dx + \int \frac{x+1}{x^2+1} \, dx \quad \frac{1}{2} \text{ m}$$

$$= -\log|1-x| + \frac{1}{2} \log(x^2+1) + \tan^{-1}x + c \quad 1\frac{1}{2} \text{ m}$$

$$18. \quad \text{slope of tangent, } y = x - 11 \text{ is } 1 \quad \frac{1}{2} \text{ m}$$

$$y = x^3 - 11x + 5 \Rightarrow \frac{dy}{dx} = 3x^2 - 11 \quad \frac{1}{2} \text{ m}$$

$$\text{If the point is } (x_1, y_1) \text{ then } 3x_1^2 - 11 = 1 \Rightarrow x_1 = \pm 2 \quad 1 \text{ m}$$

$$x_1 = 2 \text{ then } y_1 = 8 - 22 + 5 = -9 \text{ and if } x_1 = -2, \text{ then } y_1 = 19 \quad 1 \text{ m}$$

$$\text{since } (-2, 19) \text{ does not lie on the tangent } y = x - 11 \quad \frac{1}{2} \text{ m}$$

$$\therefore \text{ Required point is } (2, -9) \quad \frac{1}{2} \text{ m}$$



**OR**

$$\text{Let } y = \sqrt{x} \quad \therefore y + \Delta y = \sqrt{x + \Delta x} \quad \frac{1}{2} \text{ m}$$

$$\Rightarrow y + \frac{dy}{dx} \cdot \Delta x \simeq \sqrt{x + \Delta x} \quad \frac{1}{2} \text{ m}$$

$$\Rightarrow \sqrt{x} + \frac{1}{2\sqrt{x}} \cdot \Delta x \simeq \sqrt{x + \Delta x} \quad \frac{1}{2} \text{ m}$$

Putting  $x = 49$  and  $\Delta x = 0.5$  we get 1 m

$$\sqrt{49} + \frac{1}{2\sqrt{49}} (0.5) \simeq \sqrt{49.5} \quad \frac{1}{2} \text{ m}$$

$$\Rightarrow \sqrt{49.5} = 7 + \frac{1}{28} = 7.0357 \quad 1 \text{ m}$$

19.  $y = (\tan^{-1}x)^2 \Rightarrow \frac{dy}{dx} = 2 \tan^{-1}x \cdot \frac{1}{1+x^2} \quad 1 \text{ m}$

$$\Rightarrow (1+x^2) \frac{dy}{dx} = 2 \tan^{-1}x \quad 1 \text{ m}$$

$$\therefore (1+x^2) \frac{d^2y}{dx^2} + 2x \cdot \frac{dy}{dx} = \frac{2}{1+x^2} \quad 1 \text{ m}$$

$$\Rightarrow (1+x^2)^2 \frac{d^2y}{dx^2} + 2x(1+x^2) \frac{dy}{dx} = 2 \quad 1 \text{ m}$$

20. Using  $R_1 \rightarrow R_1 + R_2 + R_3$  we get

$$\text{LHS} = \begin{vmatrix} 2(a+b+c) & 2(p+q+r) & 2(x+y+z) \\ c+a & r+p & z+x \\ a+b & p+q & x+y \end{vmatrix} \quad 1 \text{ m}$$

$$= 2 \begin{vmatrix} a+b+c & p+q+r & x+y+z \\ c+a & r+p & z+x \\ a+b & p+q & x+y \end{vmatrix} \quad 1 \text{ m}$$

$$= 2 \begin{vmatrix} a+b+c & p+q+r & x+y+z \\ -b & -q & -y \\ -c & -r & -z \end{vmatrix} \quad \text{Using } R_2 \rightarrow R_2 - R_1, R_3 \rightarrow R_3 - R_1 \quad 1 \text{ m}$$

$$= 2 \begin{vmatrix} a & p & x \\ b & q & y \\ c & r & z \end{vmatrix} \quad \begin{array}{l} \text{Using } R_1 \rightarrow R_1 + R_2 + R_3 = \text{RHS} \\ R_2 \rightarrow -R_2, R_3 \rightarrow -R_3 \end{array} \quad 1 \text{ m}$$

$$21. \quad \tan^{-1} \left( \frac{\cos x}{1 + \sin x} \right) = \tan^{-1} \left( \frac{\sin \left( \frac{\pi}{2} - x \right)}{1 + \cos \left( \frac{\pi}{2} - x \right)} \right) \quad 1 \text{ m}$$

$$= \tan^{-1} \left( \frac{2 \sin \left( \frac{\pi}{4} - \frac{x}{2} \right) \cos \left( \frac{\pi}{4} - \frac{x}{2} \right)}{2 \cos^2 \left( \frac{\pi}{4} - \frac{x}{2} \right)} \right) = \tan^{-1} \left( \tan \left( \frac{\pi}{4} - \frac{x}{2} \right) \right) \quad 1+1 \text{ m}$$

$$= \frac{\pi}{4} - \frac{x}{2} \quad 1 \text{ m}$$

**OR**

$$\text{Writing } \sin^{-1} \left( \frac{8}{17} \right) = \tan^{-1} \frac{8}{15} \quad \text{and} \quad \sin^{-1} \left( \frac{3}{5} \right) = \tan^{-1} \frac{3}{4} \quad 1 \text{ m}$$

$$\therefore \text{LHS} = \tan^{-1} \frac{8}{15} + \tan^{-1} \frac{3}{4} = \tan^{-1} \left( \frac{\frac{8}{15} + \frac{3}{4}}{1 - \frac{8}{15} \cdot \frac{3}{4}} \right) = \tan^{-1} \left( \frac{77}{36} \right) \quad 1+1 \text{ m}$$

$$\text{Getting } \tan^{-1} \left( \frac{77}{36} \right) = \cos^{-1} \left( \frac{36}{85} \right) \quad 1 \text{ m}$$

22. Let  $x_1, x_2 \in A$  and  $f(x_1) = f(x_2)$  ½ m

$$\Rightarrow \frac{x_1 - 2}{x_1 - 3} = \frac{x_2 - 2}{x_2 - 3} \quad \therefore x_1 x_2 - 2x_2 - 3x_1 = x_1 x_2 - 2x_1 - 3x_2$$

$$\Rightarrow x_1 = x_2 \quad \text{1 m}$$

Hence  $f$  is 1-1

$$\text{Let } y \in B, \therefore y = f(x) \Rightarrow y = \frac{x - 2}{x - 3} \Rightarrow xy - 3y = x - 2$$

$$\text{or } x = \frac{3y - 2}{y - 1} \quad \text{½ m}$$

$$\text{since } y \neq 1 \text{ and } \frac{3y - 2}{y - 1} \neq 3 \therefore x \in A$$

Hence  $f$  is ONTO 1 m

$$\text{and } f^{-1}(y) = \frac{3y - 2}{y - 1} \quad \text{1 m}$$

### SECTION - C

23. Equation of the plane passing through A(3, -1, 2), B(5, 2, 4) and C(-1, -1, 6) is

$$\begin{vmatrix} x-3 & y+1 & z-2 \\ 2 & 3 & 2 \\ 6 & 3 & -2 \end{vmatrix} = 0 \quad \text{2 m}$$

$$\therefore (x - 3)(-12) - (y + 1)(-16) + (z - 2)(-12) = 0 \quad \text{1 m}$$

$$\text{i.e. } -12x + 16y - 12z + 76 = 0 \text{ or } 3x - 4y + 3z - 19 = 0 \quad \text{1 m}$$

Distance of point P(6, 5, 9) from the plane is

$$d = \frac{|18 - 20 + 27 - 19|}{\sqrt{9 + 16 + 9}} \quad \text{1 m}$$

$$= \frac{6}{\sqrt{34}} \quad \text{1 m}$$

24. Let  $E_1$  : selected student is a hostler

$E_2$  : selected student is a day scholar 1½ m

A : selected student attain 'A' grade in exam.

$$P(E_1) = \frac{60}{100}, \quad P(E_2) = \frac{40}{100} \quad 1 \text{ m}$$

$$P(A/E_1) = \frac{30}{100}, \quad P(A/E_2) = \frac{20}{100} \quad 1 \text{ m}$$

$$P(E_1/A) = \frac{P(E_1) \cdot P(A/E_1)}{P(E_1) \cdot P(A/E_1) + P(E_2) \cdot P(A/E_2)} \quad 1 \text{ m}$$

$$= \frac{\frac{60}{100} \cdot \frac{30}{100}}{\frac{60}{100} \cdot \frac{30}{100} + \frac{40}{100} \cdot \frac{20}{100}} = \frac{9}{13} \quad 1+½ \text{ m}$$

25. Let  $x$  packages of nuts and  $y$  packages of bolts be produced each day

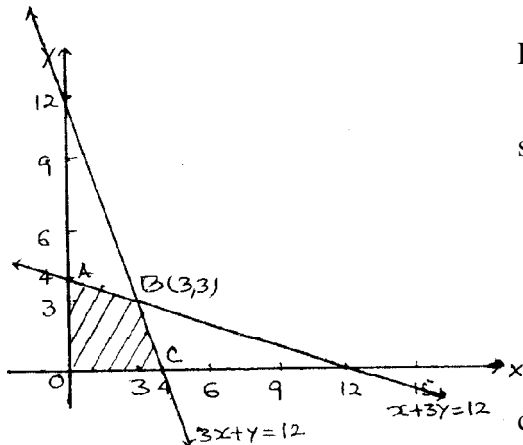

LPP is maximise  $P = 17.5x + 7y$  1 m

subject to  $x + 3y \leq 12$

$3x + y \leq 12$  2 m

$x \geq 0, y \geq 0$

correct graph 2 m

vertices of feasible region are A (0, 4), B (3, 3), C (4, 0)

Profit is Maximum at B (3, 3) i.e 3 packages of nuts and 3 packages of bolts 1 m

$$26. \quad I = \int_0^{\pi/4} (\sqrt{\tan x} + \sqrt{\cot x}) dx = \int_0^{\pi/4} \frac{\sin x + \cos x}{\sqrt{\sin x \cos x}} dx \quad 1 \text{ m}$$

Putting  $\sin x - \cos x = t$ , to get  $(\cos x + \sin x) dx = dt$  1 m

$$\text{and } \sin x \cos x = \frac{1-t^2}{2} \quad 1 \text{ m}$$

$$\therefore I = \sqrt{2} \int_{-1}^0 \frac{dt}{\sqrt{1-t^2}} = \sqrt{2} \cdot [\sin^{-1}t]_{-1}^0 \quad 1+1 \text{ m}$$

$$= \sqrt{2} (\sin^{-1}0 - \sin^{-1}(-1)) = \sqrt{2} \cdot \frac{\pi}{2} \quad 1 \text{ m}$$

**OR**

$$I = \int_1^3 (2x^2 + 5x) dx = \lim_{h \rightarrow 0} h [f(1) + f(1+h) + f(1+2h) + \dots + f(1+(n-1)h)] \quad 1 \text{ m}$$

$$\text{where } f(x) = 2x^2 + 5x \text{ and } h = \frac{2}{n} \text{ or } nh = 2$$

$$f(1) = 7$$

$$f(1+h) = 2(1+h)^2 + 5(1+h) = 7 + 9h + 2h^2$$

$$f(1+2h) = 2(1+2h)^2 + 5(1+2h) = 7 + 18h + 2 \cdot 2^2 h^2$$

$$f(1+3h) = 2(1+3h)^2 + 5(1+3h) = 7 + 27h + 2 \cdot 3^2 h^2$$

$$f(1+(n-1)h) = 7 + 9(n-1)h + 2 \cdot (n-1)^2 h^2$$

} 2 m

$$I = \lim_{h \rightarrow 0} h \left[ 7n + 9h \frac{n(n-1)}{2} + 2h^2 \cdot \frac{n(n-1)(2n-1)}{6} \right] \quad 1 \text{ m}$$

$$= \lim_{h \rightarrow 0} \left[ 7nh + \frac{9}{2} nh(nh-h) + \frac{1}{3} nh(nh-h)(2nh-h) \right] \quad 1 \text{ m}$$

$$= 14 + 18 + \frac{16}{3} = \frac{112}{3} \quad 1 \text{ m}$$

27. Let AB be  $3x - 2y + 1 = 0$ , BC be  $2x + 3y - 21 = 0$  and AC be  $x - 5y + 9 = 0$

solving to get A (1, 2), B (3, 5) and C (6, 3) 1½ m

correct figure ½ m

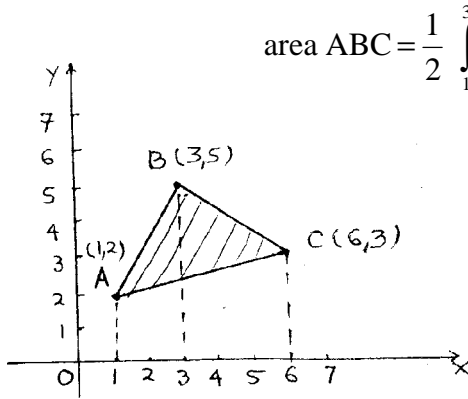

$$\text{area ABC} = \frac{1}{2} \int_1^3 (3x+1) dx + \frac{1}{3} \int_3^6 (21-2x) dx - \frac{1}{5} \int_1^6 (x+9) dx \quad 1\frac{1}{2} \text{ m}$$

$$= \frac{1}{12} (3x+1)^2 \Big|_1^3 + \frac{(21-2x)^2}{-12} \Big|_3^6 - \frac{(x+9)^2}{10} \Big|_1^6 \quad 1\frac{1}{2} \text{ m}$$

$$= 7 + 12 - \frac{25}{2} = \frac{13}{2} \text{ sq U.} \quad 1 \text{ m}$$

28.

surface area  $A = 2\pi rh + 2\pi r^2$  ½ m

$$\Rightarrow h = \frac{A - 2\pi r^2}{2\pi r} \dots\dots\dots(i) \quad 1\frac{1}{2} \text{ m}$$

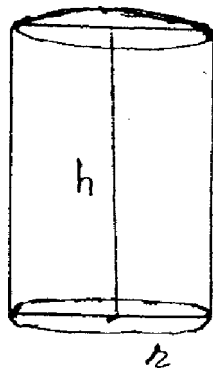

$$V = \pi r^2 h = \pi r^2 \left( \frac{A - 2\pi r^2}{2\pi r} \right) \quad 1 \text{ m}$$

$$= \frac{1}{2} \cdot [Ar - 2\pi r^3] \quad 1\frac{1}{2} \text{ m}$$

$$\frac{dv}{dr} = \frac{1}{2} [A - 6\pi r^2] \quad 1 \text{ m}$$

$$\frac{dv}{dr} = 0 \Rightarrow 6\pi r^2 = A = 2\pi rh + 2\pi r^2 \quad 1 \text{ m}$$

$$\Rightarrow 4\pi r^2 = 2\pi rh \Rightarrow h = 2r = \text{diameter} \quad 1\frac{1}{2} \text{ m}$$

$$\frac{d^2v}{dr^2} = \frac{1}{2} [-12\pi r] < 0 \therefore h = 2r \text{ will give max. volume.} \quad 1 \text{ m}$$

29. Given equations can be written as

$$\begin{pmatrix} 1 & -1 & 2 \\ 3 & 4 & -5 \\ 2 & -1 & 3 \end{pmatrix} \begin{pmatrix} x \\ y \\ z \end{pmatrix} = \begin{pmatrix} 7 \\ -5 \\ 12 \end{pmatrix} \text{ or } AX = B \quad 1 \text{ m}$$

$$|A| = 1(7) + 1(19) + 2(-11) = 4 \neq 0 \therefore X = A^{-1}B \quad 1 \text{ m}$$

$$\left. \begin{array}{lll} a_{11} = 7, & a_{12} = -19 & a_{13} = -11 \\ a_{21} = 1, & a_{22} = -1 & a_{23} = -1 \\ a_{31} = -3, & a_{32} = 11 & a_{33} = 7 \end{array} \right\} \begin{array}{l} \{ 1 \text{ mark for any four} \\ \text{correct cofactors} \} \end{array} \quad 2 \text{ m}$$

$$\Rightarrow A^{-1} = \frac{1}{4} \begin{pmatrix} 7 & 1 & -3 \\ -19 & -1 & 11 \\ -11 & -1 & 7 \end{pmatrix} \quad \frac{1}{2} \text{ m}$$

$$\therefore \begin{pmatrix} x \\ y \\ z \end{pmatrix} = \frac{1}{4} \begin{pmatrix} 7 & 1 & -3 \\ -19 & -1 & 11 \\ -11 & -1 & 7 \end{pmatrix} \begin{pmatrix} 7 \\ -5 \\ 12 \end{pmatrix} = \begin{pmatrix} 2 \\ 1 \\ 3 \end{pmatrix} \quad 1\frac{1}{2} \text{ m}$$

$$\therefore x = 2, y = 1, z = 3$$

**OR**

$$\text{let } A = \begin{pmatrix} -1 & 1 & 2 \\ 1 & 2 & 3 \\ 3 & 1 & 1 \end{pmatrix} \therefore \text{Writing } \begin{pmatrix} -1 & 1 & 2 \\ 1 & 2 & 3 \\ 3 & 1 & 1 \end{pmatrix} = A \begin{pmatrix} 1 & 0 & 0 \\ 0 & 1 & 0 \\ 0 & 0 & 1 \end{pmatrix} \quad 1 \text{ m}$$

$$c_1 \leftrightarrow c_2 \Rightarrow \begin{pmatrix} 1 & -1 & 2 \\ 2 & 1 & 3 \\ 1 & 3 & 1 \end{pmatrix} = A \begin{pmatrix} 0 & 1 & 0 \\ 1 & 0 & 0 \\ 0 & 0 & 1 \end{pmatrix} \quad \frac{1}{2} \text{ m}$$

$$\begin{array}{l} c_2 \rightarrow c_2 + c_1 \\ c_3 \rightarrow c_3 - 2c_1 \end{array} \begin{pmatrix} 1 & 0 & 0 \\ 2 & 3 & -1 \\ 1 & 4 & -1 \end{pmatrix} = A \begin{pmatrix} 0 & 1 & 0 \\ 1 & 1 & -2 \\ 0 & 0 & 1 \end{pmatrix} \quad 1 \text{ m}$$

$$\begin{array}{l} \mathbf{c}_1 \rightarrow \mathbf{c}_1 + 2\mathbf{c}_3 \\ \mathbf{c}_2 \rightarrow \mathbf{c}_2 + 2\mathbf{c}_3 \end{array} \begin{pmatrix} 1 & 0 & 0 \\ 0 & 1 & -1 \\ -1 & 2 & -1 \end{pmatrix} = \mathbf{A} \begin{pmatrix} 0 & 1 & 0 \\ -3 & -3 & -2 \\ 2 & 2 & 1 \end{pmatrix} \quad 1 \text{ m}$$

$$\mathbf{c}_3 \rightarrow \mathbf{c}_3 + \mathbf{c}_2 \begin{pmatrix} 1 & 0 & 0 \\ 0 & 1 & 0 \\ -1 & 2 & 1 \end{pmatrix} = \mathbf{A} \begin{pmatrix} 0 & 1 & 1 \\ -3 & -3 & -5 \\ 2 & 2 & 3 \end{pmatrix} \quad \frac{1}{2} \text{ m}$$

$$\begin{array}{l} \mathbf{c}_1 \rightarrow \mathbf{c}_1 + \mathbf{c}_3 \\ \mathbf{c}_2 \rightarrow \mathbf{c}_2 - 2\mathbf{c}_3 \end{array} \begin{pmatrix} 1 & 0 & 0 \\ 0 & 1 & 0 \\ 0 & 0 & 1 \end{pmatrix} = \mathbf{A} \begin{pmatrix} 1 & -1 & 1 \\ -8 & 7 & -5 \\ 5 & -4 & 3 \end{pmatrix} \quad 1 \text{ m}$$

$$\Rightarrow \mathbf{A}^{-1} = \begin{pmatrix} 1 & -1 & 1 \\ -8 & 7 & -5 \\ 5 & -4 & 3 \end{pmatrix} \quad 1 \text{ m}$$



QUESTION PAPER CODE 65/1

EXPECTED ANSWERS/VALUE POINTS

SECTION - A

Marks

1-10. 1. 18      2.  $\frac{-\pi}{3}$       3. 11      4.  $\begin{pmatrix} 4 & 3 \\ -3 & 0 \\ -1 & -2 \end{pmatrix}$

5. 32      6.  $\pi$       7.  $\sec x$       8. 1

9. -7, 6      10.  $\frac{3}{13}$

1×10 = 10 m

SECTION - B

11.  $\sin^{-1} \frac{3}{5} = \tan^{-1} \frac{3}{4}$ ,  $\cot^{-1} \frac{3}{2} = \tan^{-1} \frac{2}{3}$  1 m

$\therefore \cos \left( \tan^{-1} \frac{3}{4} + \tan^{-1} \frac{2}{3} \right) = \cos \left( \tan^{-1} \frac{\frac{3}{4} + \frac{2}{3}}{1 - \frac{3}{4} \cdot \frac{2}{3}} \right) = \cos \left( \tan^{-1} \frac{17}{6} \right)$  1+1 m

$= \cos \left( \cos^{-1} \frac{6}{5\sqrt{13}} \right) = \frac{6}{5\sqrt{13}} = \text{RHS}$  1 m

12. LHS =  $\Delta = \begin{vmatrix} b+c & a & a \\ b & c+a & b \\ c & c & a+b \end{vmatrix}$ ; Performing  $R_1 \rightarrow R_1 - R_2 - R_3$   $\Delta = \begin{vmatrix} 0 & -2c & -2b \\ b & c+a & b \\ c & c & a+b \end{vmatrix}$  1 m

$= \frac{1}{c} \begin{vmatrix} 0 & -2c & -2b \\ bc & (c+a)c & bc \\ c & c & a+b \end{vmatrix}$ , 1 m

Using  $R_2 \rightarrow R_2 - bR_3$  gives  $\Delta = \frac{1}{c} \begin{vmatrix} 0 & -2c & -2b \\ 0 & c(a+c-b) & b(c-a-b) \\ c & c & a+b \end{vmatrix}$  1 m

$$= \frac{1}{c} \cdot c \begin{vmatrix} -2c & -2b \\ (c+a-b)c & (c-a-b)b \end{vmatrix} = 2bc [(-c+a+b) + (c+a-b)] = 4abc$$

1 m

$$= \text{RHS}$$

13. Let  $x_1$  be odd and  $x_2$  be even and suppose  $f(x_1) = f(x_2)$

$$\Rightarrow x_1 + 1 = x_2 - 1 \Rightarrow x_2 - x_1 = 2 \text{ which is not possible}$$

1 m

similarly, if  $x_2$  is odd and  $x_1$  is even, not possible to have  $f(x_1) = f(x_2)$

$$\text{Let } x_1 \text{ and } x_2 \text{ be both odd } \Rightarrow f(x_1) = f(x_2) \Rightarrow x_1 = x_2$$

1 m

similarly, if  $x_1$  and  $x_1$  are both even, then also  $x_1 = x_2$

$\therefore f$  is one – one

Also, any odd number  $2r + 1$  in co-domain  $N$  is the image of  $(2r + 2)$  in domain  $N$

2 m

and any even number  $2r$  in the co-domain  $N$  is the image of  $(2r - 1)$  in domain  $N$

$\Rightarrow f$  is on to

**OR**

$$a * b = |a - b| \text{ and } b * a = |b - a|. \text{ also } |a - b| = |b - a| \text{ for all } a, b \in \mathbb{R}$$

1 m

$$\therefore a * b = b * a \Rightarrow * \text{ is commutative}$$

$$\text{Also, } [(-2) * 3] * 4 = |-2 - 3| * 4 = 5 * 4 = |5 - 4| = 1$$

$$\text{and } (-2) * [3 * 4] = (-2) * |3 - 4| = -2 * 1 = |-2 - 1| = 3$$

1 m

$\therefore *$  is not associative

$$2o3 = 2 \text{ and } 3o2 = 3 \Rightarrow o \text{ is not commutative}$$

1 m

for any  $a, b, c \in \mathbb{R}$   $(a o b) o c = a o c = a$  and  $a o (b o c) = a o b = a$

$\Rightarrow o$  is a associative

1 m

14.  $x = \sqrt{a^{\sin^{-1}t}} \Rightarrow 2 \log x = \sin^{-1}t \log a \Rightarrow \frac{dx}{dt} = \frac{x}{2} \left[ \log a \frac{1}{\sqrt{1-t^2}} \right]$

1½ m

$$y = \sqrt{a^{\cos^{-1}t}} \Rightarrow 2 \log y = \log a \cos^{-1}t \Rightarrow \frac{dy}{dt} = -\frac{y}{2} \left[ \log a \cdot \frac{1}{\sqrt{1-t^2}} \right]$$

1½ m

$$\therefore \frac{dy}{dx} = -\frac{y}{2} \cdot \frac{2}{x} \cdot \frac{\sqrt{1-t^2}}{\sqrt{1-t^2}} = -\frac{y}{x} \quad 1 \text{ m}$$

**OR**

Let  $x = \tan \theta$  1/2 m

$$\therefore \text{ Given expression becomes } y = \tan^{-1} \left( \frac{\sec \theta - 1}{\tan \theta} \right) = \tan^{-1} \left( \frac{1 - \cos \theta}{\sin \theta} \right) \quad 1+1/2 \text{ m}$$

$$\therefore y = \tan^{-1} \left( \tan \frac{\theta}{2} \right) = \frac{1}{2} \theta = \frac{1}{2} \tan^{-1} x \quad 1 \text{ m}$$

$$\therefore \frac{dy}{dx} = \frac{1}{2(1+x^2)} \quad 1 \text{ m}$$

**Alternative solution to Q. 14**

$$x = \sqrt{a^{\sin^{-1}t}}, \quad y = \sqrt{a^{\cos^{-1}t}}$$

$$\therefore x \cdot y = \sqrt{a^{\sin^{-1}t + \cos^{-1}t}} = \sqrt{a^{\pi/2}} = \text{constant} \dots\dots\dots (i) \quad 2 \text{ m}$$

Differentiating (i), we get

$$x \cdot \frac{dy}{dx} + y \cdot 1 = 0 \Rightarrow \frac{dy}{dx} = -\frac{y}{x} \quad 2 \text{ m}$$

15.  $x = a [\cos t + t \sin t] \Rightarrow \frac{dx}{dt} = a [-\sin t + \sin t + t \cos t] = at \cos t \quad 1 \text{ m}$

$$y = a [\sin t - t \cos t] \Rightarrow \frac{dy}{dt} = a [\cos t - \cos t + t \sin t] = at \sin t \quad 1 \text{ m}$$

$$\frac{d^2x}{dt^2} = a [\cos t - t \sin t], \Rightarrow \frac{d^2y}{dt^2} = a [\sin t + t \cos t] \quad 1 \text{ m}$$

$$\frac{dy}{dx} = \tan t \Rightarrow \frac{d^2y}{dx^2} = \sec^2 t \cdot \frac{dt}{dx} = \frac{\sec^2 t}{at \cos t} = \frac{\sec^3 t}{at} \quad 1 \text{ m}$$

16.

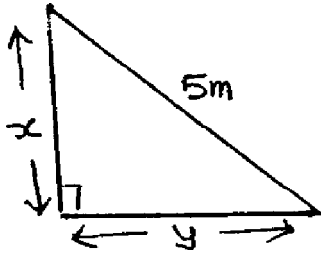

Figure

1/2 m

$$x^2 + y^2 = 25 \Rightarrow 2x \frac{dx}{dt} + 2y \frac{dy}{dt} = 0$$

1 m

when  $y = 4$  m,  $x = 3$  m

it is given that  $\frac{dy}{dt} = 2$  cm/sec

1/2+1/2

$$\therefore \frac{dx}{dt} = -\frac{4}{3} \cdot 2 = -\frac{8}{3} \Rightarrow \text{Height on the wall is decreasing}$$

at the rate of  $\frac{8}{3}$  cm/sec

1+1/2

$$17. \int_{-1}^2 |x^3 - x| dx = \int_{-1}^0 (x^3 - x) dx - \int_0^1 (x^3 - x) dx + \int_1^2 (x^3 - x) dx$$

1 1/2 m

$$= \int_{-1}^0 (x^3 - x) dx + \int_0^1 (x - x^3) dx + \int_1^2 (x^3 - x) dx$$

$$= \left[ \frac{x^4}{4} - \frac{x^2}{2} \right]_{-1}^0 + \left[ \frac{x^2}{2} - \frac{x^4}{4} \right]_0^1 + \left[ \frac{x^4}{4} - \frac{x^2}{2} \right]_1^2$$

1 1/2

$$= -\left(\frac{1}{4} - \frac{1}{2}\right) + \left(\frac{1}{2} - \frac{1}{4}\right) + (4 - 2) - \left(\frac{1}{4} - \frac{1}{2}\right) = \frac{11}{4}$$

1 m

**OR**

$$I = \int_0^{\pi} \frac{x \sin x}{1 + \cos^2 x} dx = \int_0^{\pi} \frac{(\pi - x) \sin(\pi - x)}{1 + \cos^2(\pi - x)} dx = \int_0^{\pi} \frac{(\pi - x) \sin x}{1 + \cos^2 x} dx$$

1 m

$$\therefore 2I = \pi \int_0^{\pi} \frac{\sin x}{1 + \cos^2 x} dx = \pi \int_{-1}^1 \frac{1}{1 + t^2} dx = 2\pi \int_0^1 \frac{dt}{1 + t^2} \text{ where } t = \cos x$$

1 1/2 m

$$= 2\pi \left[ \tan^{-1}t \right]_0^1 = 2\pi \frac{\pi}{4} = \frac{2\pi^2}{4} \quad 1 \text{ m}$$

$$\Rightarrow I = \frac{\pi^2}{4} \quad \frac{1}{2} \text{ m}$$

18.

Figure

$\frac{1}{2}$  m

Equation of family of circle is

$$(x+a)^2 + (y-a)^2 = a^2 \text{ or } x^2 + y^2 + 2ax - 2ay + a^2 = 0 \dots (i) \quad \frac{1}{2} \text{ m}$$

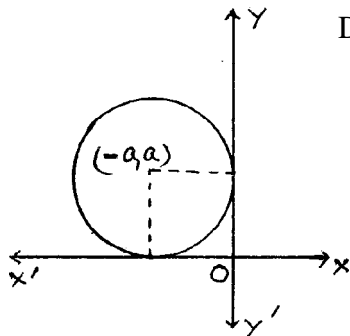

Differentiating we get  $2x + 2y \frac{dy}{dx} + 2a - 2a \frac{dy}{dx} = 0$

$$\Rightarrow x + y \frac{dy}{dx} = a \left( \frac{dy}{dx} - 1 \right) \quad 1 \text{ m}$$

$$\text{or } a = \frac{x + yy'}{y' - 1}, \text{ where } y' = \frac{dy}{dx} \quad \frac{1}{2} \text{ m}$$

substituting the value of a in (i) and simplifying

$$(xy' - x + x + yy')^2 + (yy' - y - x - yy')^2 = (x + yy')^2 \quad 1 \text{ m}$$

$$\text{or } (x + y)^2 [(y')^2 + 1] = (x + yy')^2 \quad \frac{1}{2} \text{ m}$$

**OR**

$$x(x^2 - 1) \frac{dy}{dx} = 1$$

$$\Rightarrow dy = \frac{1}{x(x^2 - 1)} dx \quad \frac{1}{2} \text{ m}$$

$$\Rightarrow \int dy = \int \frac{1}{\left(1 - \frac{1}{x^2}\right) x^3} dx \quad 1\frac{1}{2} \text{ m}$$

$$\Rightarrow y = \frac{1}{2} \log \left( 1 - \frac{1}{x^2} \right) + C \quad 1 \text{ m}$$

$$x = 2, y = 0 \Rightarrow C = -\frac{1}{2} \log \frac{3}{4} \quad \frac{1}{2} \text{ m}$$

$$\Rightarrow y = \frac{1}{2} \log \left( 1 - \frac{1}{x^2} \right) - \frac{1}{2} \log \frac{3}{4} \quad \frac{1}{2}$$

19. The given differential equation can be written as

$$\frac{dy}{dx} + \frac{2x}{1+x^2} y = \frac{\cot x}{1+x^2} \quad 1 \text{ m}$$

$$\text{I.F.} = e^{\log(1+x^2)} = 1+x^2 \quad 1 \text{ m}$$

$$\therefore \text{ the solution is } y \cdot (1+x^2) = \int \cot x \, dx + c \quad 1 \text{ m}$$

$$y(1+x^2) = \log |\sin x| + c \quad 1 \text{ m}$$

$$\text{or, } y = (1+x^2)^{-1} \log |\sin x| + c(1+x^2)^{-1}$$

20.  $\hat{\mathbf{p}}$  is  $\perp$  to both  $\hat{\mathbf{a}}$  and  $\hat{\mathbf{b}} \Rightarrow \hat{\mathbf{p}} = \lambda (\hat{\mathbf{a}} \times \hat{\mathbf{b}}) \quad 1\frac{1}{2} \text{ m}$

$$\text{Now } \hat{\mathbf{a}} \times \hat{\mathbf{b}} = \begin{vmatrix} \hat{\mathbf{i}} & \hat{\mathbf{j}} & \hat{\mathbf{k}} \\ 1 & 4 & 2 \\ 3 & -2 & 7 \end{vmatrix} = 32\hat{\mathbf{i}} - \hat{\mathbf{j}} - 14\hat{\mathbf{k}} \quad 1 \text{ m}$$

$$\text{Given that } \hat{\mathbf{p}} \cdot \hat{\mathbf{c}} = 18 \Rightarrow \lambda (32\hat{\mathbf{i}} - \hat{\mathbf{j}} - 14\hat{\mathbf{k}}) \cdot (2\hat{\mathbf{i}} - \hat{\mathbf{j}} + 4\hat{\mathbf{k}}) = 18 \quad 1 \text{ m}$$

$$\left. \begin{aligned} \text{or } \lambda(64+1-56) &= 18 \Rightarrow \lambda = 2 \\ \therefore \hat{\mathbf{p}} &= 64\hat{\mathbf{i}} - 2\hat{\mathbf{j}} - 28\hat{\mathbf{k}} \end{aligned} \right\} \quad \frac{1}{2} \text{ m}$$

21. Equations of line AB are

$$\frac{x-3}{2} = \frac{y-4}{-3} = \frac{z-1}{5} \dots\dots\dots(i) \quad 1\frac{1}{2}$$

the general point on (i) is

$$2\lambda + 3, -3\lambda + 4, 5\lambda + 1 \quad 1 \text{ m}$$

the line (i) crosses XY - plane, then  $z = 0$

$$\Rightarrow 5\lambda + 1 = 0 \Rightarrow \lambda = -\frac{1}{5} \quad 1 \text{ m}$$

$$\therefore \text{The point is } (13/5, 23/5, 0) \quad \frac{1}{2} \text{ m}$$

22. Number of red cards = 26

Let X be a random variable which can take values 1 m

0, 1, 2 where X is the no. of red cards selected

$\therefore$  X = 0 means 0 red card

$$P(X = 0) = \frac{{}^{26}C_2}{{}^{52}C_2} = \frac{26 \times 25}{52 \times 51} = \frac{25}{102}$$

$$P(X = 1) = \frac{{}^{26}C_1 \times {}^{26}C_1}{{}^{52}C_2} = \frac{26 \times 26 \times 2}{52 \times 51} = \frac{52}{102}$$

$$P(X = 2) = \frac{{}^{26}C_2}{{}^{52}C_2} = \frac{26 \times 25}{52 \times 51} = \frac{25}{102}$$

} 1\frac{1}{2}

Probability distribution of random variable X is

X	0	1	2
P(X)	25/102	52/102	25/102

$$\text{Mean} = \sum x P(X) = \frac{52 + 50}{102} = 1 \quad \frac{1}{2} \text{ m}$$

$$\text{variance} = \sum x^2 P(X) - (\sum xP(x))^2 = \frac{152}{102} - 1 = \frac{50}{102} \text{ or } \frac{25}{51} \quad 1 \text{ m}$$

**SECTION - C**

23. The given system of equations can be written as

$$AX = B, \text{ where } A = \begin{pmatrix} 2 & 3 & 3 \\ 1 & -2 & 1 \\ 3 & -1 & -2 \end{pmatrix}, X = \begin{pmatrix} x \\ y \\ z \end{pmatrix}, B = \begin{pmatrix} 5 \\ -4 \\ 3 \end{pmatrix} \quad 1 \text{ m}$$

$\therefore X = A^{-1} B$ , if  $A^{-1}$  exists

$$|A| = 40 \Rightarrow A^{-1} \text{ exists} \quad 1 \text{ m}$$

$$\text{Adj } A = \begin{pmatrix} 5 & 3 & 9 \\ 5 & -13 & 1 \\ 5 & 11 & -7 \end{pmatrix} \Rightarrow A^{-1} = \frac{1}{40} \begin{pmatrix} 5 & 3 & 9 \\ 5 & -13 & 1 \\ 5 & 11 & -7 \end{pmatrix} \quad 2+1/2 \text{ m}$$

$$\therefore X = \begin{pmatrix} x \\ y \\ z \end{pmatrix} = \frac{1}{40} \begin{pmatrix} 5 & 3 & 9 \\ 5 & -13 & 1 \\ 5 & 11 & -7 \end{pmatrix} \begin{pmatrix} 5 \\ -4 \\ 3 \end{pmatrix} = \begin{pmatrix} 1 \\ 2 \\ -1 \end{pmatrix} \quad 1/2 \text{ m}$$

$$\therefore x = 1, y = 2, z = -1$$

24.

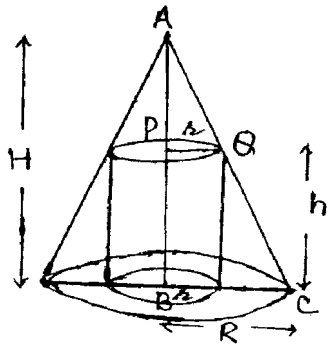

Figure 1 m

As  $\Delta APQ$  and  $\Delta ABC$  are similar

$$\Rightarrow \frac{H-h}{r} = \frac{H}{R} \Rightarrow h = \frac{RH-rH}{R} = \frac{R-r}{R} \cdot H$$

$$h = \left(1 - \frac{r}{R}\right) H \quad 1 \text{ m}$$

$$S = \text{curved surface area} = 2\pi r \left(1 - \frac{r}{R}\right) H = 2\pi H \left(r - \frac{r^2}{R}\right) \quad 1/2 \text{ m}$$

$$\frac{dS}{dr} = 2\pi H \left(1 - \frac{2r}{R}\right) \Rightarrow \frac{dS}{dr} = 0 \Rightarrow r = \frac{R}{2} \quad 1+1/2 \text{ m}$$



Finding  $\frac{d^2s}{dr^2}$  as negative  $\Rightarrow$  maximum 1 m

$\therefore$  for maximum curved surface area of cylinder, its radius is half that of the cone

**OR**

Let the length, breadth and height of open box be  $x, x, y$  units resp.

$$\therefore c^2 = x^2 + 4xy \Rightarrow y = \frac{c^2 - x^2}{4x} \quad \frac{1}{2} + \frac{1}{2} \text{ m}$$

$$\text{Volume } V \text{ of the box} = x^2y = x^2 \left( \frac{c^2 - x^2}{4x} \right) = \frac{c^2}{4}x - \frac{x^3}{4} \quad \frac{1}{2} + 1 \text{ m}$$

$$\frac{dv}{dx} = \frac{c^2}{4} - \frac{3}{4}x^2 \Rightarrow \frac{dv}{dx} = 0 \Rightarrow x = \frac{c}{\sqrt{3}} \quad 1 + \frac{1}{2} \text{ m}$$

$$\frac{d^2v}{dx^2} = -\frac{3}{2}x < 0 \Rightarrow \text{maximum} \quad \frac{1}{2} \text{ m}$$

$$\therefore x = \frac{c}{\sqrt{3}} \Rightarrow y = \frac{c}{2\sqrt{3}} \quad \frac{1}{2} \text{ m}$$

$$\text{maximum volume} = x^2y = \frac{c^2}{3} \cdot \frac{c}{2\sqrt{3}} = \frac{c^3}{6\sqrt{3}} \quad 1 \text{ m}$$

25.  $I = \int \frac{x \sin^{-1}x}{\sqrt{1-x^2}} dx$  ; Let  $x = \sin \theta \Rightarrow dx = \cos \theta d\theta$  1 m

$$= \int \frac{\sin \theta \cdot \theta}{\cos \theta} \cos \theta d\theta = \int \theta \sin \theta d\theta \quad 1\frac{1}{2} \text{ m}$$

$$= -\theta \cos \theta + \int \cos \theta d\theta = -\theta \cos \theta + \sin \theta + c \quad 1 + 1 \text{ m}$$

$$= -\sin^{-1}x \left( \sqrt{1-x^2} \right) + x + c \quad 1\frac{1}{2} \text{ m}$$

**OR**

$$I = \int \frac{x^2+1}{(x-1)^2(x+3)} dx$$

$$\text{Let } \frac{x^2+1}{(x-1)^2(x+3)} = \frac{A}{x-1} + \frac{B}{(x-1)^2} + \frac{C}{x+3} \quad 1 \text{ m}$$

$$\Rightarrow x^2+1 = A(x-1)(x+3) + B(x+3) + C(x-1)^2$$

$$\text{Getting the values } A = \frac{3}{8}, B = \frac{1}{2}, C = \frac{5}{8} \quad 1\frac{1}{2} \text{ m}$$

$$\therefore I = \int \frac{x^2+1}{(x-1)^2(x+3)} dx = \frac{3}{8} \int \frac{dx}{x-1} + \frac{5}{8} \int \frac{dx}{x+3} + \frac{1}{2} \int \frac{1}{(x-1)^2} dx \quad 1\frac{1}{2} \text{ m}$$

$$I = \frac{3}{8} \log|x-1| + \frac{5}{8} \log|x+3| - \frac{1}{2} \cdot \frac{1}{(x-1)} + C \quad \frac{1}{2} + \frac{1}{2} + 1 \text{ m}$$

26.

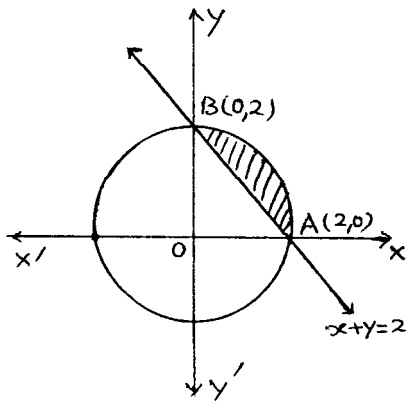

Finding points of intersection as  $x=0, 2$  1 m

Figure with correct shaded area 1 m

$$A = \int_0^2 \sqrt{4-x^2} dx - \int_0^2 (2-x) dx \quad 1+1 \text{ m}$$

$$= \left[ \frac{1}{2} x \sqrt{4-x^2} + 2 \sin^{-1} \frac{x}{2} \right]_0^2 - \left[ 2x - \frac{x^2}{2} \right]_0^2 \quad 1 \text{ m}$$

$$= \left( 0 + 2 \cdot \frac{\pi}{2} \right) - (4-2) = (\pi-2) \text{ sq. units} \quad 1 \text{ m}$$

27. The lines are  $\frac{x-1}{-3} = \frac{y-2}{-2k} = \frac{z-3}{2}$  and  $\frac{x-1}{k} = \frac{y-2}{1} = \frac{z-3}{5}$

the lines are perpendicular  $\Rightarrow (-3)k + (-2k)1 + 2(5) = 0$  1 m

$$-3k - 2k + 10 = 0 \Rightarrow k = 2 \quad 1 \text{ m}$$

$$\therefore \text{ The lines become } \frac{x-1}{-3} = \frac{y-2}{-4} = \frac{z-3}{2}, \frac{x-1}{2} = \frac{y-2}{1} = \frac{z-3}{5} \quad \frac{1}{2} + \frac{1}{2} \text{ m}$$

The equation of plane containing the lines is

$$\begin{vmatrix} x-1 & y-2 & z-3 \\ -3 & -4 & 2 \\ 2 & 1 & 5 \end{vmatrix} = 0 \quad 2 \text{ m}$$

$$\Rightarrow -22(x-1) - (y-2)(-19) + (z-3)5 = 0$$

$$\Rightarrow -22x + 19y + 5z = 31 \quad 1 \text{ m}$$

$$\text{or } 22x - 19y - 5z + 31 = 0$$

28. Let the events be

$E_1$  : Getting 5 or 6 in a single throw of a die

$E_2$  : Getting 1, 2, 3 or 4 in a single throw of a die

A : Getting exactly one Head 1½ m

$$P(E_1) = \frac{2}{6} = \frac{1}{3}, \quad P(E_2) = \frac{4}{6} = \frac{2}{3} \quad \frac{1}{2} + \frac{1}{2} \text{ m}$$

$$P(A/E_1) = {}_3C_1 \left(\frac{1}{2}\right)^1 \left(\frac{1}{2}\right)^2 = \frac{3}{8} \quad (\text{A coin is tossed thrice}) \quad \frac{1}{2} + \frac{1}{2} \text{ m}$$

$$P(A/E_2) = \frac{1}{2} \quad (\text{A coin is tossed once})$$

$$\therefore P(E_2/A) = \frac{P(E_2) \cdot P(A/E_2)}{\sum P(E_i) P(A/E_i)} \quad 1 \text{ m}$$

$$= \frac{\frac{2}{3} \times \frac{1}{2}}{\frac{1}{3} \times \frac{3}{8} + \frac{1}{2} \times \frac{2}{3}} = \frac{\frac{1}{3}}{\frac{1}{8} + \frac{1}{3}} = \frac{8}{11} \quad 1\frac{1}{2} \text{ m}$$

29. Let the mixture contain  $x$  kg of food I and  $y$  kg of food II

Getting the objective function as

$Z = 5x + 7y$  1 m

Getting the constraints

$2x + y \geq 8$

$x + 2y \geq 10$  2 m

$x, y \geq 0$

Correct graph 2 m

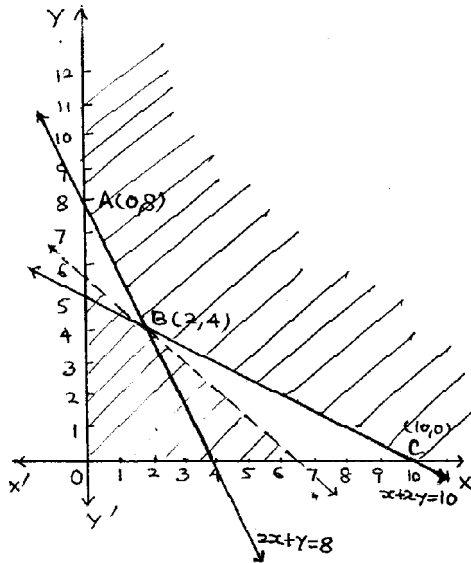

Getting the corners of feasible region as A (0, 8), B (2, 4), C (10, 0)

$Z_A = 5 \times 0 + 7 \times 8 = 56$

$Z_B = 5 \times 2 + 7 \times 4 = 38$  minimum

$Z_C = 5 \times 10 + 7 \times 0 = 50$

}  $\frac{1}{2}$  m

since  $5x + 7y < 38$  has

no common region with the feasible region

$\therefore$  For minimum cost

$x = 2$  kg and  $y = 4$  kg

$\frac{1}{2}$  m

# PHYSICS (Theory)

*Time allowed : 3 hours*

*Maximum Marks : 70*

## General Instructions:

- (i) All questions are compulsory.
- (ii) There are 30 questions in total. Questions 1 to 8 are very short answer type questions and carry one mark each.
- (iii) Questions 9 to 18 carry two marks each, questions 19 to 27 carry three marks each and questions 28 to 30 carry five marks each.
- (iv) There is no overall choice. However, an internal choice has been provided in one question of two marks, one question of three marks and all three questions of five marks each. You have to attempt only one of the given choices in such questions.
- (v) Use of calculators is **not** permitted. However, you may use log tables if necessary.
- (vi) You may use the following physical constants wherever necessary:

$$c = 3 \times 10^8 \text{ m/s}$$

$$h = 6.63 \times 10^{-34} \text{ Js}$$

$$e = 1.6 \times 10^{-19} \text{ C}$$

$$\mu_0 = 4\pi \times 10^{-7} \text{ T mA}^{-1}$$

$$\frac{1}{4\pi\epsilon_0} = 9 \times 10^9 \text{ Nm}^2\text{C}^{-2}$$

$$m_e = 9.1 \times 10^{-31} \text{ kg}$$

**QUESTION PAPER CODE 51/1/1**

1. When electrons drift in a metal from lower to higher potential, does it mean that all the free electrons of the metal are moving in the same direction ? 1
  
2. The horizontal component of the earth's magnetic field at a place is  $B$  and angle of dip is  $60^\circ$ . What is the value of vertical component of earth's magnetic field at equator ? 1
  
3. Show on a graph, the variation of resistivity with temperature for a typical semiconductor. 1
  
4. Why should electrostatic field be zero inside a conductor ? 1
  
5. Name the physical quantity which remains same for microwaves of wavelength 1 mm and UV radiations of  $1600 \text{ \AA}$  in vacuum. 1
  
6. Under what condition does a biconvex lens of glass having a certain refractive index act as a plane glass sheet when immersed in a liquid ? 1
  
7. Predict the directions of induced currents in metal rings 1 and 2 lying in the same plane where current  $I$  in the wire is increasing steadily. 1

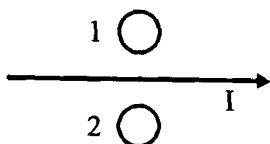

8. State de-Broglie hypothesis. 1
  
9. A ray of light, incident on an equilateral glass prism ( $\mu_g = \sqrt{3}$ ) moves parallel to the base line of the prism inside it. Find the angle of incidence for this ray. 2
  
10. Distinguish between 'Analog and Digital signals'. 2

**OR**

Mention the function of any two of the following used in communication system:

- (i) Transducer

- (ii) Repeater
- (iii) Transmitter
- (iv) Bandpass filter

11. A cell of emf  $E$  and internal resistance  $r$  is connected to two external resistances  $R_1$  and  $R_2$  and a perfect ammeter. The current in the circuit is measured in four different situations:

2

- (i) without any external resistance in the circuit
- (ii) with resistance  $R_1$  only
- (iii) with  $R_1$  and  $R_2$  in series combination
- (iv) with  $R_1$  and  $R_2$  in parallel combination

The currents measured in the four cases are 0.42 A, 1.05 A, 1.4 A and 4.2 A, but not necessarily in that order. Identify the currents corresponding to the four cases mentioned above.

12. The susceptibility of a magnetic material is  $-2.6 \times 10^{-5}$ . Identify the type of magnetic material and state its two properties.

2

13. Two identical circular wires P and Q each of radius  $R$  and carrying current 'I' are kept in perpendicular planes such that they have a common centre as shown in the figure. Find the magnitude and direction of the net magnetic field at the common centre of the two coils.

2

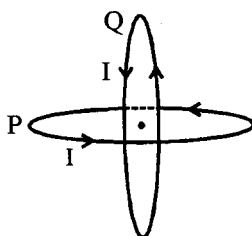

14. When an ideal capacitor is charged by a dc battery, no current flows. However, when an ac source is used, the current flows continuously. How does one explain this, based on the concept of displacement current ?

2

15. Draw a plot showing the variation of (i) electric field ( $E$ ) and (ii) electric potential ( $V$ ) with distance  $r$  due to a point charge  $Q$ .

2

16. Define self-inductance of a coil. Show that magnetic energy required to build up the current  $I$  in a coil of self inductance  $L$  is given by  $\frac{1}{2} LI^2$ . 2
17. The current in the forward bias is known to be more ( $\sim$ mA) than the current in the reverse bias ( $\sim$  $\mu$ A). What is the reason, then, to operate the photodiode in reverse bias? 2
18. A metallic rod of 'L' length is rotated with angular frequency of ' $\omega$ ' with one end hinged at the centre and the other end at the circumference of a circular metallic ring of radius  $L$ , about an axis passing through the centre and perpendicular to the plane of the ring. A constant and uniform magnetic field  $B$  parallel to the axis is present everywhere. Deduce the expression for the emf between the centre and the metallic ring. 2
19. The figure shows a series LCR circuit with  $L = 5.0$  H,  $C = 80 \mu\text{F}$ ,  $R = 40 \Omega$  connected to a variable frequency 240 V source. Calculate 3

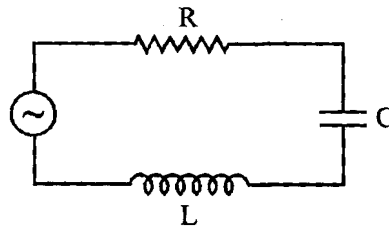

- (i) The angular frequency of the source which drives the circuit at resonance.
- (ii) The current at the resonating frequency.
- (iii) The rms potential drop across the capacitor at resonance.
20. A rectangular loop of wire of size  $4 \text{ cm} \times 10 \text{ cm}$  carries a steady current of 2 A. A straight long wire carrying 5 A current is kept near the loop as shown. If the loop and the wire are coplanar, find 3

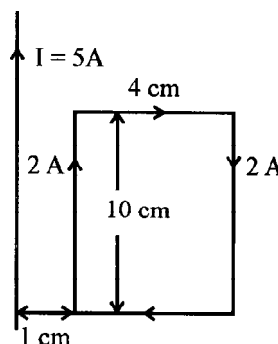



- (i) the torque acting on the loop and
- (ii) the magnitude and direction of the force on the loop due to the current carrying wire.
21. (a) Using Bohr's second postulate of quantization of orbital angular momentum show that the circumference of the electron in the  $n^{\text{th}}$  orbital state in hydrogen atom is  $n$  times the de Broglie wavelength associated with it. 3
- (b) The electron in hydrogen atom is initially in the third excited state. What is the maximum number of spectral lines which can be emitted when it finally moves to the ground state ?
22. In the figure a long uniform potentiometer wire AB is having a constant potential gradient along its length. The null points for the two primary cells of emfs  $\epsilon_1$  and  $\epsilon_2$  connected in the manner shown are obtained at a distance of 120 cm and 300 cm from the end A. Find (i)  $\epsilon_1/\epsilon_2$  and (ii) position of null point for the cell  $\epsilon_1$ .

How is the sensitivity of a potentiometer increased ? 3

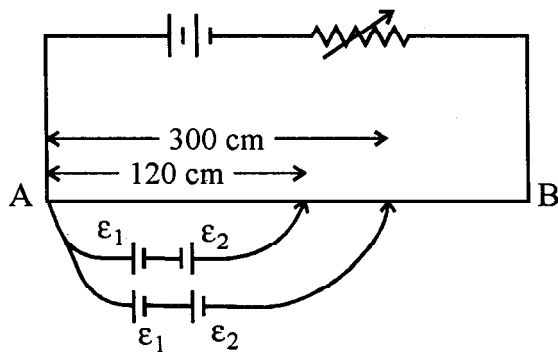

Using Kirchoffs rules determine the value of unknown resistance  $R$  in the circuit so that no current flows through  $4 \Omega$  resistance. Also find the potential difference between A and D.

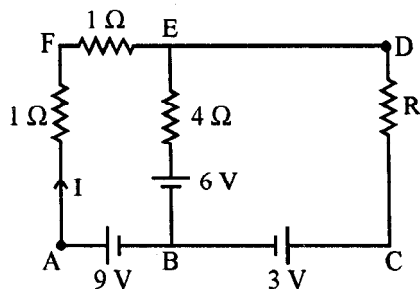

23. (i) What characteristic property of nuclear force explains the constancy of binding energy per nucleon ( $BE/A$ ) in the range of mass number 'A' lying  $30 < A < 170$  ?
- (ii) Show that the density of nucleus over a wide range of nuclei is constant-independent of mass number A. 3
24. Write any two factors which justify the need for modulating a signal. 3  
 Draw a diagram showing an amplitude modulated wave by superposing a modulating signal over a sinusoidal carrier wave.
25. Write Einstein's photoelectric equation. State clearly how this equation is obtained using the photon picture of electromagnetic radiation. 3  
 Write the three salient features observed in photoelectric effect which can be explained using this equation.
26. (a) Why are coherent sources necessary to produce a sustained interference pattern ? 3
- (b) In Young's double slit experiment using monochromatic light of wavelength  $\lambda$ , the intensity of light at a point on the screen where path difference is  $\lambda$ , is K units. Find out the intensity of light at a point where path difference is  $\lambda/3$ .
27. Use Huygens's principle to explain the formation of diffraction pattern due to a single slit illuminated by a monochromatic source of light. 3  
 When the width of the slit is made double the original width, how would this affect the size and intensity of the central diffraction band?
28. Explain the principle of a device that can build up high voltages of the order of a few million volts. 5  
 Draw a schematic diagram and explain the working of this device.  
 Is there any restriction on the upper limit of the high voltages set up in this machine? Explain.

**OR**

- (a) Define electric flux. Write its S.I. unit.

- (b) Using Gauss's law, prove that the electric field at a point due to a uniformly charged infinite plane sheet is independent of the distance from it.
- (c) How is the field directed if (i) the sheet is positively charged, (ii) negatively charged ?

29. Define magnifying power of a telescope. Write its expression.

5

A small telescope has an objective lens of focal length 150 cm and an eye piece of focal length 5 cm. If this telescope is used to view a 100 m high tower 3 km away, find the height of the final image when it is formed 25 cm away from the eye piece.

**OR**

How is the working of a telescope different from that of a microscope ?

The focal lengths of the objective and eyepiece of a microscope are 1.25 cm and 5 cm respectively. Find the position of the object relative to the objective in order to obtain an angular magnification of 30 in normal adjustment.

30. Draw a simple circuit of a CE transistor amplifier. Explain its working. Show that the

voltage gain,  $A_v$ , of the amplifier is given by  $A_v = -\frac{\beta_{ac} R_L}{r_i}$ , where  $\beta_{ac}$  is the current

gain,  $R_L$  is the load resistance and  $r_i$  is the input resistance of the transistor. What is the significance of the negative sign in the expression for the voltage gain ?

**OR**

(a) Draw the circuit diagram of a full wave rectifier using p-n junction diode. Explain its working and show the output, input waveforms.

(b) Show the output waveforms (Y) for the following inputs A and B of

- (i) OR gate
- (ii) NAND gate

5

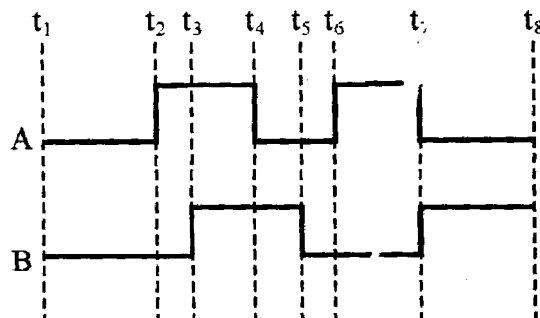

### QUESTION PAPER CODE 51/1

1. Two wires of equal length, one of copper and the other of manganin have the same resistance. Which wire is thicker? 1
2. What are the directions of electric and magnetic field vectors relative to each other and relative to the direction of propagation of electromagnetic waves? 1
3. How does the angular separation between fringes in single-slit diffraction experiment change when the distance of separation between the slit and screen is doubled? 1
4. A bar magnet is moved in the direction indicated by the arrow between two coils PQ and CD. Predict the directions of induced current in each coil. 1

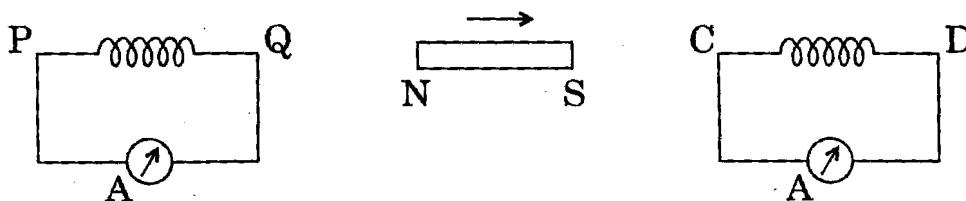

5. For the same value of angle of incidence, the angles of refraction in three media A, B and C are  $15^\circ$ ,  $25^\circ$  and  $35^\circ$  respectively. In which medium would the velocity of light be minimum? 1
6. A proton and an electron have same kinetic energy. Which one has greater de-Broglie wavelength and why? 1
7. Mention the two characteristic properties of the material suitable for making core of a transformer. 1
8. A charge 'q' is placed at the centre of a cube of side  $l$ . What is the electric flux passing through each face of the cube? 1
9. A test charge 'q' is moved without acceleration from A to C along the path from A to B and then from B to C in electric field E as shown in the figure. (i) Calculate the potential difference between A and C. (ii) At which point (of the two) is the electric potential more and why? 2

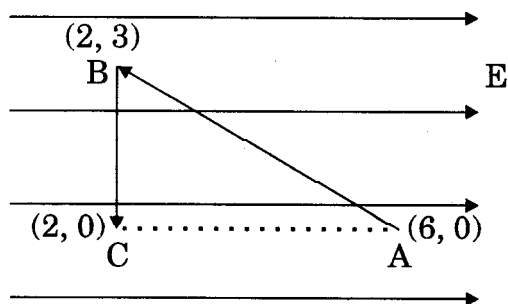

10. An electric dipole is held in a uniform electric field. 2
- (i) Show that the net force acting on it is zero.
- (ii) The dipole is aligned parallel to the field. Find the work done in rotating it through the angle of  $180^\circ$ .
11. State the underlying principle of a transformer. How is the large scale transmission of electric energy over long distances done with the use of transformers ? 2
12. A capacitor of capacitance 'C' is being charged by connecting it across a dc source along with an ammeter. Will the ammeter show a momentary deflection during the process of charging ? If so, how would you explain this momentary deflection and the resulting continuity of current in the circuit ? Write the expression for the current inside the capacitor. 2
13. An object AB is kept in front of a concave mirror as shown in the figure. 2

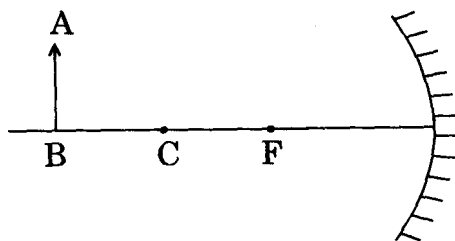

- (i) Complete the ray diagram showing the image formation of the object.
- (ii) How will the position and intensity of the image be affected if the lower half of the mirror's reflecting surface is painted black ?
14. Draw a labelled ray diagram of a reflecting telescope. Mention its two advantages over the refracting telescope. 2

15. Describe briefly with the help of a circuit diagram, how the flow of current carriers in a p-n-p transistor is regulated with emitter-base junction forward biased and base-collector junction reverse biased. 2
16. In the given block diagram of a receiver, identify the boxes labelled as X and Y and write their functions. 2

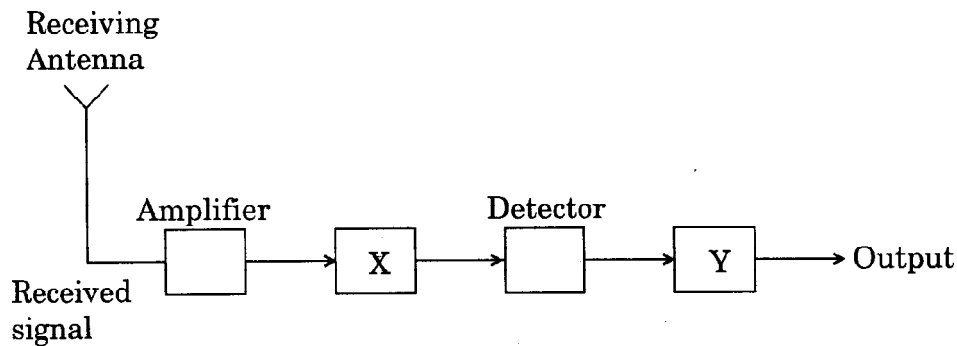

17. A light bulb is rated 100 W for 220 V ac supply of 50 Hz. Calculate
- the resistance of the bulb;
  - the rms current through the bulb.
- 2

**OR**

An alternating voltage given by  $V = 140 \sin 314 t$  is connected across a pure resistor of  $50 \Omega$ . Find

- the frequency of the source.
  - the rms current through the resistor.
18. A circular coil of  $N$  turns and radius  $R$  carries a current  $I$ . It is unwound and rewound to make another coil of radius  $R/2$ , current  $I$  remaining the same. Calculate the ratio of the magnetic moments of the new coil and the original coil. 2
19. Deduce the expression for the electrostatic energy stored in a capacitor of capacitance 'C' and having charge 'Q'. 3

How will the (i) energy stored and (ii) the electric field inside the capacitor be affected when it is completely filled with a dielectric material of dielectric constant 'K'?

20. Calculate the value of the resistance  $R$  in the circuit shown in the figure so that the current in the circuit is  $0.2\text{ A}$ . What would be the potential difference between points  $B$  and  $E$ ?

3

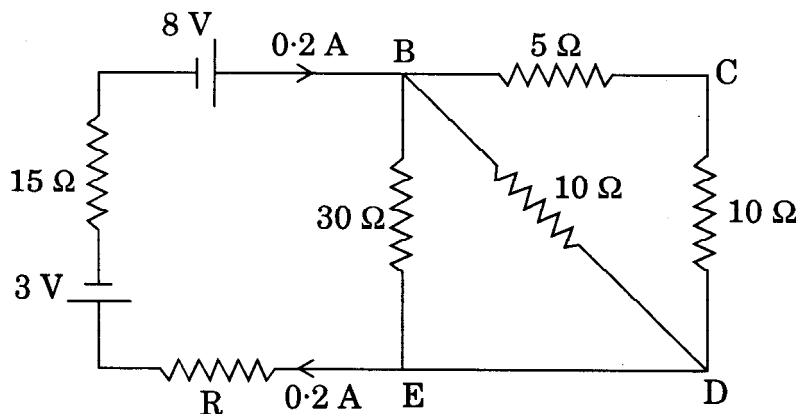

21. You are given three lenses  $L_1$ ,  $L_2$  and  $L_3$  each of focal length  $20\text{ cm}$ . An object is kept at  $40\text{ cm}$  in front of  $L_1$ , as shown. The final real image is formed at the focus  $I$  of  $L_3$ . Find the separations between  $L_1$ ,  $L_2$  and  $L_3$ .

3

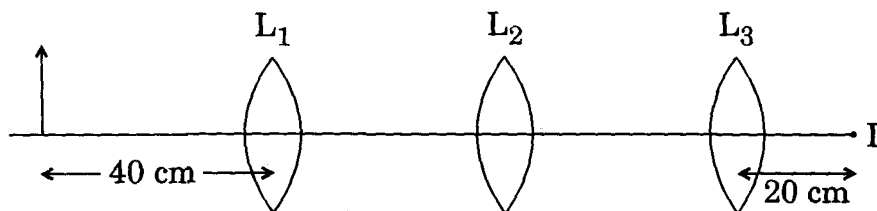

22. Define the terms (i) 'cut-off voltage' and (ii) 'threshold frequency' in relation to the phenomenon of photoelectric effect.

3

Using Einstein's photoelectric equation show how the cut-off voltage and threshold frequency for a given photosensitive material can be determined with the help of a suitable plot/graph.

23. A series LCR circuit is connected to an ac source. Using the phasor diagram, derive the expression for the impedance of the circuit. Plot a graph to show the variation of current with frequency of the source, explaining the nature of its variation.

3

24. Mention three different modes of propagation used in communication system. Explain with the help of a diagram how long distance communication can be achieved by ionospheric reflection of radio waves.

3

25. Draw a plot of potential energy of a pair of nucleons as a function of their separations. Mark the regions where the nuclear force is (i) attractive and (ii) repulsive. Write any two characteristic features of nuclear forces. 3

26. In a Geiger - Marsden experiment, calculate the distance of closest approach to the nucleus of  $Z = 80$ , when an  $\alpha$ -particle of 8 MeV energy impinges on it before it comes momentarily to rest and reverses its direction.  
How will the distance of closest approach be affected when the kinetic energy of the  $\alpha$ -particle is doubled ? 3

**OR**

The ground state energy of hydrogen atom is  $-13.6$  eV. If an electron makes a transition from an energy level  $-0.85$  eV to  $-3.4$  eV, calculate the wavelength of the spectral line emitted. To which series of hydrogen spectrum does this wavelength belong ? 3

27. Define relaxation time of the free electrons drifting in a conductor. How is it related to the drift velocity of free electrons ? Use this relation to deduce the expression for the electrical resistivity of the material. 3

28. (a) In Young's double slit experiment, derive the condition for (i) constructive interference and (ii) destructive interference at a point on the screen.  
(b) A beam of light consisting of two wavelengths, 800 nm and 600 nm is used to obtain the interference fringes in a Young's double slit experiment on a screen placed 1.4 m away. If the two slits are separated by 0.28 mm, calculate the least distance from the central bright maximum where the bright fringes of the two wavelengths coincide. 5

**OR**

(a) How does an unpolarized light incident on a polaroid get polarized?  
Describe briefly, with the help of a necessary diagram, the polarization of light by reflection from a transparent medium.  
(b) Two polaroids 'A' and 'B' are kept in crossed position. How should a third polaroid 'C' be placed between them so that the intensity of polarized light transmitted by polaroid B reduces to  $1/8$ th of the intensity of unpolarized light incident on A ? 5



29. (a) Describe briefly, with the help of a diagram, the role of the two important processes involved in the formation of a p-n junction.
- (b) Name the device which is used as a voltage regulator. Draw the necessary circuit diagram and explain its working. 5

**OR**

- (a) Explain briefly the principle on which a transistor-amplifier works as an oscillator. Draw the necessary circuit diagram and explain its working.
- (b) Identify the equivalent gate for the following circuit and write its truth table. 5

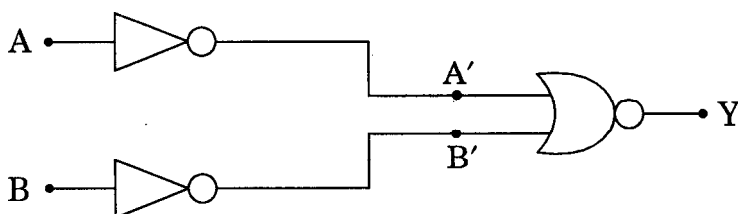

30. (a) Write the expression for the force,  $\vec{F}$ , acting on a charged particle of charge 'q', moving with a velocity  $\vec{v}$  in the presence of both electric field  $\vec{E}$  and magnetic field  $\vec{B}$ . Obtain the condition under which the particle moves undeflected through the fields.
- (b) A rectangular loop of size  $l \times b$  carrying a steady current  $I$  is placed in a uniform magnetic field  $\vec{B}$ . Prove that the torque  $\vec{\tau}$  acting on the loop is given by  $\vec{\tau} = \vec{m} \times \vec{B}$ , where  $\vec{m}$  is the magnetic moment of the loop. 5

**OR**

- (a) Explain, giving reasons, the basic difference in converting a galvanometer into (i) a voltmeter and (ii) an ammeter.
- (b) Two long straight parallel conductors carrying steady currents  $I_1$  and  $I_2$  are separated by a distance 'd'. Explain briefly, with the help of a suitable diagram, how the magnetic field due to one conductor acts on the other. Hence deduce the expression for the force acting between the two conductors. Mention the nature of this force. 5

## Marking Scheme — Physics (Theory)

### General Instructions :

1. The Marking Scheme provides general guidelines to reduce subjectivity in the marking. The answers given in the marking scheme are suggested answers. The content is thus indicative. If a student has given any other answer, which is different from the one given in the Marking Scheme, but conveys the meaning correctly, such answers should be given full weightage.
2. Evaluation is to be done as per instructions provided in the marking scheme. It should not be done according to one's own interpretation or any other consideration. Marking Scheme should be adhered to and religiously followed.
3. If a question has parts, please award marks in the right hand side for each part. Marks awarded for different part of the question should then be totalled up and written in the left hand margin and circled.
4. If a question does not have any parts, marks are to be awarded in the left hand margin only.
5. If a candidate has attempted an extra question, marks obtained in the question attempted first should be retained and the other answer should be scored out.
6. No marks are to be deducted for the cumulative effect of an error. The student should be penalized only once.
7. Deduct  $\frac{1}{2}$  mark for writing wrong units, missing units, in the final answer to numerical problems.
8. Formula can be taken as implied from the calculations even if not explicitly written.
9. In short answer type questions, asking for two features/characteristics/ properties, if a candidate writes three features, characteristics/properties or more, only the correct two should be evaluated.
10. Full marks should be awarded to a candidate if his/her answer in a numerical problem, is close to the value given in this scheme.

QUESTION PAPER CODE 55/1/1

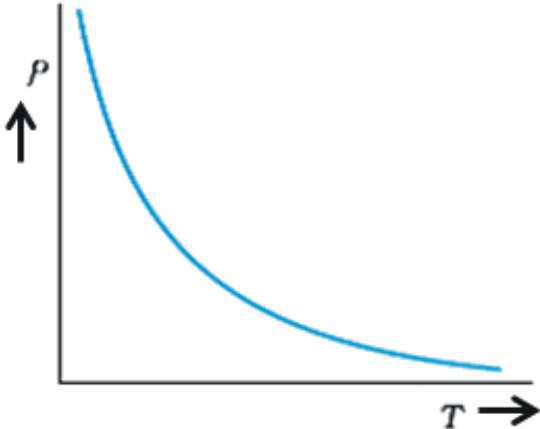
Q. No.	Expected Answer/value Points	Marks	Total Marks
1.	No	1	1
2.	Zero  (If the student writes $B_v = B \sin \delta$ , award $\frac{1}{2}$ mark)  [Also, if the student calculates the value of vertical component at that place as $B_v = B \sin 60^\circ$ , or $B_v = B_H \tan 60^\circ$ , award $\frac{1}{2}$ mark.]	1	1
3.		$\frac{1}{2}$	
	[If the graph is correct but the axis of the graph are not labelled, or labelled in an incorrect manner, award $\frac{1}{2}$ mark.]	$\frac{1}{2}$	1
4.	In the static situation, there is no current inside, or on the surface, of the conductor. Hence the electric field is zero everywhere inside the conductor  Alternatively:  i. since the charge inside the conductor is zero, the electric field is also zero.	1	
	or		
	Alternatively,  ii. since the conductor is uncharged so the electric field inside it is zero. (or any other logically valid answer.)		1

5. Speed (or velocity) 1 1
6. When the refractive index of glass is equal to the refractive index of the liquid.  
(Alternatively, when  $\mu_L = \mu_g$ ) 1 1
7. i. Clockwise in 1  $\frac{1}{2}$   
ii. Anticlockwise in 2  $\frac{1}{2}$   
(Alternatively, if the student correctly depicts the direction of flow of current diagrammatically, award full credit.) 1
8. De-Broglie hypothesis states that atomic particles of matter moving with a given velocity, (or momentum) can display wave like properties.  
[Award full 1 mark even if the student just writes  $\lambda = \frac{h}{p}$ ] 1 1
9. 

Formula	$\frac{1}{2}$
Substitution and calculation	$1 \frac{1}{2}$

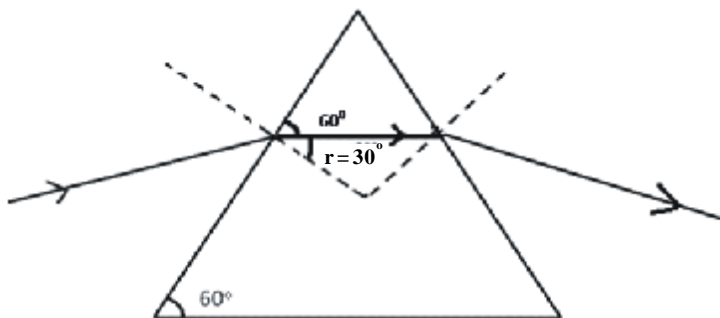

- From the diagram,  $r = 30^\circ$   $\frac{1}{2}$
- Also  $n_{21} = \frac{\sin i}{\sin r}$   $\frac{1}{2}$
- $\Rightarrow \sqrt{3} = \frac{\sin i}{\sin 30}$
- $\Rightarrow \sin i = \sqrt{3} \times \frac{1}{2}$   $\frac{1}{2}$
- $\Rightarrow i = 60^\circ$   $\frac{1}{2}$  2

10. 

Difference between Analog and Digital signals	2
-----------------------------------------------	---

Analog signals are continuous variations of voltage or current. 1

Digital signals are those which can take only discrete (stepwise) values. 1

(Give full credit even if the student depicts the above difference with the help of suitable diagrams.) 2

**OR**

Function of transducer/ repeater/ Transmitter/ bandpass filter(Any Two) 1+1
--------------------------------------------------------------------------------

Any two of the following 1+1

i. **Transducer:** —A device which converts energy from one form to another form.

ii. **Repeater:** — A repeater is a combination of a receiver and a transmitter.

iii. **Transmitter:**— A transmitter processes the incoming message signal so as to make it suitable for transmission through a channel and for its subsequent reception.

[Alternatively: A transmitter is a device used for sending the information in a communication system.]

iv. **Bandpass filter:**— A bandpass filter blocks lower and higher frequencies and allows only a band of frequencies to pass through. 2

11. 

Correct Identification	$\frac{1}{2} \times 4 = 2$
------------------------	----------------------------

i)  $i=4.2 \text{ A}$   $\frac{1}{2}$

ii)  $i=1.05 \text{ A}$   $\frac{1}{2}$

iii)  $i=0.42 \text{ A}$   $\frac{1}{2}$

iv)  $i=1.4 \text{ A}$   $\frac{1}{2}$

[If a student only writes the correct formulae in all four cases as given below but does not identify the values of current, award 1 mark only. For any two correct formulae, award  $\frac{1}{2}$  mark only.]

$$i) i = \frac{\epsilon}{r} \quad ii) i = \frac{\epsilon}{r+R_1} \quad iii) i = \frac{\epsilon}{r+R_1+R_2} \quad iv) i = \frac{\epsilon}{r+\frac{R_1 R_2}{R_1 + R_2}}$$

Award ½ mark if the student only writes that current is inversely proportional to the resistance.]

2

12.	Correct Identification	1
	Two Properties	1

Diamagnetic Material

1

Properties (any two)

- i. They have the tendency to move from stronger to weaker part of the external magnetic field.
- ii. They expel magnetic field lines.
- iii. Such substances are repelled by a magnet.
- iv. When placed in an external magnetic field, a net magnetic dipole moment is developed inside it which is in a direction opposite to that of the applied magnetic field.

½+½

(Give full credit for any other correct property)

[If the student identifies the substance as paramagnetic or ferromagnetic, but gives the properties of the same correctly, award 1 mark only.]

2

13.	Magnitude of net magnetic field	1½
	Direction	½

We have:  $B_p = B_Q = \frac{\mu_0 I}{2R}$  ½

$B_p$  is directed in the vertically upward direction while  $B_Q$  is directed along the horizontal direction. ½

$$\begin{aligned} \therefore B &= \sqrt{B_p^2 + B_Q^2} \\ &= \sqrt{2} B_p \end{aligned} \quad \text{½}$$

(If the student directly writes  $B = \sqrt{2} B_p$ , award this ½ mark)

$$\Rightarrow B = \sqrt{2} \frac{\mu_0 I}{2R} = \left( \frac{\mu_0 I}{\sqrt{2}R} \right)$$

The net magnetic field is directed at an angle of  $45^\circ$  with either of the fields.

[Award this  $\frac{1}{2}$  mark, even if the student takes  $B_Q$  along the vertically downward direction and writes that  $\theta = 135^\circ$ ]

2

14. 

Explanation	2
-------------	---

When an ideal capacitor is charged by dc battery, charge flows (momentarily) till the capacitor gets fully charged. When an ac source is connected then

conduction current  $i_c = \frac{dq}{dt}$  keep on flowing in the connecting wires.  $\frac{1}{2}$

Due to changing current, charge deposited on the plates of the capacitor changes with time. This causes change in electric field between the plates of the capacitor which causes the electric flux to change and gives rise to a displacement current in the region between the plates of the capacitor.  $\frac{1}{2}$

Displacement current  $i_d$  is given by  $i_d = \epsilon_0 \frac{dq_E}{dt}$   $\frac{1}{2}$

and is equal to the conduction current at all instants.  $\frac{1}{2}$

[Alternatively: If the student explains the continuous flow of current, for a capacitor connected to an AC source, on the basis of capacitive reactance, or the charging and discharging of a capacitor, award 1 mark only.] 2

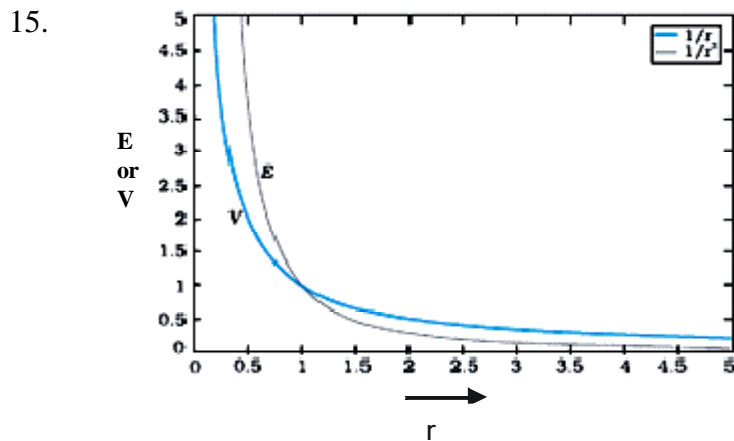

1+1

[If the graphs are not labelled, deduct  $\frac{1}{2}$  mark. Please award these marks even if the student draws two separate graphs, one each for E and V)

2

16.	Definition	1
	Derivation	1

Self Inductance is the property by which an opposing induced emf is produced in a coil due to a change in current, or magnetic flux, linked with the coil.

or Self inductance of a coil is numerically equal to the flux linked with the coil when the current through the coil is 1A.

or, self inductance of a coil is equal to the induced emf developed in the coil when the rate of change of current is the coil is one ampere per second. 1

Energy stored in an inductor:

Consider a source of emf connected to an inductor L. As the current starts growing, the opposing induced emf is given by

$$e = -L \frac{di}{dt} \quad \frac{1}{2}$$

If the source of emf sends a current  $i$  through the inductor for a small time  $dt$ , then the amount of work, done by the source, is given by

$$\begin{aligned} dW &= |e| i dt \\ &= Li \frac{di}{dt} dt \\ &= Lidi \end{aligned}$$

Hence the total amount of work done (by the source of emf) will the current increases from its initial value ( $i=0$ ) to its final value ( $I$ ) is given by

$$W = \int_0^i Lidi = L \int_0^i idi = L \left[ \frac{i^2}{2} \right]_0^i = \frac{1}{2} Li^2 \quad \frac{1}{2}$$

This work done gets stored in the inductor in the form of energy.

$$\therefore U = \frac{1}{2} LI^2$$

2



17. Explanation 2

Even though the current in forward bias has a larger magnitude, the change, due to changes in light intensity, in the minority carrier dominated reverse bias current, is more and is, therefore, more easily detectable. 2

Alternatively, any other logically valid explanation(including  $I$  based on the characteristic curves) to be given full credit. (Even if the student does not explicitly write that forward current is more, award full marks.) 2

18. Derivation 2

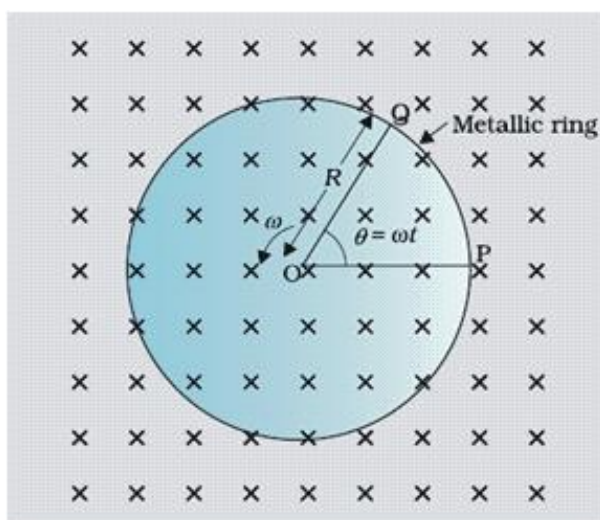

The magnitude of the emf, generated across a length  $dr$  of the rod, as it moves at right angles to the magnetic field, is given by

$$d\varepsilon = Bvdr. \quad 1$$

Therefore,

$$\varepsilon = \int d\varepsilon = \int_0^R Bv dr = \int_0^R B\omega r dr = \frac{B\omega R^2}{2} \quad 1$$

Alternatively, the potential difference across the resistor is equal to the induced emf and equals  $B \times$  (rate of change of area of loop). If  $\theta$  is the angle between the rod and the radius of the circle at P at time t, the area of the sector OPQ(as shown in the figure) is given by

$$\pi R^2 \times \frac{\theta}{2\pi} = \frac{1}{2} R^2 \theta \quad \frac{1}{2}$$

where  $R$  is the radius of the circle. Hence, the induced emf is

$$\varepsilon = B \times \frac{d}{dt} \left[ \frac{1}{2} R^2 \theta \right] = \frac{1}{2} BR^2 \frac{d\theta}{dt} = \frac{B\omega R^2}{2} \quad \frac{1}{2}+1 \quad 2$$

19.	Calculations of angular frequency	1
	Calculation of current	1
	Calculation of rms voltage across capacitor	1

(i)  $\omega = \frac{1}{\sqrt{LC}} \quad \frac{1}{2}$

$$= \frac{1}{\sqrt{5 \times 80 \times 10^{-6}}} = 50 \text{radian / s} \quad \frac{1}{2}$$

(ii) Current at resonance

$$I_{rms} = \frac{V_{rms}}{R} = \frac{240}{40} \text{ A} = 6 \text{ A} \quad \frac{1}{2}+\frac{1}{2}$$

(iii)  $V_{rms}$  across capacitor

$$V_{rms} = I_{rms} X_c \quad \frac{1}{2}$$

$$= 6 \times \frac{1}{50 \times 80 \times 10^{-6}} \text{ V}$$

$$= \frac{6 \times 10^6}{4 \times 10^3} \text{ V} = \frac{6000}{4} \text{ V} = 1500 \text{ V} \quad \frac{1}{2} \quad 3$$

20.	Calculations of torque	1
	Calculation of force	2

(i) Torque on the loop  $\frac{1}{2}$

$$\tau = MB \sin q$$

As  $M$  and  $B$  are parallel,  $q = 0$

Therefore,  $t = 0$  ½

(Award this one mark, if student writes torque  $\tau = 0$  directly)

(ii) Force acting on the loop

$$|F| = \frac{\mu_0 I_1 I_2}{2p} \mathbf{l} \left( \frac{1}{r_1} - \frac{1}{r_2} \right)$$
$$= 2 \times 10^{-7} \times 2 \times 2 \times 10^{-1} \left( \frac{1}{10^{-2}} - \frac{1}{5 \times 10^{-2}} \right) \text{N} \quad \frac{1}{2}$$

$$= \frac{8 \times 10^{-8}}{10^{-2}} \left( 1 - \frac{1}{5} \right) \text{N}$$

$$= 8 \times 10^{-6} \left( \frac{4}{5} \right) \text{N}$$

$$= 6.4 \times 10^{-6} \text{ N} \quad \frac{1}{2}$$

Direction : Towards conductor / Attractive ½

[Alternatively, If a student calculates the force by the following method, award the allotted 2 marks(for force calculation) as follows

$$\text{Magnetic field } B = \frac{\mu_0 I}{2pr}$$

$$|F_1| = I l B_1 \text{ (towards the conductor) } \quad \frac{1}{2} \text{ mark}$$

$$|F_2| = I l B_2 \text{ (away from the conductor) } \quad \frac{1}{2} \text{ mark}$$

$$|F| = I l (B_1 - B_2)$$

$$= I l \left( \frac{\mu_0 i}{2pr_1} - \frac{\mu_0 i}{2pr_2} \right) = \frac{\mu_0 i I l}{2p} \left( \frac{1}{r_1} - \frac{1}{r_2} \right)$$

$$|F| = \frac{2 \times 10^{-7} \times (2)^2 \times 10^{-1}}{10^{-2}} \left( 1 - \frac{1}{5} \right) \text{N}$$

$$= 6.4 \times 10^{-6} \text{ N} \quad \frac{1}{2} \text{ mark}$$

Direction : Towards the conductor / attractive ½ mark ]

3

21.	(i) Justifying of the result	2
	(ii) Maximum number of spectral lines	1

(i) According to Bohr's second postulate

$$mvr_n = \frac{nh}{2\pi} \quad 1$$

$$\Rightarrow 2\pi r_n = \frac{nh}{mv}$$

But  $\frac{h}{mv} = \frac{h}{p} = \lambda$

$$\therefore 2\pi r_n = n\lambda \quad \frac{1}{2}$$

[Note: If the student just writes  $mvr_n = \frac{nh}{2\pi}$  and writes  $\lambda = \frac{h}{p}$  award 2 marks)  $\frac{1}{2}$

ii) For third excited state  $n = 4$

for ground state  $n = 1$

Hence possible transitions are

$n_1 = 4$  to  $n_1 = 3, 2, 1$

$n_1 = 3$  to  $n_1 = 2, 1$

$n_1 = 2$  to  $n_1 = 1$

Total number of transitions = 6 1

Alternatively:

i. The student may show the transitions on the energy level diagram and count the total number as 6 award this 1 mark in such a case also

ii. If the student takes only the transitions to the ground state and writes

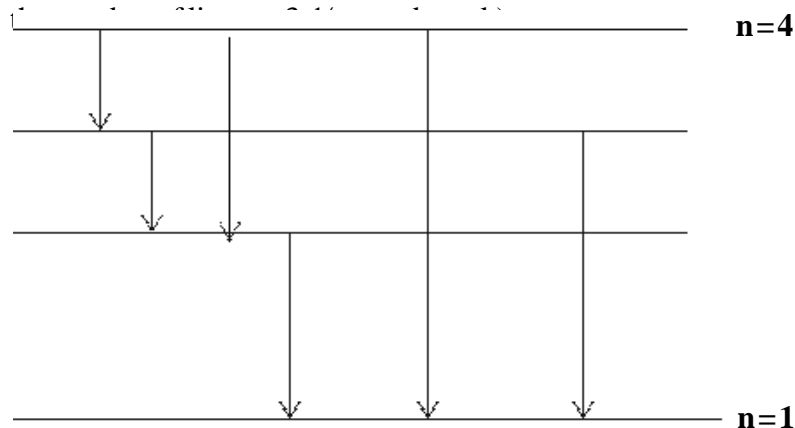

3

22.	(i) Finding $\frac{\epsilon_1}{\epsilon_2}$	2
	(ii) Position of null point for cell $\epsilon_1$	$\frac{1}{2}$
	(iii) Increase of sensitivity	$\frac{1}{2}$

(1)  $\epsilon_1 + \epsilon_2 = 300k$  ( $k$  is potential gradient in volt/cm)  $\frac{1}{2}$

$\epsilon_1 - \epsilon_2 = 120k$   $\frac{1}{2}$

$\Rightarrow \frac{\epsilon_1}{\epsilon_2} = \frac{7}{3}$  1

(ii)  $\epsilon_1 + \epsilon_2 = 300k$

$\therefore \epsilon_1 + \frac{3}{7} \epsilon_1 = 300k$

$\Rightarrow \epsilon_1 = 210k$

Therefore, balancing length for cell  $\epsilon_1$  is 210 cm  $\frac{1}{2}$

(Award this  $\frac{1}{2}$  mark even if the student writes  $\epsilon_1 = 210k$ )

(Award full marks for any other correct method)

(iii) By decreasing potential gradient.

[Or through Increasing length, reducing potential drop across wire, increasing resistance put in series with the main cell etc.]  $\frac{1}{2}$

3

**OR**

Calculation of unknown resistance (R)	1
Calculation of potential difference between A & D	2

Applying Kirchhoff's Voltage rule

for loop ABEFA

$-9 + 6 + 4 \times 0 + 2I = 0$   $\frac{1}{2}$

$2I - 3 = 0$

$I = \frac{3}{2} \text{ A} = 1.5\text{A}$   $\frac{1}{2}$

For loop BCDEB

$$3 + IR + 4 \times 0 - 6 = 0 \quad \frac{1}{2}$$

$$\therefore IR = 3$$

Substituting the value of current I,

$$\frac{3}{2} \times R = 3$$

$$\therefore R = 2 \Omega \quad \frac{1}{2}$$

Potential difference between A & D

Through path ABCD

$$+9V - 3V - IR = V_{AD}$$

$$+9 - 3 - \frac{3}{2} \times 2 = V_{AD}$$

$$\Rightarrow V_{AD} = 3V$$

[Alternatively through path AFD] 1

$$\frac{3}{2} \times 2 = V_{AD}$$

$$\Rightarrow V_{AD} = 3V \quad 3$$

(Note: Also accept any other logically valid approach leading to correct answer)

23.	(i) Naming the characteristic property	1
	(ii) Showing density of nucleus is independent of mass number	2

(i) Saturation / short range nature of nuclear forces. 1

(ii) We have

$$R = R_0 A^{1/3} \quad \frac{1}{2}$$

$$\therefore \text{Density } \rho = \frac{mA}{\frac{4}{3}\pi (R_0 A^{1/3})^3} \quad \frac{1}{2}$$

$$= \frac{m}{\frac{4}{3}\pi R_0^3} \quad \frac{1}{2}$$

Hence  $\rho$  is independent of A

(Here  $m$  is the mass of the nucleus.) 1/2

3

24.	Two factors justifying the need for modulation	1 + 1
	Diagram of amplitude modulated wave	1

Writing any two of the following factors: 1+1

- (i) Practical size of antenna / aerial
- (ii) Effective power radiated by an antenna
- (iii) To avoid mixing up of signals from different transmitters.

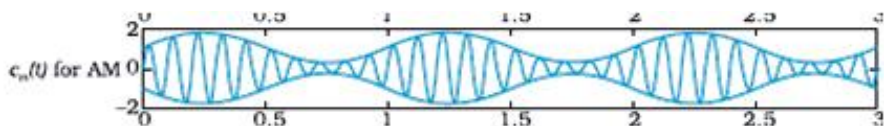

1

3

25.	Photoelectric equation	$\frac{1}{2}$
	Obtaining this equation from photon picture	1
	Three salient features	$\frac{1}{2} + \frac{1}{2} + \frac{1}{2}$

$$h \nu = \phi_0 + K_{\max} \quad \frac{1}{2}$$

Energy ( $h \nu$ ), carried by a photon of frequency  $\nu$ , is absorbed (by the electrons on the surface.) to:

- (1) overcome the work function of metal ( $\phi_0$ )  $\frac{1}{2}$
- (2) Impart maximum kinetic energy to the emitted electron ( $K_{\max}$ )  $\frac{1}{2}$

$$\therefore h \nu = \phi_0 + K_{\max}$$

[Note: Award only one mark for writing the photoelectric equation, when a student also explains the symbols used in the equation]

Three salient features (Any three):

- (i) Cut-off potential of the emitted electrons is proportional to  $\nu$
- (ii) maximum kinetic energy is independent of the intensity of incident radiations.
- (iii) Photoelectric emission of electrons is possible only when  $\nu > \nu_0 = \frac{\phi_0}{h}$   $\frac{1}{2} + \frac{1}{2}$
- (iv) Emission of electrons is instantaneous  $\frac{1}{2}$

26.	a) Need for coherent sources (to produce sustained interference)	1
	b) Calculation of intensity	2

- (a) Coherent sources are needed to ensure that the positions of maxima and minima do not change with time.

Alternatively,

Coherent sources have constant phase difference and, therefore, produce a sustained interference pattern. 1

(b)

$$I = 4 I_0 \cos^2 \frac{\theta}{2}$$

[Alternatively,  $I = I_1 + I_2 + 2 \sqrt{I_1 I_2} \cos \theta$ ] 1/2

For path difference  $\lambda$ , phase difference

$$\phi = 2\pi$$

$$\text{Hence, } K = 4 I_0 \cos^2 \pi = 4 I_0$$

For path difference  $\frac{\lambda}{3}$  1/2

$$\text{Phase difference } \phi = \frac{2\pi}{3}$$

Intensity

$$I' = 4 I_0 \cos^2 \frac{\pi}{3} \quad 1/2$$

$$= 4 I_0 \left( \frac{1}{2} \right)^2 = I_0$$

Therefore,  $I' = \frac{K}{4}$  1/2 3

27.	Explanation of the formation of diffraction pattern using Huygens's principle	2
	Effect of width of slit on the size and intensity of central maxima	1/2 + 1/2

Explanation :

As per Huygen's Principle

Net effect at any point



= sum total of contribution of all wavelets with proper phase difference 1/2

At the central Point (O)

Contribution from each half in  $SS_1$  is in phase with that from the corresponding part in  $SS_2$ . Hence, O is a maxima 1/2



At the point M where  $SM - SM_1 = \lambda/2$

Phase difference between each wavelet from  $SS_1$  and corresponding wavelet from  $SS_2 = \lambda/2$

Hence, M would be a minima.

All such points (path difference =  $n\lambda/2$ ) are also minima.

Similarly, all points, for which path difference =  $(2n+1)\lambda/2$ , are maxima but with decreasing intensity. 1/2

From the figure

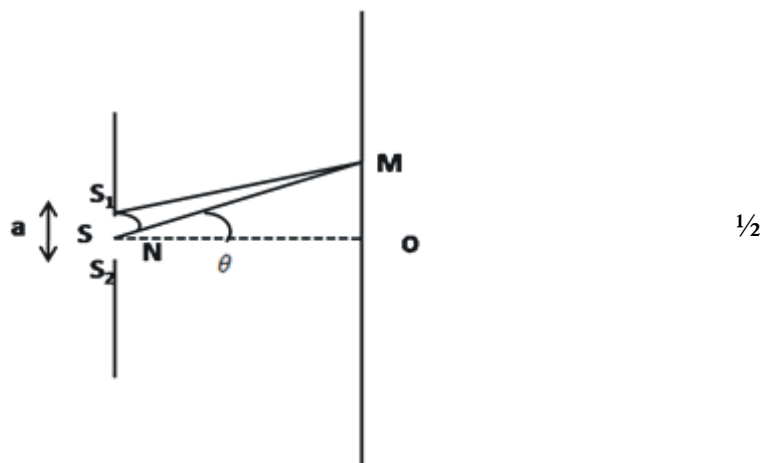

Half angular width of central maxima =  $\lambda/a$

$\therefore$ , Size of central maxima will be reduced to half

and intensity of central maxima will be four times

[Note: award this last one mark even when the student writes the 'effect on size' only.]

1/2

1/2

3

28.	Principle of device	1
	Diagram and explanation of working	2 + 1
	Restriction	1

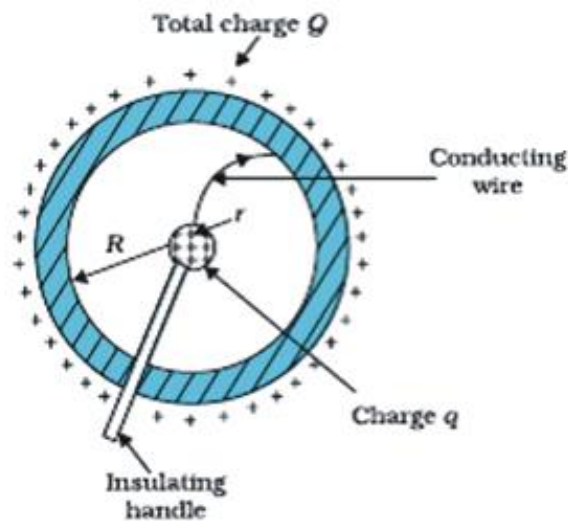

Principle: The inner smaller sphere is at a higher potential than the larger outer sphere. Hence even a small positive charge, on the small sphere, flows immediately to the larger sphere when both are connected by a conducting wire, even when the charge on the larger sphere is quite large.

[Alternatively:

- i. Surface charge density of sharp points of a conductor is extremely high and hence charge is continuously being sprayed out from sharp points.
- ii. Charge given to inner surface of a hollow conductor is transferred to its outer surface and is uniformly distributed over it.]

1

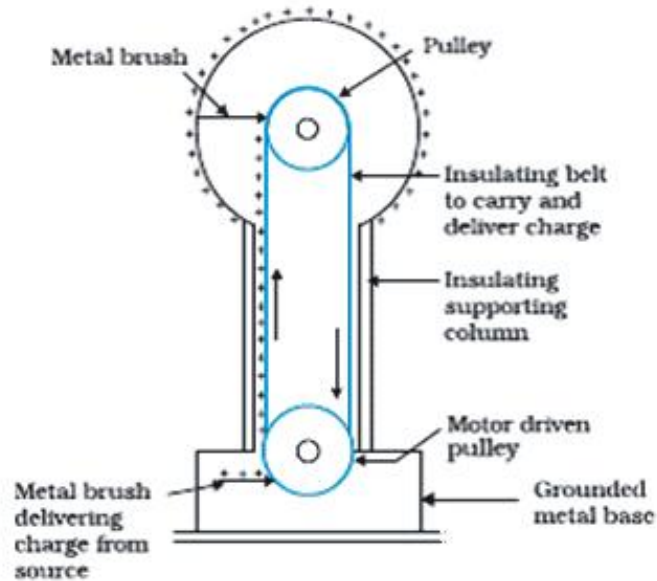

2

**Working:** The belt continuously carries positive charge, sprayed on to it by a brush at ground level, to the top. There it transfers its positive charge to another conducting brush connected to the large shell. Thus positive charge is transferred to the shell, where it spreads out uniformly on the outer surface. In this way voltage difference is built up.

1

Yes, high voltages can be built up only upto the breakdown field of the surrounding medium.

1

5

(Award marks if student describes any other correct device.)

**OR**

a)	Definition of Electric flux	1
	SI unit	$\frac{1}{2}$
b)	Derivation	$2\frac{1}{2}$
c)	Direction of field	$\frac{1}{2} + \frac{1}{2}$

- a) Electric flux is defined as the number of electric field lines passing through an area normal to them.

Alternatively

Surface integral of the electric field is defined as the electric flux through a closed surface

1

$$\phi = \oint \vec{E} \cdot d\vec{S} \quad \frac{1}{2}$$

SI unit :  $\frac{N \cdot m^2}{C}$  or volt. metre

(a)

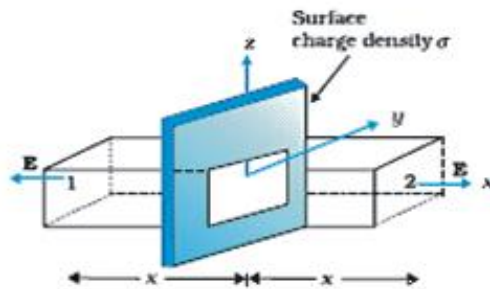

1

Outward flux through the gaussian surface, is

$$2EA = \sigma A / \epsilon_0 \quad \frac{1}{2}$$

$$\therefore E = \sigma / 2\epsilon_0 \quad \frac{1}{2}$$

Vectorically,

$$\vec{E} = \frac{\sigma}{2\epsilon_0} \hat{n},$$

where  $\hat{n}$  is a unit vector normal to the plane, away from it. 1/2

Hence, Electric field is independent of the distance from sheet.

(i) for positively charged sheet

$\rightarrow$  away from the sheet 1/2

for negatively charged sheet

$\rightarrow$  towards the plane sheet 1/2

5

29.	Definition of Magnifying power	1
	Expression	1
	Calculation of height of final image	3

a) Magnifying power is the ratio of the angle subtended at the eye by the image to the angle subtended at the unaided eye by the object. 1

Expression

$$m = \beta/\alpha = f_o/f_e$$

$$\text{or } m = f_o/f_e \left(1 + \frac{f_e}{D}\right) \quad 1$$

[Award 1 mark if student writes expression with -ve sign]

b) Using, the lens equation for objective lens, : 1

$$\begin{aligned} \frac{1}{f_o} &= \frac{1}{v_o} - \frac{1}{u_o} \\ \Rightarrow \frac{1}{150} &= \frac{1}{v_o} - \frac{1}{-3 \times 10^5} \end{aligned}$$

$$\Rightarrow \frac{1}{v_o} = \frac{1}{150} - \frac{1}{-3 \times 10^5} = \frac{2000-1}{3 \times 10^5} \quad \frac{1}{2}$$

$$\Rightarrow v_o = \frac{-3 \times 10^5}{1999} \text{ cm}$$

$$\approx 150 \text{ cm}$$

Hence, magnification due to the objective lens

$$m_o = \frac{v_o}{u_o} = \frac{150 \times 10^{-2} m}{3000 m} \quad \frac{1}{2}$$

$$\approx \frac{10^{-2}}{20} = .05 \times 10^{-2}$$

Using lens formula for eyepiece

$$\begin{aligned} \frac{1}{f_e} &= \frac{1}{v_e} - \frac{1}{u_e} \\ \Rightarrow \frac{1}{5} &= \frac{1}{-25} - \frac{1}{u_e} \\ \Rightarrow \frac{1}{u_e} &= \frac{1}{-25} - \frac{1}{5} = \frac{-1-5}{25} \\ \Rightarrow u_e &= \frac{-25}{6} \text{ cm} \end{aligned}$$

$$\therefore \text{Magnification due to eyepiece } m_e = \frac{-25}{\frac{-25}{6}} = 6 \quad \frac{1}{2}$$

Hence, total magnification  $\Rightarrow m = m_e \times m_o$

$$m = 6 \times 5 \times 10^{-4} = 30 \times 10^{-4}$$

Hence, size of final image

$$= 30 \times 10^{-4} \times 100 \text{ m}$$

$$= 30 \text{ cm}$$

1/2

5

(Award full marks for alternative method)

**OR**

Difference in working of telescope and microscope	2
Finding position of object	3

Working differences:

- Objective of a telescope forms the image of a very far off object at, or within, the focus of its eyepiece. The microscope does the same for a small object kept just beyond the focus of its objective.
- The final image formed by a telescope is magnified relative to its size as seen by the unaided eye while the final image formed by a microscope is magnified relative to its absolute size.
- The objective of a telescope has large focal length & large aperture while the corresponding for a microscope have very small values.

Give full credit if any two differences are written.

2

Telescope	Microscope
1. Resolving power should be higher for certain magnification.	1. Resolving power is not so large but the magnification should be higher.
2. Focal length of objective should be kept larger while eyepiece focal length should be small for better magnification.	2. Both objective and eye piece should have less focal length for better magnification.
3. Objective should be of large aperture.	3. Eye piece should be of large aperture.

1/2

1/2

4. Distance between objective and eye piece is adjusted to focus the object at infinity.	4. Distance between objective and eye piece is fixed, for focusing an object the distance of the objective is changed.	1/2
------------------------------------------------------------------------------------------	------------------------------------------------------------------------------------------------------------------------	-----

[Alternatively: Award these two marks if the student writes any two of the following differences.] 1

Given :  $f_o = 1.25\text{cm}$

$$f_e = 5\text{cm}$$

Angular magnification  $m = 30$

Now,  $m = m_e \times m_o$

In normal adjustment, angular magnification of eyepiece

$$m_e = \frac{d}{f_e} = + \frac{25}{5} = 5$$

Hence,  $m_o = 6$

But  $m_o = \frac{v_o}{u_o} \Rightarrow -6 = \frac{v_o}{u_o}$  1/2

$$\Rightarrow v_o = -6 u_o$$

Applying lens equation to the objective lens :

$$\frac{1}{f_o} = \frac{1}{v_o} - \frac{1}{u_o}$$
 1/2

$$\frac{1}{1.25} = \frac{1}{-6u_o} - \frac{1}{u_o}$$
 1/2

$$\frac{1}{1.25} = \frac{-1-6}{6u_o}$$

$$6 u_o = 1.25 \times (-7)$$

$$u_o = \frac{-1.25 \times 7}{6} \text{cm}$$

$$= -1.46 \text{ cm}$$
 1/2

5

30.	Circuit of CE transistor amplifier	2
	Working	1
	Derivation of voltage gain expression	1½
	Significance of negative sign	½

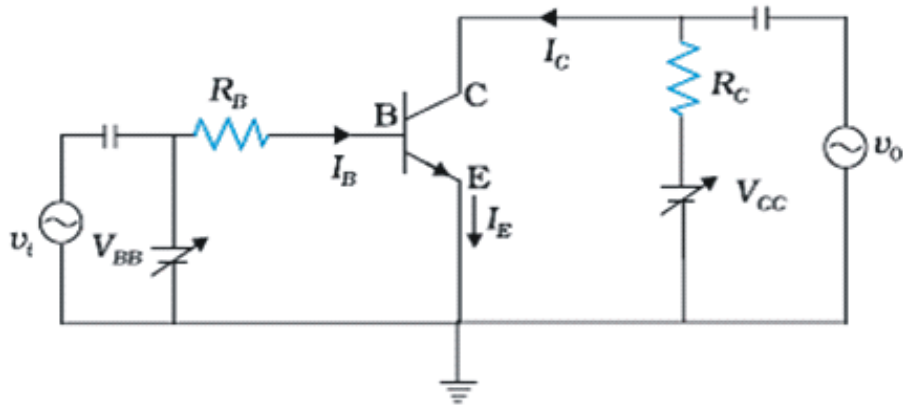

2

When an ac input signal  $v_i$  is superimposed on the bias  $v_{BB}$ , the output, which is measured between collector and ground, increases.

1

$$v_{CC} = v_{CE} + I_C R_L$$

$$v_{BB} = v_{BE} + I_B R_B$$

When  $v_i$  is not zero, we have

½

$$v_{BE} + v_i = v_{BE} + I_B R_B + \Delta I_B (R_B + R_i)$$

$$\Rightarrow v_i = \Delta I_B (R_B + R_i)$$

½

$$v_i = r \Delta I_B$$

Change in  $I_B$  causes a change in  $I_C$

$$\text{Hence, } \beta_{ac} = \frac{\Delta I_C}{\Delta I_B} = \frac{I_C}{I_B}$$

$$\text{As } \Delta V_{CC} = \Delta V_{CE} + R_L \Delta I_C = 0$$

$$\Rightarrow \Delta V_{CE} = -R_L \Delta I_C$$

$$\Rightarrow V_o = -R_L \Delta I_C$$

$$= \beta_{ac} \Delta I_B R_L$$

½

$\Rightarrow$  voltage gain of the amplifier

$$A_V = \frac{V_o}{v_i} = \frac{\Delta V_{CE}}{r \Delta I_B} = \frac{-\beta_{ac} \Delta I_B R_L}{r \Delta I_B}$$

$$= -\beta_{ac} \frac{R_L}{r}$$



Negative sign in the expression shows that output voltage and input voltage have phase difference of  $\pi$ . 1/2

[Alternatively

(Also accept this derivation for voltage gain expression)

$$A_v = \frac{\Delta V_{CE}}{\Delta V_{BE}} = \frac{-\Delta I_C R_L}{\Delta I_B R_i} \quad \text{1/2}$$

But current gain

$$b_{ac} = \frac{-\Delta I_C}{\Delta I_B} \quad \text{1/2}$$

$$\Rightarrow A_v = -\beta_{ac} \times \left[ \frac{R_L}{R_i} \right] \quad \text{1/2}$$

5

**OR**

(a)	Circuit diagram	1
	Working	1
	Output and input waveform	1/2 + 1/2
(b)	Output waveforms of OR and NAND gates	1 + 1

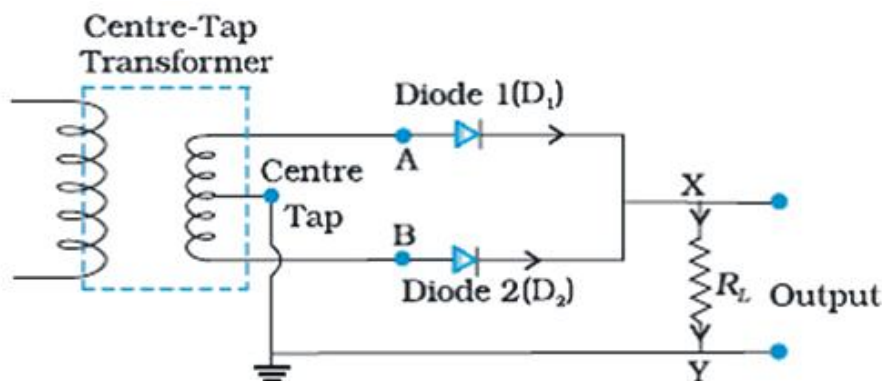

1

During first half cycle:

A is positive w.r.t centre tap but B is negative, hence only diode  $D_1$  conducts and current flows through the load in the sense X to Y. 1/2

During the second half cycle:

B is positive w.r.t centre tap but A is negative hence only diode  $D_2$  conducts and again send currents through load from X and Y.

$\frac{1}{2}$

$\therefore$  Current through the load, in both the halves of input, is unidirectional.

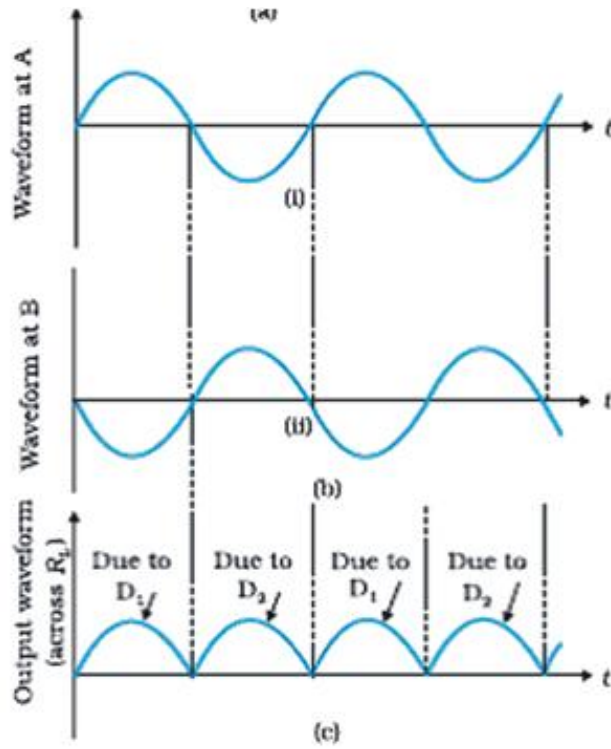

$\frac{1}{2}$

$\frac{1}{2}$

(b)

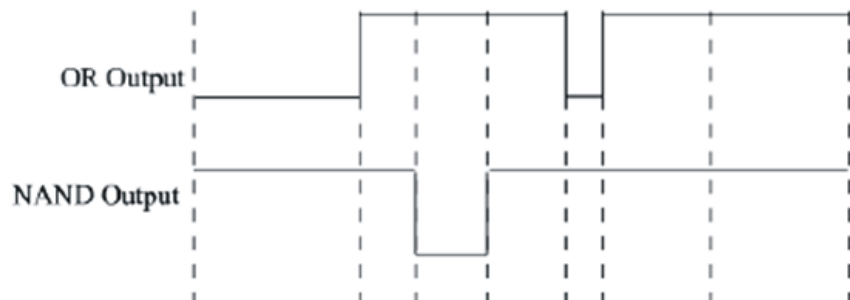

1

1

5

QUESTION PAPER CODE 55/1

Q. No.	Expected Answer/value Points	Marks	Total Marks
1.	Manganin If student only writes ( $\rho_m > \rho_c$ ) award ½ mark [If only the formula, $\rho/A = \text{constant}$ , is given award ½ mark.]	1	1
2.	$\vec{E}$ is perpendicular to $\vec{B}$ $\vec{E}$ and $\vec{B}$ are both perpendicular to the direction of propagation of wave. [Note: Award 1 mark if student writes that $\vec{E}$ & $\vec{B}$ are perpendicular to each other and to the direction of propagation of wave / all are perpendicular to one another / the directions are shown diagrammatically with proper labelling]	½ ½	1
3.	No change  ( If only $\theta = \lambda/d$ or $x/d$ is written, award ½ mark )	1	1
4.	Clock wise in both coils / Direction of Current is from $\mathbf{P} \rightarrow \mathbf{Q}$ and $\mathbf{C} \rightarrow \mathbf{D}$ or any other correct answer.	½ + ½	1
5.	Velocity of light is minimum in medium 'A'.  (If student writes only the formula for absolute refractive index of a medium as $\mu = \sin i / \sin r = c/v$ - Award ½ mark )	1	1
6.	Electron As $\lambda \propto \frac{1}{\sqrt{m}}$ (for same Kinetic energy)	½ ½	1
7.	Any two of the following: 1. Low Coercivity / Low Retentivity 2. Low hysteresis loss 3. High Magnetic Susceptibility / High Permeability 4. High resistivity	½ + ½	1
8.	$\phi_e = q / 6\epsilon_0$  [If student writes $\phi_e = \phi_{\text{net}} / 6$ award ½ Mark;  or $\phi_{\text{net}} = q / \epsilon_0$ award ½ mark.]	1	1

9.

Formula	1/2
Calculation of Potential Difference	1/2
Value & Explanation	1

Since  $E = -dV/dr$

$$E = (V_C - V_A)/4$$

Therefore,  $V_A - V_C = -4E$

At Point C, potential is more

Electric field is in the direction in which the potential decreases.

[Note:

- (i) Even if student writes the correct values of potential difference directly award 1 mark.
- (ii) Give full credit for any other correct method.]

1/2

1/2

1/2

1/2

2

10

Explanation of Net Force / Diagrammatically	1
Expression for Work done	1

(i)

$$\vec{F}_1 = +q\vec{E} \text{ and } \vec{F}_2 = -q\vec{E}$$

$$\vec{F}_{net} = \vec{F}_1 + \vec{F}_2$$

$$\therefore F_{net} = 0$$

1

Alternatively,

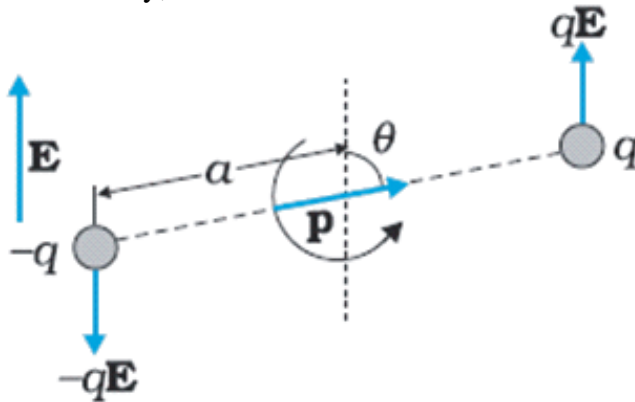

$$\therefore F_{net} = 0$$

(ii)

$$W = EP (\cos \theta_1 - \cos \theta_2)$$

$$W = 2EP$$

1/2

1/2

2

11

Principle	1
Explanation	1

A transformer is based on principle of mutual induction which states that due to continuous change in the current in the primary coil, an emf gets induced across the secondary coil.

1

Electric power generated at the power station, is stepped up to very high voltages by means of a step-up transformer and transmitted to a distant place. At receiving end, it is stepped down by a step down transformer.

1

**Alternatively**

[If student explains, transmission of electric energy diagrammatically with proper labeling or any other alternative method award 1 mark.]

2

12

Yes	½
Explanation	1
Expression	½

Yes, ammeter will show a momentary deflection.

½

The momentary deflection is due to the flow of electrons in the circuit during the charging process. During the charging process the electric field between the capacitor plates is changing and hence a displacement current flows in the gap. Hence we can say that there is a continuity of current in the circuit.

½

Expression  $I_d = \epsilon_0 \frac{d\phi}{dt}$

½

2

13

Ray diagram	1
Effect on the position and intensity of image	½ + ½

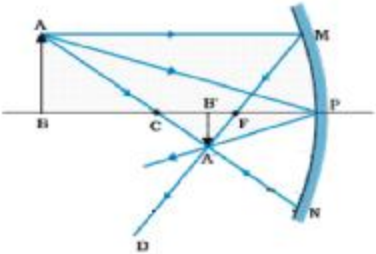

1

(deduct ½ mark if arrows are not shown)

- i) Position of image will remain same / unchanged
- ii) Intensity of image will decrease.

½  
½

2

14

Labelled Ray diagram	1
Two advantages	½ + ½

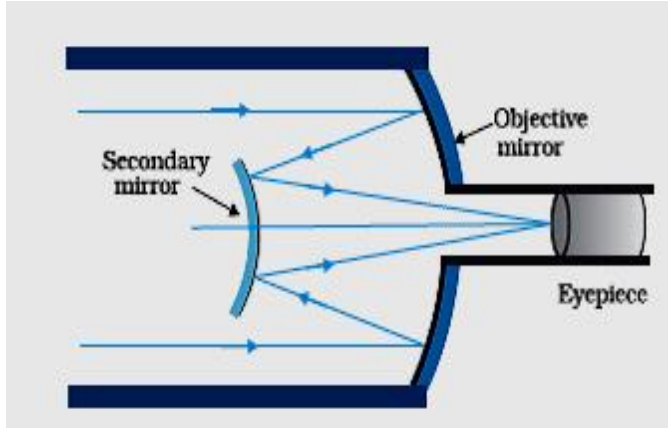

1

[Note: Also accept the ray diagram, if the student draws Newtonian telescope in lieu of Cassegrainian telescope]

- i) Image formed is brighter
  - ii) Image is free from chromatic aberration
  - ii) Image is free from spherical aberration
  - iv) Higher resolving power
  - v) Mechanical advantage in mounting
- (Any two)

½ + ½

2

15

Circuit diagram	1
Explanation	1

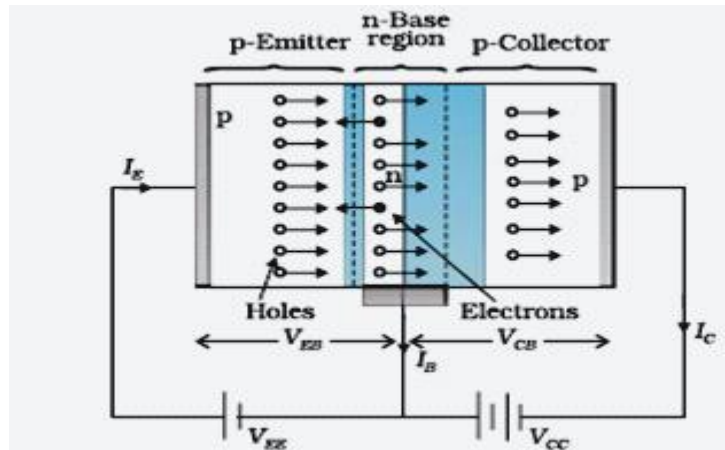

1

[Even if student draws any other relevant suitable diagram, award this mark.]

The heavily doped emitter has a high concentration of majority carriers, which are the holes in a p-n-p transistor. These majority carriers enter the base region in large numbers. As the base is thin and lightly doped, the majority carriers (holes), entering the base region from emitter, swamp the small number of electrons there and, as the collector is reverse biased, these holes can easily cross the junction and enter the collector.

1

[Note: If the student attempts to answer the question by considering the circuit for CE configuration award 1 mark]

2

16

Identification of boxes X and Y	$\frac{1}{2} + \frac{1}{2}$
Function	$\frac{1}{2} + \frac{1}{2}$

X = Intermediate frequency (IF) stage

$\frac{1}{2}$

Y = Amplifier / Power Amplifier

$\frac{1}{2}$

IF Stage : IF stage changes the carrier frequency to a lower frequency

$\frac{1}{2}$

Amplifier : Increases the strength of signals

$\frac{1}{2}$

2

17

i. Calculation of Resistance	1
ii. Calculation of rms current	1

(i)  $P = V^2/R$   $\frac{1}{2}$   
 $100 = \frac{(220)^2}{R} \Rightarrow R = \frac{220 \times 220}{100} = 484 \Omega$   $\frac{1}{2}$

(ii)  $i_{rms} = \frac{V_{rms}}{R}$  or  $\frac{P}{V_{rms}}$   $\frac{1}{2}$

$= \frac{220}{484}$  or  $\frac{100}{220} = 0.45 \text{ A}$   $\frac{1}{2}$

**OR**

i) Calculation of frequency	1
ii) Calculation of rms current	1

a)  $2\pi v = 314 \text{ rad s}^{-1}$   $\frac{1}{2}$   
 $\Rightarrow v = 50 \text{ Hz}$   $\frac{1}{2}$

b)  $i_{rms} = \frac{V_{rms}}{R}$  where  $V_{rms} = \frac{V}{\sqrt{2}}$   $\frac{1}{2}$   
 $= \frac{140}{\sqrt{2} \times 30} = 1.98 \text{ A} \approx 2 \text{ A}$   $\frac{1}{2}$

2

18.

Determination of the number of turns	1/2
Formula for magnetic moment	1/2
Calculation	1

We have:

$$N_1 \cdot 2\pi R = N_2 \cdot 2\pi(R/2) \quad \frac{1}{2}$$

$$\therefore N_2 = 2N_1$$

Magnetic Moment of a coil  $M = NAI$  1/2

For the coil of radius 'R'

$$M_1 = N_1 I A_1 = N_1 I \pi R^2$$

For the coil of radius R/2

$$M_2 = N_2 I A_2 = 2N_1 I \pi R^2 / 4 = N_1 I \pi R^2 / 2 \quad \frac{1}{2}$$

$$\Rightarrow M_2 : M_1 = 1 : 2 \quad \frac{1}{2}$$

[Alternatively,  $M_1 : M_2 = 2 : 1$ ] 2

19

Derivation of energy stored in capacitor	2
Effect on energy stored & electric field	1/2 + 1/2

Potential difference between the plates of capacitor 1/2

$$V = q / C$$

Work done to add additional charge dq on the capacitor

$$dw = V \times dq \quad \frac{1}{2}$$

$$= (q/C) \times dq$$

∴ Total energy stored in the capacitor

$$U = \int dw = \int_0^Q \frac{q}{C} dq = \frac{1}{2} \frac{Q^2}{C} \quad 1$$

When battery is disconnected

i) Energy stored will be decreased or energy stored = 1/K times the initial energy 1/2ii) Electric field would decrease 1/2  
or  $E' = E/K$ 

Alternatively, if a student attempts to answer by keeping the battery connected, then

(i) Energy stored will increase or become K times the initial energy. 1/2(ii) Electric field will not change 1/2

3



20.

Calculation of the unknown resistance	2
Calculation of potential difference	1

$$R_{BCD} = 15\Omega \quad \frac{1}{2}$$

$$\frac{1}{R_{BE}} = \frac{1}{15} + \frac{1}{10} + \frac{1}{30}$$

$$= \frac{2+3+1}{30}$$

$$R_{BE} = 5 \Omega \quad \frac{1}{2}$$

$$(15+5+R) \times 0.2 = 8-3=5 \quad \frac{1}{2}$$

$$(20+R) = 25$$

$$R = 5 \Omega \quad \frac{1}{2}$$

$$\therefore V_{BE} = IR_{BE} \quad \frac{1}{2}$$

$$= 0.2 \times 5 = 1.0 \text{ V} \quad \frac{1}{2} \quad 3$$

21

Distance between $L_1$ and $L_2$	2
Distance between $L_2$ and $L_3$	1

For lens  $L_1$

$$\frac{1}{f_1} = \frac{1}{v_1} - \frac{1}{u_1} \quad \frac{1}{2}$$

$$\frac{1}{20} = \frac{1}{v_1} - \frac{1}{-40} \Rightarrow v_1 = 40 \text{ cm} \quad \frac{1}{2}$$

For  $L_3$

$$\frac{1}{f_3} = \frac{1}{v_3} - \frac{1}{u_3}$$

$$u_3 = ?, f_3 = +20 \text{ cm}, v_3 = 20 \text{ cm}$$

$$\frac{1}{20} = \frac{1}{20} + \frac{1}{u_3}$$

$$u_3 = \infty \quad \frac{1}{2}$$

It shows that  $L_2$  must render the rays parallel to the common axis. It means that the image ( $I_1$ ), formed by  $L_1$ , must be at a distance of 20 cm from  $L_2$  ( at the focus of  $L_2$  )

Therefore, distance between  $L_1$  and  $L_2$  ( $=40+20$ ) = 60 cm and distance between  $L_2$  and  $L_3$  can have any value.

$\frac{1}{2}$   
1

[Note: Award full 3 marks to the student who correctly calculates the distance between  $L_1$  and  $L_2$  only. If the student draws the ray diagram correctly, award 1  $\frac{1}{2}$  marks]

3

22

Definitions	1 + 1
Explanation	1

Cut – off voltage : The minimum negative potential ( $V_0$ ) applied to the plate or anode (A) for which the photoelectric current just becomes zero,

1

Threshold frequency: The minimum frequency of incident radiation which is required to have photo electrons emitted from a given metal surface.

1

As per Einstein's photoelectric equation

$$eV_0 = h\nu - h\nu_0; \text{ for } \nu > \nu_0$$

$\frac{1}{2}$

$$V_0 = \frac{h}{e} (\nu - \nu_0)$$

$\frac{1}{2}$

Hence the intercept, on the  $\nu$ - axis, gives  $\nu_0$ . (one can read  $V_0$ , for any  $\nu$ , from the graph)

[Note: Award 1 mark when the student just gives the result for the threshold frequency]

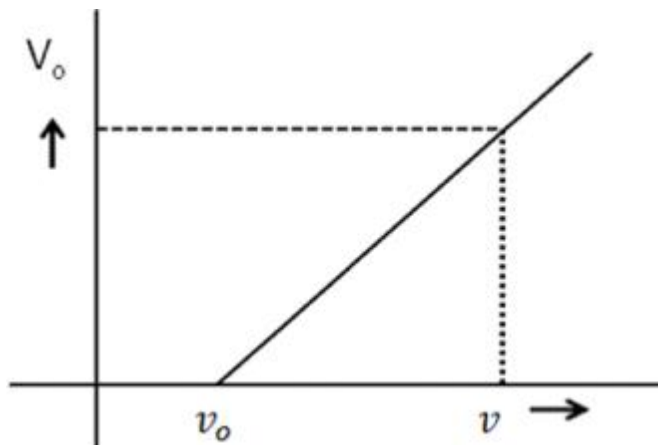

3

23

Phasor Diagram	1
Determination of impedance of LCR	1
Graph and justification	1/2 + 1/2

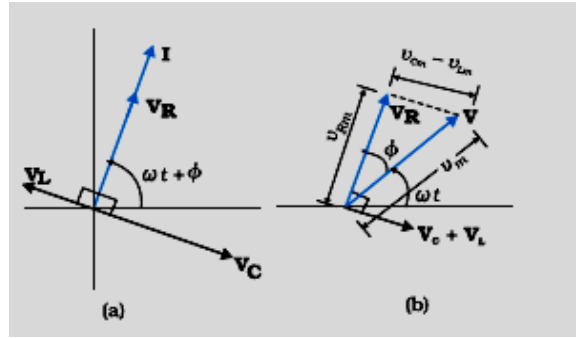

1

Resultant potential across LCR

$$V^2 = V_R^2 + (V_L - V_C)^2$$

$$V_R = iR, V_L = iX_L, V_C = iX_C$$

On solving \_\_\_\_\_

$$Z = \sqrt{R^2 + (X_L - X_C)^2}$$

1/2

1/2

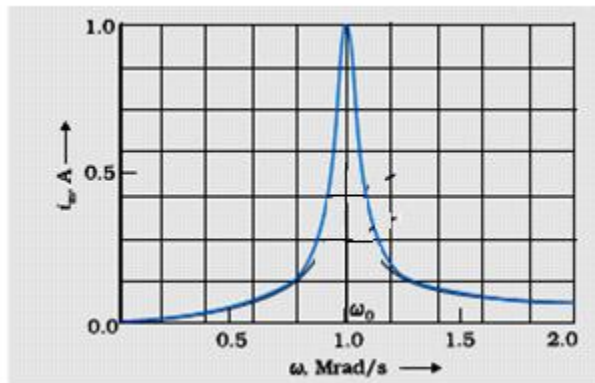

1/2

With increase in  $\omega$ , current first increases (upto  $\omega_0$ ) and then decreases

1/2

3

24

Three Modes of Transmission	1/2 + 1/2 + 1/2
Diagram	1
Explanation	1/2

(i) Ground wave or surface wave propagation

1/2

(ii) Sky wave propagation or ionospheric propagation

1/2

(iii) Space wave propagation / Line of sight propagation

1/2

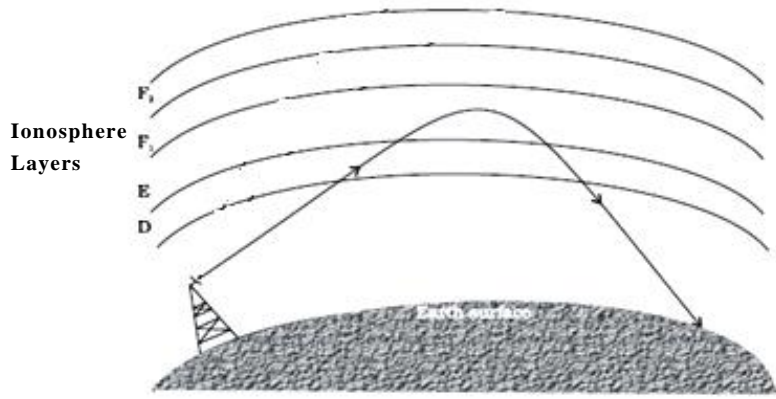

1

When radio waves (frequency range 3MHz to 30MHz), emitted from the transmitting antenna, reach the receiving antenna after reflection from the ionosphere which acts as a reflector for radio waves the corresponding mode of propagation is known as sky wave propagation.

1/2

3

25

Graph	1
Marking of force regions	1/2 + 1/2
Two characteristics features	1/2 + 1/2

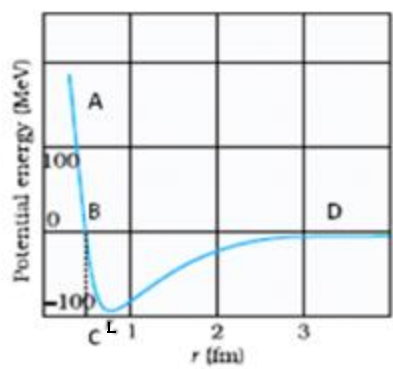

1

For  $r < OB$ , repulsive  
 For  $r > OB$  force is attractive  
 Nuclear forces are

1/2

1/2

- i) very strong
  - ii) charge independent
  - iii) show saturation
  - iv) spin dependent
- (Any two)

1/2

1/2

3

Formula	1
Calculation of $r_0$	1 ½
Effect on $r_0$	½

$$\frac{(Ze)(2e)}{4\pi\epsilon_0(r_0)} = K$$

$$r_0 = \frac{2Ze^2}{4\pi\epsilon_0(K)} \quad 1$$

$$r_0 = \frac{9 \times 10^9 \times 2 \times 80 \times (1.6 \times 10^{-19})^2}{8 \times 10^6 \times (1.6 \times 10^{-19})} \text{m} \quad \frac{1}{2}$$

$$= \frac{18 \times 1.6 \times 10^{-10} \times 80}{8 \times 10^6} \quad \frac{1}{2}$$

$$= 2.88 \times 10^{-14} \text{m} \quad \frac{1}{2}$$

$$r_0 \propto \frac{1}{KE} \quad 3$$

If KE becomes twice then  $r_0' = \frac{r_0}{2}$   
 i.e. distance of closest approach becomes half.  $\frac{1}{2}$

**OR**

Formula	1
Calculation of $\lambda$	1
Identification of series	1

$$hv = \frac{hc}{\lambda} = (E_2 - E_1) \quad \frac{1}{2}$$

$$\text{Or } \lambda = \frac{hc}{(E_2 - E_1)} \quad \frac{1}{2}$$

$$\therefore \lambda = \left[ \frac{6.63 \times 10^{-34} \times 3 \times 10^8}{[-0.85 - (-3.4)] \times 1.6 \times 10^{-19}} \right] \text{m} \quad \frac{1}{2}$$

$$= 4.87 \times 10^{-7} \text{m} \quad \frac{1}{2}$$

Balmer series 1

**[Note:**

If the student identifies the level of energy - 3.4 eV as n=2 level but does not write 'Balmer Series', award ½ mark for the last part of the question. ]

3

27.

Definition	1
Relation	1/2
Deducing the expression for resistivity	1 1/2

Relaxation time ( $\tau$ ): The average time interval between two successive collisions. For the free electrons drifting within a conductor (due to the action of the applied electric field), is called relaxation time. 1

Relation 1/2  
 $v_d = (-e E \tau) / m$

Since  $i = -n e A v_d$  1/2  
 $= n e^2 A \tau V / m l$  1/2  
 $\therefore V / i = m l / (n e^2 A \tau) = \rho l / A$  1/2  
 $\therefore \rho = m / (n e^2 \tau)$  1/2

3

28.

a) Diagram	1/2
Equation for path difference	1 1/2
Condition for constructive interference	1/2
Condition for destructive interference	1/2
b) Calculation of least distance	2

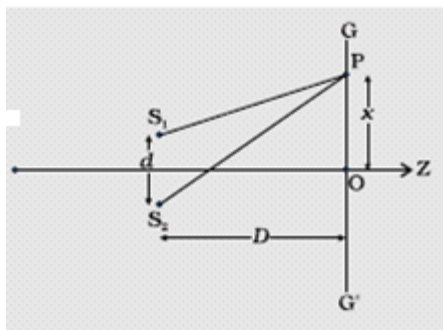

1/2

(a) We have

$$(S_2P)^2 - (S_1P)^2 = \left[ D^2 + \left( x + \frac{d}{2} \right)^2 \right] - \left[ D^2 + \left( x - \frac{d}{2} \right)^2 \right] \quad 1$$

$$\therefore S_2P - S_1P = \frac{2xd}{S_2P + S_1P} \approx \frac{2xd}{2D} = \frac{xd}{D} \quad 1/2$$

For constructive interference

$$S_2P - S_1P = n \lambda \quad 1/2$$

For destructive interference

$$S_2P - S_1P = (n + 1) \lambda / 2 \quad 1/2$$

where  $n = 0, 1, 2, \dots$

**Alternatively,**

$$\begin{aligned}
 y_1 &= a \cos \omega t && \\
 y_2 &= a \cos (\omega t + \phi) && \frac{1}{2} \\
 y &= y_1 + y_2 && \\
 &= a \{ \cos \omega t + \cos (\omega t + \phi) \} && \\
 &= 2a \cos \frac{\phi}{2} \cos (\omega t + \frac{\phi}{2}) && \frac{1}{2} \\
 \therefore I &= 4 I_0 \cos^2 \frac{\phi}{2} &&
 \end{aligned}$$

Condition for constructive interference 1

$$\phi = 0, \pm\pi, \pm2\pi, \pm4\pi, \dots \text{ or } \phi = \pm 2n\pi \quad (n = 0, 1, 2, 3, \dots)$$

Condition for destructive interference

$$\phi = \pm\pi, \pm3\pi, \pm5\pi, \dots \text{ or } \phi = \pm (2n + 1)\pi \quad (n = 0, 1, 2, 3, \dots) \quad 1$$

**b) The two bright fringes will coincide when** 1/2

$$m \lambda_1 = (m+1) \lambda_2 \quad \frac{1}{2}$$

$$m \cdot 800 \times 10^{-9} = (m+1) 600 \times 10^{-9}$$

$$\therefore m = 3 \quad \frac{1}{2}$$

$$X_m = (mD\lambda_1)/d \quad \frac{1}{2}$$

$$= (3 \times 1.4 \times 800 \times 10^{-9}) / (0.28 \times 10^{-3}) \text{m} \quad \frac{1}{2}$$

$$= 12 \times 10^{-3} \text{mm}$$

**OR**

a) Explanation/ Diagram	1
Diagram	1
Explanation	1
b) Finding the orientation of the third polaroid	2

a) When unpolarised light falls on a polaroid, it lets only those of its electric vectors that are oscillating along a direction perpendicular to its aligned molecules to pass through it. The incident light thus gets linearly polarised

**Alternatively,**

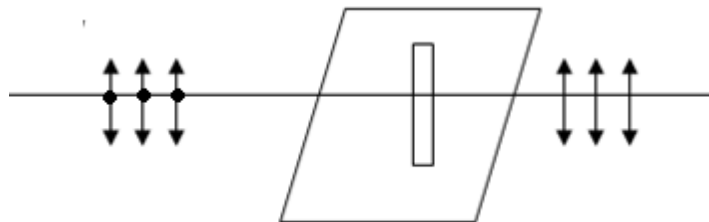

1

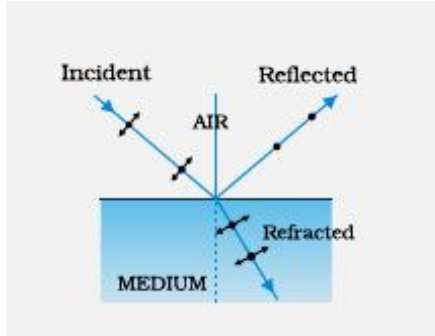

1

Whenever unpolarised light is incident on a transparent surface, the reflected light gets partially or completely polarized / the reflected light gets completely polarized when the reflected and refracted light are perpendicular to each other.

1

b) Let  $\theta$  be the angle between the pass axis of A and C

$\frac{1}{2}$

Intensity of light passing through A =  $I_0/2$

Intensity of light passing through C =  $(I_0/2)\cos^2 \theta$

Intensity of light passing through B =  $(I_0/2)\cos^2 \theta \cdot [\cos^2 (90-\theta)]$

$\frac{1}{2}$

$$= (I_0/2) \cdot (\cos \theta \cdot \sin \theta)^2 = I_0/8 \text{ (Given)}$$

$\frac{1}{2}$

$$\therefore \sin 2\theta = 1$$

$$2\theta = 90^\circ$$

The third Polaroid is placed at  $\theta = 45^\circ$

$\frac{1}{2}$

5

29	a)	Diagram	1
		Two processes	$\frac{1}{2} + \frac{1}{2}$
		Description of processes	$\frac{1}{2} + \frac{1}{2}$
	b)	Name of Device	$\frac{1}{2}$
		Circuit diagram	1
		Working	$\frac{1}{2}$

(a)

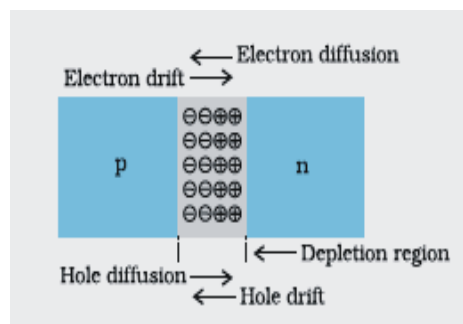

1



The two processes are

i. Diffusion 1/2

ii. Drift 1/2

Diffusion : Holes diffuse from p – side to n- side (p → n) and electrons diffuse from n– side to p- side (n → p)

Drift : The motion of charge carriers, due to the applied 1/2

electric field ( $\vec{E}$ ) which results in drifting of holes 1/2

along  $\vec{E}$  and of electrons opposite to that of 3

electric field ( $\vec{E}$ ), 1/2

a) Name of device : Zener Diode

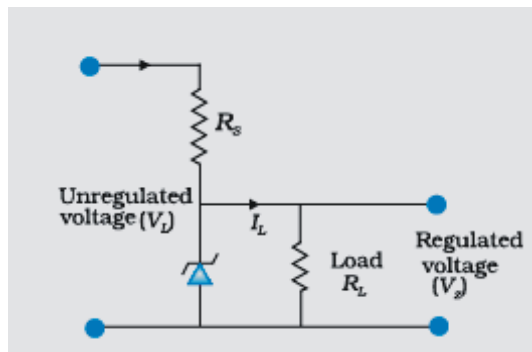

1

Working :

Any increase / decrease in the input voltage results in an increase / decrease of the voltage drop across  $R_s$  without any change in voltage across the Zener diode. Thus Zener diode acts as voltage regulator

1/2

5

**OR**

a) Principle of oscillator	1/2
Circuit Diagram	1 1/2
Working	1
b) Identification	1
Truth Table	1

1/2

a) Principle : A portion of the output power is returned back (feedback) to the input in phase with the starting power (This process is termed as positive feedback)

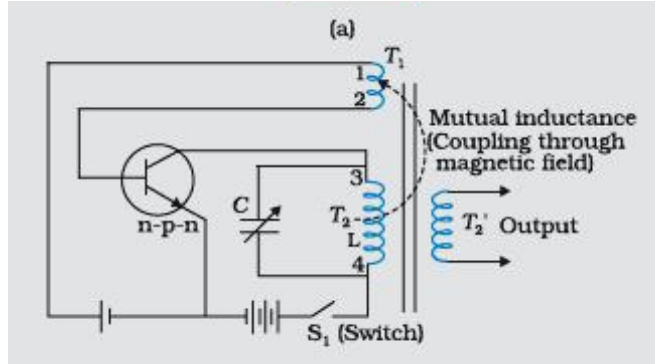

1½

Working:

As the switch  $S_1$  is put on, a surge of collector current flows in the transistor. This current flows through the coil  $T_2$ . The inductive coupling between coil  $T_2$  and coil  $T_1$  now causes a current to flow in the emitter circuit. As a result of this positive feedback, the emitter current also increases. When the current in  $T_2$  becomes saturated, it stops increasing. Now emitter current begins to fall and becomes minimum. The whole process keeps on repeating itself.

1

(If the student draws the block diagram with positive feedback then also award ½ mark for principle)

b) **AND Gate**

A	B	Y=A.B
0	0	0
0	1	0
1	0	0
1	1	1

1

(If student identifies the two given gates correctly, award ½ mark)

5

30.	(a) Expression for Force	1
	Condition for undeflected motion	1
(b)	Diagram	1
	Expression for torque	2

$$\vec{F} = q [\vec{v} + (\vec{B} \times \vec{v})]$$

1

Condition for undeflected motion

$$\begin{aligned}
 \vec{F} &= 0 \\
 \rightarrow q [\vec{E} + (\vec{v} \times \vec{B})] &= 0 && \frac{1}{2} \\
 \Rightarrow \vec{E} + \vec{v} \times \vec{B} &= 0 \\
 \Rightarrow \vec{E} &= -(\vec{v} \times \vec{B}) \\
 \text{or } \vec{E} &= \vec{B} \times \vec{v} && \text{or } E = B v \sin \theta \\
 & && = B v \text{ (when } \theta = 90^\circ) && \frac{1}{2}
 \end{aligned}$$

giving  $v = E/B$  when  $E, B$  and  $v$  are mutually perpendicular.

(b)

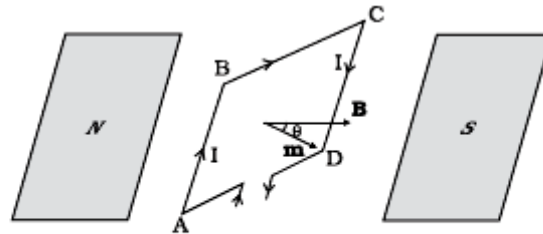

(a)

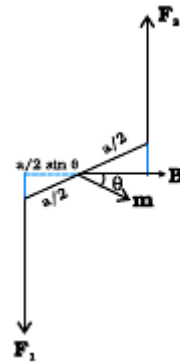

$$F_1 = F_2 = I b B \quad \frac{1}{2}$$

$$\vec{\tau} = F_1 \frac{a}{2} \sin \theta + F_2 \frac{a}{2} \sin \theta$$

$$= I a b B \sin \theta$$

$$= I A B \sin \theta \quad \frac{1}{2}$$

$$\text{But } \mathbf{m} = I \mathbf{A}$$

$$\therefore \tau = m B \sin \theta$$

$$\vec{\tau} = \vec{m} \times \vec{B}$$

Hence, The sense of  $\vec{\tau}$  is in the sense of  $\vec{m} \times \vec{B}$   $\frac{1}{2}$  5

**OR**

a)		
Conversion of galvanometer into voltmeter		1
Conversion of galvanometer into Ammeter		1
(b)		
Diagram & explanation		1 ½
Derivation of expression for force		1
Nature of force		½

- i. A galvanometer can be converted into a voltmeter by connecting a high resistance in series with its coil 1
- ii. A galvanometer can be converted into an ammeter by connecting a low resistance in parallel to its coil. 1

Alternatively,

[Give full credit to the student if the student shows the conversion of galvanometer to voltmeter and ammeter diagrammatically as follows:

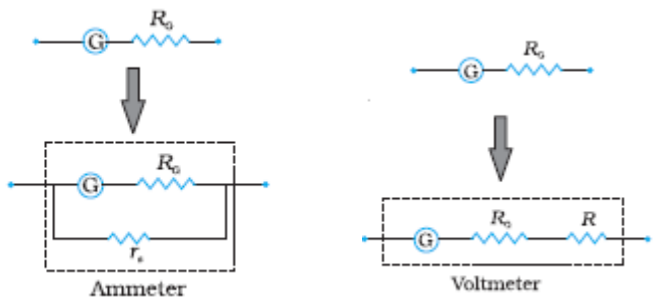

1

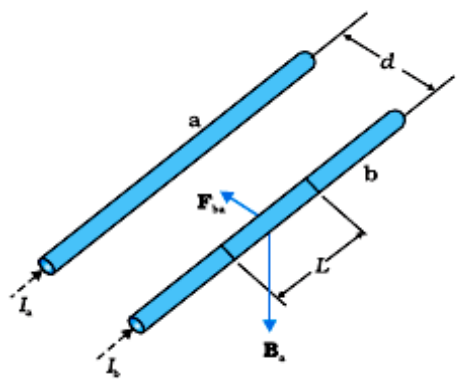

½

The magnetic field, due to wire – 1, at any point on the wire – 2, is directed normal to the direction of current flow in wire – 2.

Expression for force

$B_{21}$  = Magnetic field at wire – 2, due to a current  $I_1$  in

$$\text{wire – 1} = \frac{\mu_0 I_1}{2\pi r}$$

Force upon conductor carrying current due to magnetic field

$$\vec{F} = I(\vec{l} \times \vec{B}) \quad \frac{1}{2}$$

$$\therefore \text{Force, } F_{21} \text{ on a length } l \text{ of wire – 2} = I_2 \cdot l \cdot \frac{\mu_0 I_1}{2\pi r} \quad \frac{1}{2}$$

$$= \frac{\mu_0 I_1 I_2}{2\pi r} l \quad \frac{1}{2}$$

$$\text{Similarly, } F_{12} = \frac{\mu_0 I_1 I_2}{2\pi r} l \quad \frac{1}{2}$$

Nature

The force is repulsive for currents in opposite direction and attractive when currents flow in the same direction. 1/2

# CHEMISTRY (Theory)

*Time allowed : 3 hours*

*Maximum Marks : 70*

## **General Instructions:**

- (i) All questions are compulsory.
- (ii) Marks for each question are indicated against it.
- (iii) Question numbers 1 to 8 are very short-answer questions and carry 1 mark each.
- (iv) Question numbers 9 to 18 are short-answer questions and carry 2 marks each.
- (v) Question numbers 19 to 27 are also short-answer questions and carry 3 marks each.
- (vi) Question numbers 28 to 30 are long-answer questions and carry 5 marks each.
- (vii) Use Log Tables, if necessary, Use of calculators is **not** allowed.

## QUESTION PAPER CODE 56/1/1

1. What is meant by 'doping' in a semiconductor? 1
2. What is the role of graphite in the electrometallurgy of aluminium ? 1
3. Which one of  $\text{PCl}_4^+$  and  $\text{PCl}_4^-$  is not likely to exist and why? 1
4. Give the IUPAC name of the following compound. 1  
$$\begin{array}{c} \text{CH}_2 = \text{C} - \text{CH}_2\text{Br} \\ | \\ \text{CH}_3 \end{array}$$
5. Draw the structural formula of 2-methylpropan-2-ol molecule. 1
6. Arrange the following compounds in an increasing order of their reactivity in nucleophilic addition reactions: ethanal, propanal, propanone, butanone. 1

7. Arrange the following in the decreasing order of their basic strength in aqueous solutions: 1
- $\text{CH}_3\text{NH}_2$ ,  $(\text{CH}_3)_2\text{NH}$ ,  $(\text{CH}_3)_3\text{N}$  and  $\text{NH}_3$
8. Define the term, 'homopolymerisation' giving an example. 1
9. A 1.00 molal aqueous solution of trichloroacetic acid ( $\text{CCl}_3\text{COOH}$ ) is heated to its boiling point. The solution has the boiling point of  $100.18^\circ\text{C}$ . Determine the van't Hoff factor for trichloroacetic acid. ( $K_b$  for water =  $0.512\text{ K kg mol}^{-1}$ ) 2

**OR**

Define the following terms:

- (i) Mole fraction
  - (ii) Isotonic solutions
  - (iii) Van't Hoff factor
  - (iv) Ideal solution
10. What do you understand by the 'order of a reaction' ? Identify the reaction order from each of the following units of reaction rate constant:
- (i)  $\text{L}^{-1}\text{ mol s}^{-1}$
  - (ii)  $\text{L mol}^{-1}\text{ s}^{-1}$
11. Name the two groups into which phenomenon of catalysis can be divided. Give an example of each group with the chemical equation involved. 2
12. What is meant by coagulation of a colloidal solution? Describe briefly any three methods by which coagulation of lyophobic sols can be carried out. 2
13. Describe the principle involved in each of the following processes.
- (i) Mond process for refining of Nickel.
  - (ii) Column chromatography for purification of rare elements.
14. Explain the following giving an appropriate reason in each case. 2
- (i)  $\text{O}_2$  and  $\text{F}_2$  both stabilize higher oxidation states of metals but  $\text{O}_2$  exceeds  $\text{F}_2$  in doing so.
  - (ii) Structures of Xenon fluorides cannot be explained by Valence Bond approach.

15. Complete the following chemical equations: 2
- (i)  $\text{Cr}_2\text{O}_7^{2-} + \text{H}^+ + \text{I}^- \rightarrow$
- (ii)  $\text{MnO}_4^- + \text{NO}_2^- + \text{H}^+ \rightarrow$
16. What is meant by (i) peptide linkage (ii) biocatalysts? 2
17. Write any two reactions of glucose which cannot be explained by the open chain structure of glucose molecule. 2
18. Draw the structure of the monomer for each of the following polymers: 2
- (i) Nylon 6
- (ii) Polypropene
19. Tungsten crystallizes in body centred cubic unit cell. If the edge of the unit cell is 316.5 pm, what is the radius of tungsten atom? 2

**OR**

- Iron has a body centred cubic unit cell with a cell dimension of 286.65 pm. The density of iron is  $7.874 \text{ g cm}^{-3}$ . Use this information to calculate Avogadro's number. 3
- (At. mass of Fe = 55.845 u)
20. Calculate the amount of KCl which must be added to 1 kg of water so that the freezing point is depressed by 2K. ( $K_f$  for water =  $1.86 \text{ K kg mol}^{-1}$ ) 3
21. For the reaction

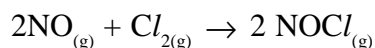

the following data were collected. All the measurements were taken at 263 K :

Experiment. No.	Initial [NO] (M)	Initial [ $\text{Cl}_2$ ] (M)	Initial rate of disappearance of $\text{Cl}_2$ (M/min)
1	0.15	0.15	0.60
2	0.15	0.30	1.20
3	0.30	0.15	2.40
4	0.25	0.25	?



- (a) Write the expression for rate law.
- (b) Calculate the value of rate constant and specify its units.
- (c) What is the initial rate of disappearance of  $Cl_2$  in exp. 4 ? 3
22. How would you account for the following? 3
- (i) Many of the transition elements are known to form interstitial compounds.
- (ii) The metallic radii of the third (5d) series of transition metals are virtually the same as those of the corresponding group members of the second (4d) series.
- (iii) Lanthanoids form primarily + 3 ions, while the actinoids usually have higher oxidation states in their compounds, + 4 or even + 6 being typical.
23. Give the formula of each of the following coordination entities:
- (i)  $Co^{3+}$  ion is bound to one  $Cl^-$ , one  $NH_3$  molecule and two bidentate ethylene diamine (en) molecules.
- (ii)  $Ni^{2+}$  ion is bound to two water molecules and two oxalate ions.
- Write the name and magnetic behaviour of each of the above coordination entities.
- (At. nos. Co = 27, Ni = 28) 3
24. Although chlorine is an electron withdrawing group, yet it is ortho-, para-directing in electrophilic aromatic substitution reactions. Explain why it is so ? 3
25. Draw the structure and name the product formed if the following alcohols are oxidized. Assume that an excess of oxidizing agent is used.
- (i)  $CH_3CH_2CH_2CH_2OH$
- (ii) 2-butenol
- (iii) 2-methyl-1-propanol 3
26. Write chemical equations for the following conversions: 3
- (i) Nitrobenzene to benzoic acid.
- (ii) Benzyl chloride to 2-phenylethanamine.
- (iii) Aniline to benzyl alcohol.

27. What are the following substances? Give one example of each one of them. 3
- (i) Tranquilizers
  - (ii) Food preservatives
  - (iii) Synthetic detergents

28. (a) What type of a battery is the lead storage battery? Write the anode and the cathode reactions and the overall reaction occurring in a lead storage battery when current is drawn from it.
- (b) In the button cell, widely used in watches, the following reaction takes place

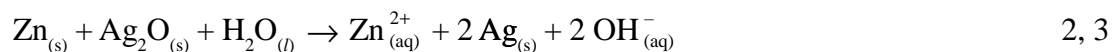

Determine  $E^\circ$  and  $\Delta G^\circ$  for the reaction.

(given:  $E^\circ_{\text{Ag}^+/\text{Ag}} = + 0.80\text{V}$ ,  $E^\circ_{\text{Zn}^{2+}/\text{Zn}} = - 0.76\text{V}$ )

**OR**

- (a) Define molar conductivity of a solution and explain how molar conductivity changes with change in concentration of solution for a weak and a strong electrolyte.
- (b) The resistance of a conductivity cell containing 0.001 M KCl solution at 298 K is 1500  $\Omega$ . What is the cell constant if the conductivity of 0.001 M KCl solution at 298 K is  $0.146 \times 10^{-3} \text{S cm}^{-1}$ ? 2, 3

29. (a) Complete the following chemical reaction equations:

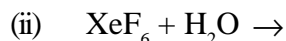
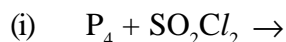

- (b) Predict the shape and the asked angle ( $90^\circ$  or more or less) in each of the following cases:

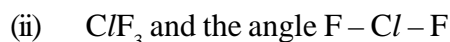
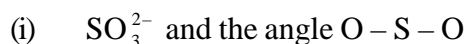

**OR**

(a) Complete the following chemical equations:

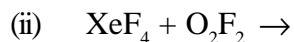
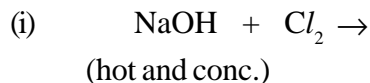

(b) Draw the structures of the following molecules:

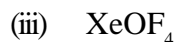
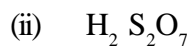

2, 3

30. (a) Illustrate the following name reactions giving suitable example in each case:

(i) Clemmensen reduction

(ii) Hell-Volhard-Zelinsky reaction

(b) How are the following conversions carried out?

(i) Ethylcyanide to ethanoic acid

(ii) Butan-1-ol to butanoic acid

(iii) Benzoic acid to m-bromobenzoic acid

2, 3

**OR**

(a) Illustrate the following reactions giving a suitable example for each.

(i) Cross aldol condensation

(ii) Decarboxylation

(b) Give simple tests to distinguish between the following pairs of compounds

(i) Pentan-2-one and Pentan-3-one

(ii) Benzaldehyde and Acetophenone

(iii) Phenol and Benzoic acid

2, 3

---

**QUESTION PAPER CODE 56/1**

1. How may the conductivity of an intrinsic semiconductor be increased? 1
2. Define 'peptization'. 1
3. How is copper extracted from a low grade ore of it ? 1
4. Which is a stronger reducing agent,  $\text{SbH}_3$  or  $\text{BiH}_3$ , and why? 1
5. What happens when bromine attacks  $\text{CH}_2 = \text{CH} - \text{CH}_2 - \text{C} \equiv \text{CH}$  ? 1
6. Write the IUPAC name of the following:

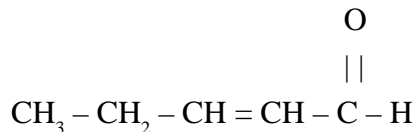

7. Write the structure of the product obtained when glucose is oxidised with nitric acid. 1
8. Differentiate between disinfectants and antiseptics. 1
9. Express the relation among cell constant, resistance of the solution in the cell and conductivity of the solution. How is molar conductivity of a solution related to its conductivity? 2

**OR**

- The molar conductivity of a 1.5 M solution of an electrolyte is found to be  $138.9 \text{ Scm}^2 \text{ mol}^{-1}$ . Calculate the conductivity of this solution. 2
10. A reaction is of second order with respect to a reactant. How is its rate affected if the concentration of the reactant is (i) doubled (ii) reduced to half? 2
  11. Which methods are usually employed for purifying the following metals: 2
    - (i) Nickel
    - (ii) Germanium

Mention the principle behind each one of them.

12. Explain the following facts giving appropriate reason in each case: 2
- (i)  $\text{NF}_3$  is an exothermic compound whereas  $\text{NCl}_3$  is not.
  - (ii) All the bonds in  $\text{SF}_4$  are not equivalent.
13. Complete the following chemical reaction equations: 2
- (i)  $\text{Cr}_2\text{O}_7^{2-} + \text{I}^- + \text{H}^+ \rightarrow$
  - (ii)  $\text{MnO}_4^- + \text{NO}_2^- + \text{H}^+ \rightarrow$
14. Explain the mechanism of acid catalysed hydration of an alkene to form corresponding alcohol. 2
15. Explain the following behaviours : 2
- (i) Alcohols are more soluble in water than the hydrocarbons of comparable molecular masses.
  - (ii) Ortho-nitrophenol is more acidic than ortho-methoxyphenol.
16. Describe the following giving the relevant chemical equation in each case: 2
- (i) Carbylamine reaction
  - (ii) Hofmann's bromamide reaction
17. Complete the following reaction equations: 2
- (i)  $\text{C}_6\text{H}_5\text{N}_2\text{Cl} + \text{H}_3\text{PO}_2 + \text{H}_2\text{O} \rightarrow$
  - (ii)  $\text{C}_6\text{H}_5\text{NH}_2 + \text{Br}_2 (\text{aq.}) \rightarrow$
18. What are food preservatives? Name two such substances. 2
19. Copper crystallises with face centred cubic unit cell. If the radius of copper atom is 127.8 pm, calculate the density of copper metal. 3
- (Atomic mass of Cu = 63.55 u and  
Avogadro's number  $N_A = 6.02 \times 10^{23} \text{ mol}^{-1}$ )

**OR**

- Iron has a body centred cubic unit cell with the cell dimension of 286.65 pm. Density of iron is  $7.87 \text{ g cm}^{-3}$ . Use this information to calculate Avogadro's number. (Atomic mass of Fe = 56.0 u) 3
20. The electrical resistance of a column of 0.05 M NaOH solution of diameter 1 cm and length 50 cm is  $5.55 \times 10^3 \text{ ohm}$ . Calculate its resistivity, conductivity and molar conductivity. 3
21. The reaction,  $\text{N}_2 (\text{g}) + \text{O}_2 (\text{g}) \rightleftharpoons 2 \text{NO} (\text{g})$  contributes to air pollution whenever a fuel is burnt in air at a high temperature. At 1500 K, equilibrium constant K for it is  $1.0 \times 10^{-5}$ . Suppose in a case  $[\text{N}_2] = 0.80 \text{ mol L}^{-1}$  and  $[\text{O}_2] = 0.20 \text{ mol L}^{-1}$  before any reaction occurs. Calculate the equilibrium concentrations of the reactants and the product after the mixture has been heated to 1500 K. 3
22. Explain the following terms giving a suitable example for each: 3
- (i) Aerosol
  - (ii) Emulsion
  - (iii) Micelle
23. How would you account for the following: 3
- (i) Among lanthanoids, Ln (III) compounds are predominant. However, occasionally in solutions or in solid compounds, +2 and +4 ions are also obtained.
  - (ii) The  $E_{\text{M}^{2+}/\text{M}}^{\circ}$  for copper is positive (0.34 V). Copper is the only metal in the first series of transition elements showing this behaviour.
  - (iii) The metallic radii of the third (5d) series of transition metals are nearly the same as those of the corresponding members of the second series.
24. Name the following coordination entities and draw the structures of their stereoisomers :
- (i)  $[\text{Co}(\text{en})_2 \text{Cl}_2]^+$  (en = ethan-1, 2-diamine)
  - (ii)  $[\text{Cr}(\text{C}_2\text{O}_4)_3]^{3-}$
  - (iii)  $[\text{Co}(\text{NH}_3)_3 \text{Cl}_3]$
- (Atomic numbers Cr = 24, Co = 27)

25. Answer the following questions: 3

- (i) What is meant by chirality of a compound? Give an example.
- (ii) Which one of the following compounds is more easily hydrolyzed by KOH and why?

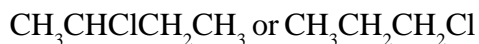

- (iii) Which one undergoes  $\text{S}_{\text{N}}2$  substitution reaction faster and why?

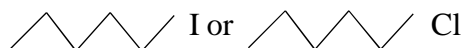

26. What is essentially the difference between  $\alpha$ -glucose and  $\beta$ -glucose? What is meant by pyranose structure of glucose?

27. Differentiate between thermoplastic and thermosetting polymers. Give one example of each. 3

28. (a) Define the following terms:

- (i) Mole fraction  
(ii) Ideal solution

- (b) 15.0 g of an unknown molecular material is dissolved in 450 g of water. The resulting solution freezes at  $-0.34^\circ\text{C}$ . What is the molar mass of the material? ( $K_f$  for water =  $1.86 \text{ K kg mol}^{-1}$ )

2, 3

**OR**

(a) Explain the following:

- (i) Henry's law about dissolution of a gas in a liquid  
(ii) Boiling point elevation constant for a solvent

- (b) A solution of glycerol ( $\text{C}_3\text{H}_8\text{O}_3$ ) in water was prepared by dissolving some glycerol in 500 g of water. This solution has a boiling point of  $100.42^\circ\text{C}$ . What mass of glycerol was dissolved to make this solution? ( $K_b$  for water =  $0.512 \text{ K kg mol}^{-1}$ )

2, 3

29. (a) Draw the molecular structures of the following compounds:

- (i)  $\text{N}_2\text{O}_5$   
(ii)  $\text{XeOF}_4$

- (b) Explain the following observations:
- (i) Sulphur has a greater tendency for catenation than oxygen.
  - (ii)  $\text{ICl}$  is more reactive than  $\text{I}_2$ .
  - (iii) Despite lower value of its electron gain enthalpy with negative sign, fluorine ( $\text{F}_2$ ) is a stronger oxidising agent than  $\text{Cl}_2$ .

2, 3

**OR**

- (a) Complete the following chemical equations:

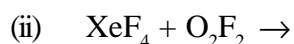

- (b) Explain the following observations:

(i) Phosphorus has greater tendency for catenation than nitrogen.

(ii) Oxygen is a gas but sulphur a solid.

(iii) The halogens are coloured. Why?

2, 3

30. (a) Write a suitable chemical equation to complete each of the following transformations:

(i) Butan-1-ol to butanoic acid

(ii) 4-Methylacetophenone to benzene-1,4-dicarboxylic acid

- (b) An organic compound with molecular formula  $\text{C}_9\text{H}_{10}\text{O}$  forms 2,4-DNP derivative, reduces Tollen's reagent and undergoes Cannizzaro's reaction. On vigorous oxidation it gives 1,2-benzenedicarboxylic acid. Identify the compound.

2, 3

**OR**

- (a) Give chemical tests to distinguish between

(i) Propanol and propanone

(ii) Benzaldehyde and acetophenone

- (b) Arrange the following compounds in an increasing order of their property as indicated:



- (i) Acetaldehyde, Acetone, Methyl tert-butyl ketone (reactivity towards HCN).
- (ii) Benzoic acid, 3,4-Dinitrobenzoic acid, 4-Methoxybenzoic acid (acid strength)
- (iii)  $\text{CH}_3\text{CH}_2\text{CH}(\text{Br})\text{COOH}$ ,  $\text{CH}_3\text{CH}(\text{Br})\text{CH}_2\text{COOH}$ ,  $(\text{CH}_3)_2\text{CHCOOH}$   
(acid strength)

2, 3

## Marking Scheme — Chemistry

### *General Instructions*

1. The Marking Scheme provides general guidelines to reduce subjectivity in the marking. The answers given in the Marking Scheme are suggested answers. The content is thus indicative. If a student has given any other answer which is different from the one given in the Marking Scheme, but conveys the same meaning, such answers should be given full weightage.
2. The Marking Scheme carries only suggested value point for the answers. These are only guidelines and do not constitute the complete answers. The students can have their own expression and if the expression is correct the marks will be awarded accordingly.
3. The Head-Examiners have to go through the first five answer-scripts evaluated by each evaluator to ensure that the evaluation has been carried out as per the instruction given in the marking scheme. The remaining answer scripts meant for evaluation shall be given only after ensuring that there is no significant variation in the marking of individual evaluators.
4. Evaluation is to be done as per instructions provided in the Marking Scheme. It should not be done according to one's own interpretation or any other consideration - Marking Scheme should be strictly adhered to and religiously followed.
5. If a question has parts, please award marks in the right hand side for each part. Marks awarded for different parts of the question should then be totalled up and written in the left hand margin and circled.
6. If a question does not have any parts, marks be awarded in the left-hand margin.
7. If a candidate has attempted an extra question, marks obtained in the question attempted first should be retained and the other answer should be scored out.
8. No Marks to be deducted for the cumulative effect of an error. It should be penalized only once.
9. A full scale of marks 0-70 has to be used. Please do not hesitate to award full marks if the answer deserves it.
10. Separate marking schemes for all the three sets have been provided.
11. As per orders of the Hon'ble Supreme Court. The candidates would now be permitted to obtain photocopy of the Answer book on request on payment of the prescribed fee. All examiners/Head Examiners are once again reminded that they must ensure that evaluation is carried out strictly as per value points for each answer as given in the Marking Scheme.

QUESTION PAPER CODE 56/1/1

**EXPECTED ANSWERS/VALUE POINTS**

- 1 Addition of a suitable impurity to the semi-conductor to increase its conductivity is called **Doping**. 1
- 2 Graphite acts as an Anode in the electro metallurgy of Aluminium. 1
- 3  $\text{PCl}_4^-$ , because P has 10 electrons which cannot be accommodated in  $\text{sp}^3$  hybrid orbitals. **(Note:ignore the reason)** 1
- 4 3-bromo-2-methyl propene 1
- 5 
$$\begin{array}{c} \text{OH} \\ | \\ \text{CH}_3 - \text{C} - \text{CH}_3 \\ | \\ \text{CH}_3 \end{array}$$
 1
- 6 Butanone < Propanone < Propanal < Ethanal 1
- 7  $(\text{CH}_3)_2\text{NH} > \text{CH}_3\text{NH}_2 > (\text{CH}_3)_3\text{N} > \text{NH}_3$  1
- 8 The polymer formed by the polymerization of a single/same monomeric species is known as **Homopolymerisation**.  
eg. Polythene/ PVC/ Polypropene or any other.  $\frac{1}{2}$ ,  $\frac{1}{2}$
- 9  $\Delta T_b = iK_b m$   
 $(100.18 - 100)^\circ\text{C} = i \times 0.512\text{K kg mol}^{-1} \times 1\text{m}$  1  
 $0.18\text{ K} = i \times 0.512\text{K kg mol}^{-1} \times 1\text{m}$   
 $i = 0.35$  1

**OR**

- (i) **Mole fraction** is the ratio of number of moles of one component to the total number of moles in a mixture **(or mathematical expression)**
- (ii) Two solutions having same osmotic pressure at a given temperature are called **Isotonic Solutions**.

- (iii) **Van't Hoff factor** is expressed as:
- $$i = \frac{\text{normal molar mass}}{\text{abnormal molar mass}}$$
- (or any other definition)
- (iv) The solution which obeys Raoult's law under all conditions is known as an ideal solution. 1/2 x 4=2
- 10 The sum of powers of the concentration of the reactants in the rate law expression is called the order of that chemical reaction /  $r = k[A]^x[B]^y$  1
- Order = x+y
- (i) zero order
- (ii) second order 1/2+1/2
- 11 **(any attempt to bring out the meaning /relevance of catalysis should be awarded full marks)** 2
- 12 The process of settling of colloidal particles is called coagulation or precipitation of the sol. 1/2
- (i) By Electrophoresis / The collidal particles move towards oppositely charged electrodes.
- (ii) By mixing two oppositely charged sols
- (iii) By addition of electrolytes / When excess of an electrolyte is added the coll-oidal particles are precipitated. 1/2 , 1/2 ,  
1/2
- (or any other correct method)*
- 13 (i) Ability of Nickel to form volatile compound which can decompose on further heating.
- (ii) Different components of a mixture are differently adsorbed on an adsorbent
- (or described in any other appropriate manner)** 1+1
- 14 (i) This is due to the ability of oxygen to form multiple bonds to metals.

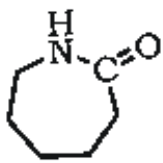
- (ii) This is because the energy required for the promotion of electrons in Xenon is very high. / Energy factor does not favor VB approach.
- (or any other suitable justification)** 1+1
- 15 (i)  $\text{Cr}_2\text{O}_7^{2-} + 14\text{H}^+ + 6\text{I}^- \longrightarrow 2\text{Cr}^{3+} + 3\text{I}_2 + 7\text{H}_2\text{O}$
- (ii)  $2\text{MnO}_4^- + 5\text{NO}_2^- + 6\text{H}^+ \longrightarrow 2\text{Mn}^{2+} + 5\text{NO}_3^- + 3\text{H}_2\text{O}$  1+1
- 16 (i) **Peptide linkage:** A link between two amino acid with loss of water./
- CO – NH –
- Peptide linkage
- (ii) **Biocatalysts:** are the catalysts which increase the rate of metabolism./ biochemical reactions. 1+1
- 17 (i) Despite having the aldehyde group, glucose does not give 2,4-DNP test or Schiff's test.
- (ii) It does not form the hydrogensulphite addition product with  $\text{NaHSO}_3$ .
- (iii) The pentaacetate of glucose does not react with hydroxylamine indicating the absence of free –CHO group.
- (any two)** 1+1
- 18 (i) 
- (ii)  $\text{CH}_2 = \text{CH}-\text{CH}_3$  1+1
- 19 For bcc unit cell
- $$r = \frac{\sqrt{3} a}{4}$$
- $$r = \frac{\sqrt{3} \times 316.5 \text{ pm}}{4} \quad 1$$
- $$r = \frac{1.732 \times 316.5 \text{ pm}}{4} \quad 1$$

$$r = 137 \text{ pm}$$

1

OR

$$d = \frac{z \times M}{a^3 \times N_A}$$

For bcc lattice  $Z=2$ 

$$7.874 \text{ g cm}^{-3} = \frac{2 \times 55.845 \text{ g mol}^{-1}}{(286.65 \times 10^{-10} \text{ cm})^3 \times N_A}$$

$$N_A = \frac{2 \times 55.845 \text{ g mol}^{-1}}{(286.65 \times 10^{-10} \text{ cm})^3 \times 7.874 \text{ g cm}^{-3}}$$

1

$$N_A = 6.02 \times 10^{23} \text{ mol}^{-1}$$

1

20

Since one mole of KCl gives 2 mole particles, the value of

$$\begin{aligned} i &= 2 \\ \Delta T_f &= 2 \text{ K} \\ K_f &= 1.86 \text{ kg mol}^{-1} \end{aligned}$$

1

Applying equation,  $\Delta T_f = iK_f m$

$$m = \frac{\Delta T_f}{iK_f} = \frac{2}{2 \times 1.86} = 0.54 \text{ mol kg}^{-1}.$$

1

Therefore, 0.54 mole of KCl should be added to one kg of water.

1

or

Since one mole of KCl gives 2 mole particles, the value of

$$\begin{aligned} i &= 2 \\ \Delta T_f &= 2 \text{ K} \\ K_f &= 1.86 \text{ kg mol}^{-1} \end{aligned}$$

1

Applying equation,  $\Delta T_f = iK_f m$

$$m = \frac{\Delta T_f}{iK_f} = \frac{2}{2 \times 1.86} = 0.54 \text{ mol kg}^{-1}.$$

1

Therefore, 0.54 mole of KCl should be added to one kg of water.

$$\text{Molar mass of KCl} = 39 + 35.5 = 74.5 \text{ g}$$

$$\text{Amount of KCl} = 0.54 \times 74.5 \text{ g} = 40.05 \text{ g}$$

1

- 21 (a)  $\text{Rate} = k[\text{NO}]^2[\text{Cl}_2]$  1
- (b)  $0.60 \text{ M min}^{-1} = k[0.15]^2 [0.15] \text{ M}^2$   
 $k = 177.7 \text{ M}^{-2} \text{ min}^{-1}$  1
- (c) Initial rate of disappearance of  $\text{Cl}_2$  in exp.4  
 $\text{Rate} = k[\text{NO}]^2[\text{Cl}_2]$   
 $\text{Rate} = 177.7 \text{ M}^{-2} \text{ min}^{-1} \times (0.25)^2 \times (0.25) \text{ M}^3$   
**Rate = 2.8 M min<sup>-1</sup>** 1
- 22 (i) Because small atoms like H, C or N are trapped inside the crystal lattices of transition metals, 1
- (ii) Because of lanthanoid contraction. 1
- (iii) This is due to comparable energies of 5f, 6d and 7s orbitals in actinoids. 1
- 23 (i)  $[\text{Co}(\text{en})_2(\text{NH}_3)\text{Cl}]^{2+}$ : amminechloridobis-(ethane-1,2-diamine) cobalt(III)  $\frac{1}{2} + \frac{1}{2} + \frac{1}{2}$   
**diamagnetic**
- (ii)  $[\text{Ni}(\text{C}_2\text{O}_4)_2(\text{H}_2\text{O})_2]^{-2}$ : diaquadioxalatonicckelate(II),  $\frac{1}{2} + \frac{1}{2} + \frac{1}{2}$   
**paramagnetic**
- 24 Chlorine withdraws electrons through inductive effect and releases through resonance. Although Chlorine shows –I effect but through resonance chlorine tends to stabilize the intermediate carbocation and the effect is more pronounced at ortho- and para-positions. 3  
 (or diagrammatic explanation)
- 25 (i)  $\text{CH}_3\text{CH}_2\text{CH}_2\text{COOH}$   
**Butanoic acid**  $\frac{1}{2} + \frac{1}{2}$
- (ii)  $\text{CH}_3\text{-CH=CH-COOH}$   
**But-2-en-1-oic acid or 2-butenic acid**  $\frac{1}{2} + \frac{1}{2}$
- (iii)  $\text{CH}_3\text{-CH}(\text{CH}_3)\text{-COOH}$   
**2-methylpropanoic acid**  $\frac{1}{2} + \frac{1}{2}$

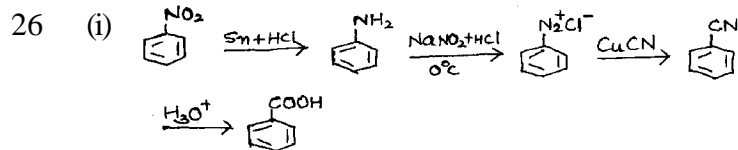

(or any other suitable method)

(ii)

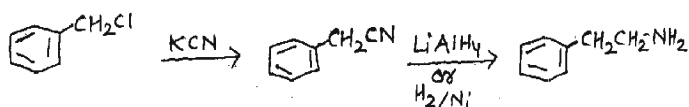

(or any other suitable method)

(iii)

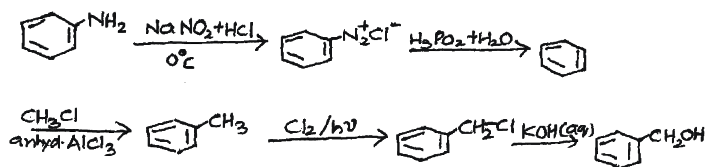

(or any other suitable method)

1x3=3

27. (i) **Tranquilizers** are chemical compounds used for the treatment of stress and mild or even severe mental diseases.

1/2 + 1/2

eg. equanil/meprobamate/veronal (or any one correct example)

(ii) **Food preservatives:** are the compounds which prevent spoilage of food due to microbial growth. eg: sodium benzoate, vinegar

1/2 + 1/2

(or any one correct example)

(iii) **Synthetic Detergents** are cleansing agents which have all the properties of soap but which actually do not contain any soap

1/2 + 1/2

eg: Sodium Lauryl sulphate. (or any one correct example)

28 (a) It is a secondary cell

1/2

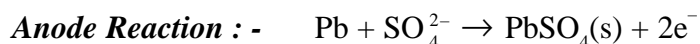

1/2

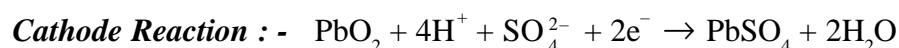

1/2

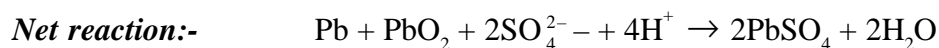

1/2



(b)

$$E^{\circ} \text{ cell} = E^{\circ} \text{ cathode} - E^{\circ} \text{ anode}$$

$$= 0.80 \text{ V} - (-0.76) \text{ V} \quad \frac{1}{2}$$

$$= +1.56 \text{ V} \quad 1$$

$$\Delta rG^{\circ} = -nFE^{\circ} \text{ cell} \quad \frac{1}{2}$$

$$= -2 \times 96500 \text{ C mol}^{-1} \times 1.56 \text{ V}$$

$$= -301080 \text{ J mol}^{-1} \text{ or } -301.08 \text{ kJmol}^{-1} \quad 1$$

**OR**

(a) Molar conductivity : Conductivity of 1 M electrolytic solution placed between two electrodes 1 cm apart and have enough area of cross section to hold the entire volume is known as molar conductivity or conductivity observed for one molar solution of electrolyte 1

Molar conductivity increases with decrease in concentration of solute for both weak and strong electrolytes. (or graphical explanation) 1

(b)  $R = \rho (l/a)$

Cell constant  $l/a = R/\rho = R\kappa$  1

$$= (1500\Omega) \times (0.146 \times 10^{-3} \text{ Scm}^{-1}) \quad 1$$

$$= 0.219 \text{ cm}^{-1} \quad 1$$

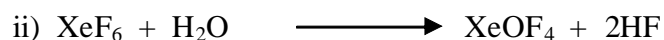

or

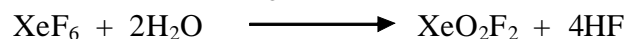

or

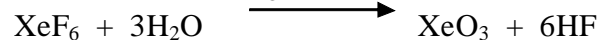

1

(b)

(i) Pyramidal or

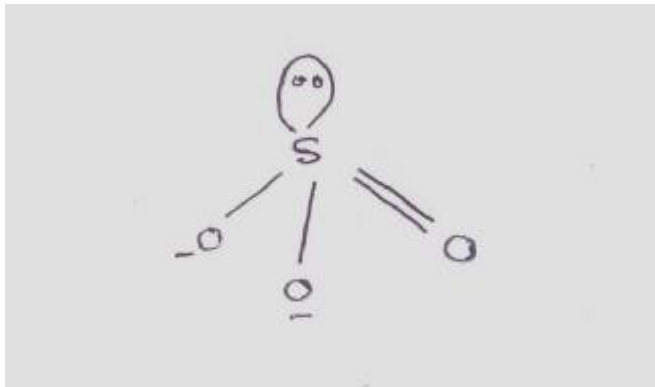

$\frac{1}{2} + \frac{1}{2}$

The angle O-S-O is greater than  $90^\circ$

(ii) Bent T-shaped or

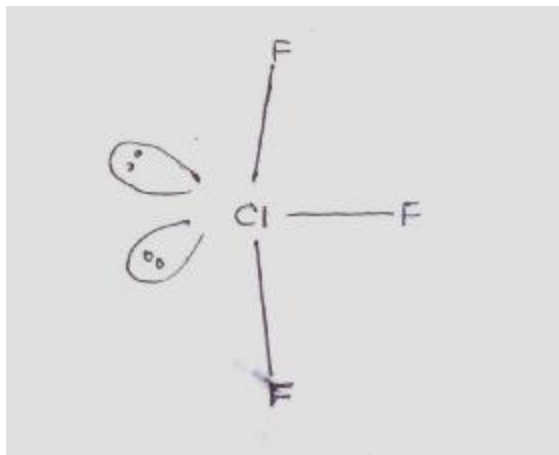

$\frac{1}{2} + \frac{1}{2}$

The angle F-Cl-F is lesser than  $90^\circ$

(iii) Linear Shape or

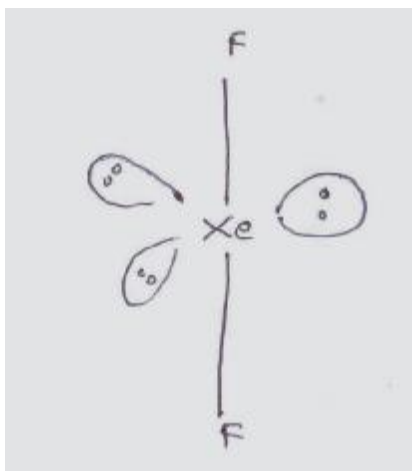

$\frac{1}{2} + \frac{1}{2}$

The angle F-Xe-F is greater than  $90^\circ$

**OR**

(a)

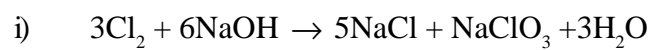

1 + 1

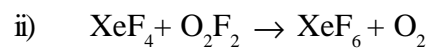

(b) (i)

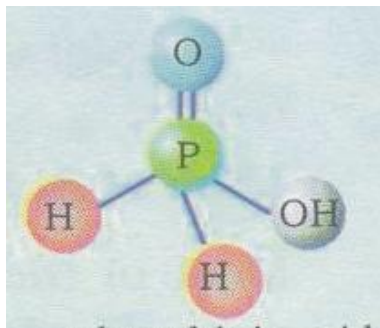

(ii)

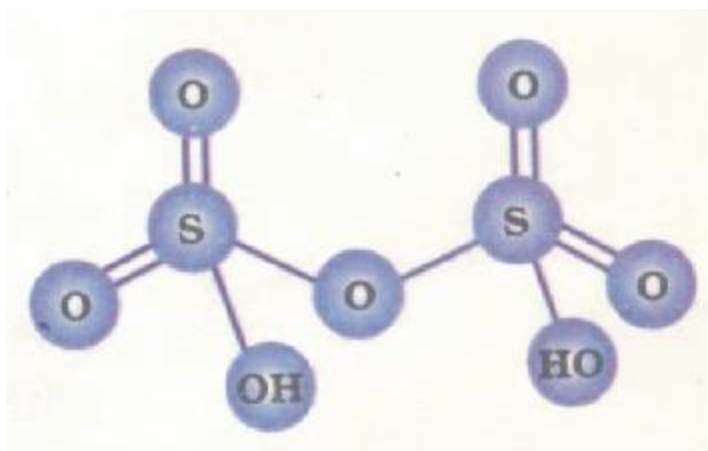

(iii)

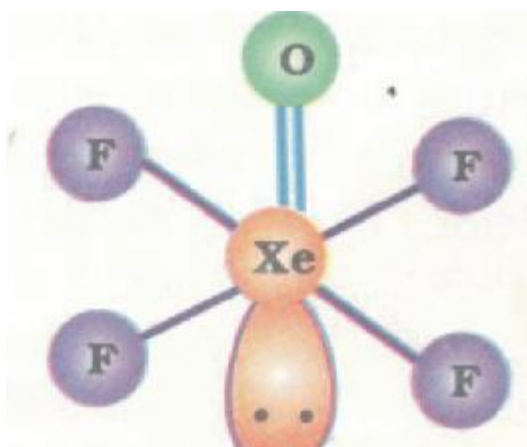

1x3=3

30. (a)

- (i) **Clemmensen reduction:** The carbonyl group of aldehydes and ketones is reduced to  $-\text{CH}_2$  group on treatment with zinc amalgam and concentrated HCl

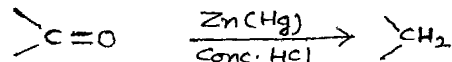

- (ii) **Hell-Volhard-Zelinsky reaction:** Carboxylic acids having an  $\alpha$ -hydrogen are halogenated at the  $\alpha$ -position on treatment with chlorine or bromine in the presence of red phosphorus.

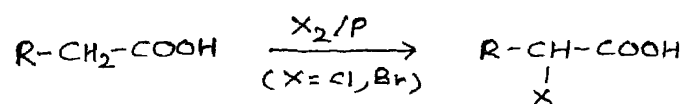

(or by any other suitable method)

1+1

(Note: Award full marks for correct chemical equation; award  $\frac{1}{2}$  mark if only correct statement is written)

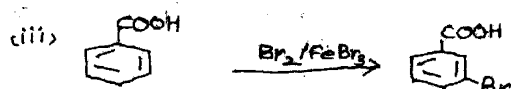
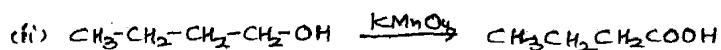
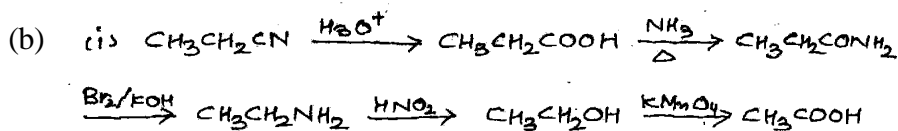

1x3=3

(or any other suitable method can be used for each conversion)

OR

**Cross aldol condensation:** When aldol condensation is carried out between two different aldehydes and/or ketones, it is called Cross aldol condensation

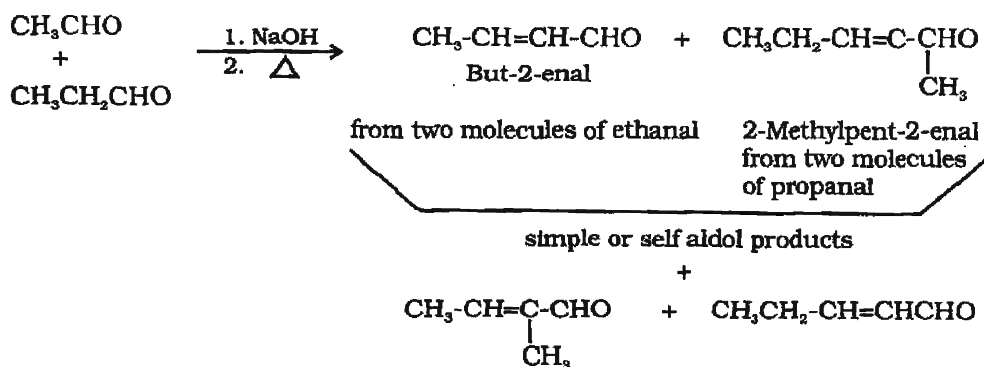

from one molecule of ethanal and one molecule of propanal .

cross aldol products

(only cross aldol products to be considered)

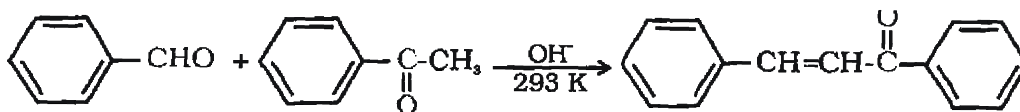

(or any other suitable reaction)

1

- (ii) **Decarboxylation:** Carboxylic acids lose carbon dioxide to form hydrocarbons when their sodium salts are heated with sodalime. The reaction is known as decarboxylation.

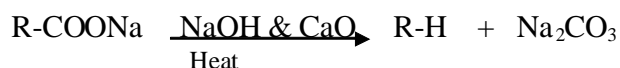

1

(or any other suitable reaction)

(Note: Award full marks for correct chemical equation;  
award ½ mark if only statement is written)

- (b) (i) **Pentan-2-one and Pentan-3-one**

**Iodoform test.** Warm each compound with iodine and sodium hydroxide on a water bath.

**Pentan-3-one** No yellow ppt formed

**Pentan-2-one** Yellow crystals of Iodoform are formed.

(Other relevant test can be accepted)

- (ii) **Benzaldehyde and Acetophenone**

**Iodoform test.** Warm each organic compound with I<sub>2</sub> and NaOH solution.

Acetophenone **Yellow precipitates of iodoform** are formed

Benzaldehyde does not respond to this test.

(Other relevant test can be accepted)

- (iii) **Phenol and Benzoic acid :** Add neutral FeCl<sub>3</sub> to both of them. Phenol gives violet colour.

(Other relevant test can be accepted) 1x3= 3

QUESTION PAPER CODE 56/1

EXPECTED ANSWERS/VALUE POINTS

1. Their conductivity is increased by adding an appropriate amount of suitable impurity / by doping. 1
2. The process of converting precipitates of a substance into colloidal form by adding small amount of electrolyte is called peptization. 1
3. By hydrometallurgy 1
4.  $\text{BiH}_3$ , because the stability of hydrides decreases on moving from  $\text{SbH}_3$  to  $\text{BiH}_3$ .  $\frac{1}{2} + \frac{1}{2}$
5.  $\text{CH}_2=\text{CH}-\text{CH}_2-\text{C}\equiv\text{CH} + \text{Br}_2 \longrightarrow \begin{array}{c} \text{CH}_2-\text{CH}-\text{CH}_2-\text{C}\equiv\text{CH} \\ | \quad | \\ \text{Br} \quad \text{Br} \end{array}$  1  
 or colour of Bromine get discharged or any other correct suitable answer.
6. Pent-2-enal 1
7.  $\begin{array}{c} \text{COOH} \\ | \\ (\text{CHOH})_4 \\ | \\ \text{COOH} \end{array}$  1  
 Saccharic acid
8. Antiseptics are applied to the living tissues whereas disinfectants are applied to inanimate objects / non-living objects. 1
9.  $k = 1/R (l/A)$  1  
 Where k is conductivity, R is resistance and  $l/A$  is cell constant  
 $\Lambda_m = k/C$   
 Where  $\Lambda_m$  is molar conductivity  
 C is concentration 1

OR

$$\Lambda_m = 138.9 \text{ S cm}^2 \text{ mol}^{-1} \quad M = 1.5 \text{ M} \quad K = ?$$

$$\Lambda_m = \frac{1000 K}{M} \quad K = \frac{\Lambda_m \times M}{1000} \quad 1$$

$$K = \frac{138.9 \times 1.5}{1000} = 0.20835 \text{ Scm}^{-1} \quad 1$$

10. For the reaction  $A \longrightarrow \text{Product}$

(i) Rate of reaction becomes 4 times

(i) Rate of reaction decreases by 4 times 1+1

11. (i) **Nickel:-** Mond Process

**Principle** the metal is converted into its volatile compound which is then decomposed to give pure metal at higher temperature. ½ + ½

(ii) **Germanium:-** Zone refining

**Principle** that the impurities are more soluble in the melt than in the solid state of the metal. ½ + ½

12. (i) Because bond energy of  $F_2$  is lower than that of  $Cl_2$  and therefore F forms stronger bond with N with the release of energy. 1

(ii)  $SF_4$  has trigonal bipyramidal structure with one l.p. Due to l.p-b.p repulsion two axial S-F bonds are longer than two S-F equatorial bonds. 1

13. (i)  $Cr_2O_7^{2-} + 14H^+ + 6I^- \longrightarrow 2Cr^{3+} + 3I_2 + 7H_2O$  1

(ii)  $2MnO_4^- + 6H^+ + 5NO_2^- \longrightarrow 2Mn^{2+} + 5NO_3^- + 3H_2O$  1

14. **Mechanism:-** The mechanism of the reaction involves the following three steps:

Step 1: Protonation of alkene to form carbocation by electrophilic attack of  $H_3O^+$ .

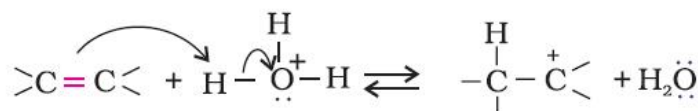

Step 2: Nucleophilic attack of water on carbocation

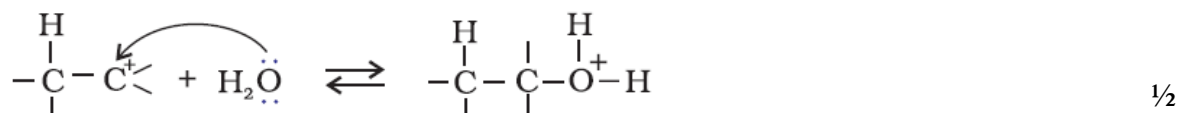

Step 3: Deprotonation to form an alcohol

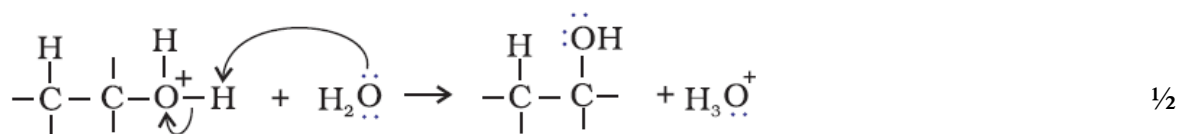

15. (i) Alcohols are more soluble in water because of the formation of hydrogen bond whereas hydrocarbon cannot form hydrogen bond with water.
- (ii) This is because  $-\text{NO}_2$  group is electron withdrawing and therefore stabilize phenoxide ion whereas  $-\text{OCH}_3$  group is electron donating which destabilize phenoxide ion.

(or any other correct suitable answer) 1+1

16. (i) **Carbylamine reaction:-**

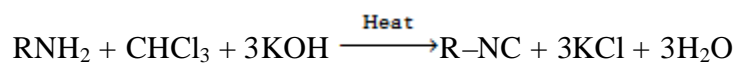

- (ii) **Hoffmann bromamide reaction:-**

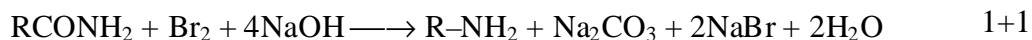

17. (i)  $\text{C}_6\text{H}_5\text{N}_2^+\text{Cl}^- + \text{H}_3\text{PO}_2 + \text{H}_2\text{O} \longrightarrow \text{C}_6\text{H}_6 + \text{N}_2 + \text{H}_3\text{PO}_3 + \text{HCl}$

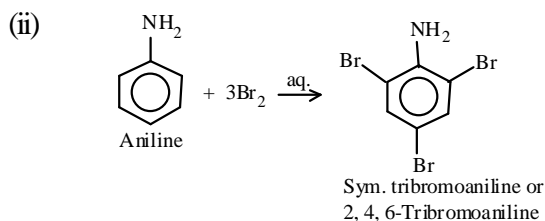

1+1

18. Food preservatives are chemicals that prevent food from spoilage due to microbial growth.

Examples of food preservatives: - Table salt, sugar, vegetable oil, sodium benzoate ( $\text{C}_6\text{H}_5\text{COONa}$ ), and salts of propanoic acid. (any two) 1+ 1/2 + 1/2

19.  $d = \frac{z \times M}{a^3 \times N_A}$  1/2

For fcc lattice for copper

$$a = 2\sqrt{2} r \quad \frac{1}{2}$$



$$a^3 = (2\sqrt{2}r)^3 = 8 \times 2\sqrt{2} (1.278 \times 10^{-8} \text{cm})^3$$

$$= 4.723 \times 10^{-23} \text{cm}^3$$

$$d = \frac{4 \times 63.55 \text{ g mol}^{-1}}{4.723 \times 10^{-23} \text{ cm}^3 \times 6.02 \times 10^{23} \text{ mol}^{-1}} \quad 1$$

$$= \mathbf{8.95 \text{ g cm}^{-3}} \quad 1$$

Or

$$N_A = \frac{z \times M}{d \times a^3} \quad 1$$

$$= \frac{2 \times 56 \text{ g mol}^{-1}}{7.87 \text{ g cm}^{-3} \times (2.8665)^3 \times 10^{-24} \text{ cm}^3} \quad 1$$

$$N_A = 6.043 \times 10^{23} \text{ mol}^{-1} \quad 1$$

20  $A = \pi r^2 = 3.14 \times 0.52 \text{ cm}^2 = 0.785 \text{ cm}^2 = 0.785 \times 10^{-4} \text{ m}^2$        $l = 50 \text{ cm} = 0.5 \text{ m}$

$$R = \frac{\rho l}{A} \quad \text{or} \quad \rho = \frac{RA}{l}$$

$$\rho = \frac{5.55 \times 10^8 \Omega \times 0.785 \text{ cm}^2}{50 \text{ cm}} = 87.135 \Omega \text{cm} \quad 1$$

$$\text{Conductivity} = K = \frac{1}{\rho}$$

$$= \frac{1}{87.135} \text{ S cm}^{-1} = 0.01148 \text{ S cm}^{-1} \quad 1$$

$$\text{Molar conductivity, } \Lambda_m = \frac{1000 K}{M}$$

$$= \frac{0.01148 \text{ S cm}^{-1} \times 1000 \text{ cm}^3 \text{ L}^{-1}}{0.05} = 229.6 \text{ S cm}^2 \text{ mol}^{-1} \quad 1$$

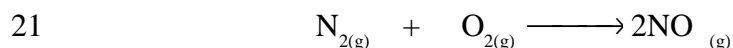

Initial Conc.	0.80M	0.20M	0	
Final Conc.	(0.80 - x)	(0.20 - x)	2x	1

$$K_c = \frac{[\text{NO}]^2}{[\text{N}_2] \times [\text{O}_2]}$$

$$1 \times 10^{-5} = \frac{[2x]^2}{[0.80 - x] \times [0.20 - x]} \quad \text{Thus } x = 0.66 \times 10^{-3} \text{ (approx)}$$

1

At equilibrium  $[\text{NO}] = 2x = 1.32 \times 10^{-3}$ .

(Note: any attempt whatsoever made may be awarded full marks.)

1

- 22 (i) **Aerosol:** A colloidal solution having a gas as the dispersion medium and a solid / liquid as the dispersed phase is called an aerosol. For example: fog, smoke, dust (**any one**) 1/2+ 1/2
- (ii) **Emulsion:** The colloidal solution in which both the dispersed phase and dispersion medium are liquids is called an emulsion. For example: milk, cold cream (**any one**) 1/2+ 1/2
- (iii) **Micelles:** There are some substances which at low concentrations behave as normal strong electrolytes, but at higher concentrations exhibit colloidal behaviour due to the formation of aggregates. The aggregated particles thus formed are called **micelles**.  
eg. Soap, detergents (**any one**) 1/2+ 1/2
- 23 (i) Lanthanoid Metals show +2 and +4 oxidation states to attain stable  $f^0$  and  $f^7$  configurations.
- (ii) Because of high enthalpy of atomization and ionization which is not compensated by the enthalpy of hydration of  $\text{Cu}^{2+}$ .
- ii) Due to lanthanoid contraction. 1x3=3
- 24 (i) Dichloridobis (ethane-1,2-diamine) cobalt(III) ion

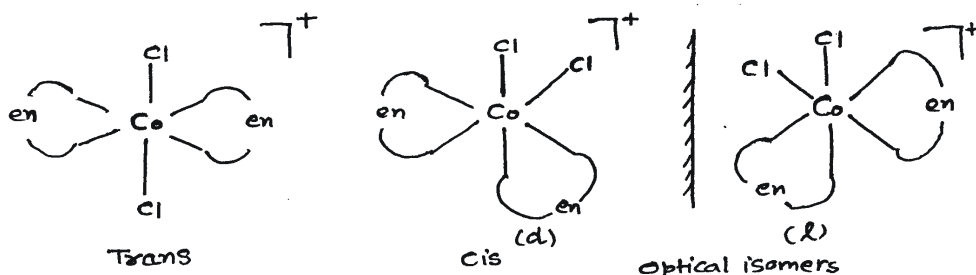

1/2 + 1/2

(ii) Trioxalatochromate(III)

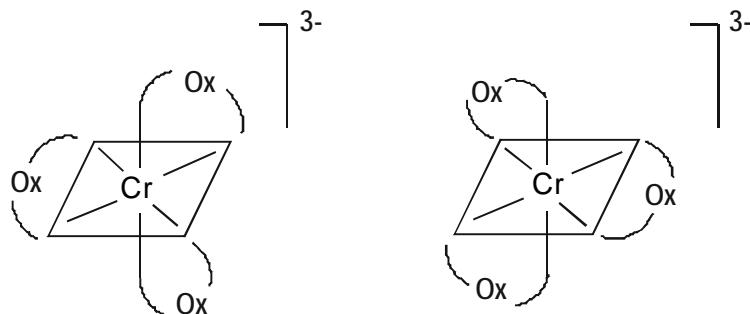

$\frac{1}{2} + \frac{1}{2}$

(iii) Triamminetrichloridocobalt(III)

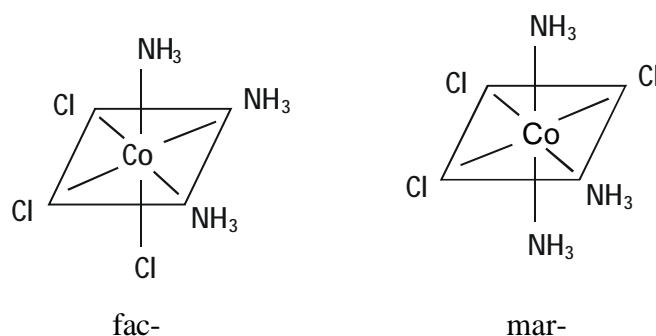

$\frac{1}{2} + \frac{1}{2}$

25. (i) The objects which are non superimposable on their mirror image are said to be **chiral** and this property is known as **chirality**

eg. Butan-2-ol

$\frac{1}{2} + \frac{1}{2}$

(ii)  $\text{CH}_3\text{CHClCH}_2\text{CH}_3$

because it will form secondary carbocation which is more stable ( $\text{SN}_1$  mechanism) or  $\text{CH}_3\text{CH}_2\text{CH}_2\text{CH}_2\text{Cl}$  is easily hydrolysed as it is primary alkyl halide ( $\text{SN}_2$  mechanism)

$\frac{1}{2} + \frac{1}{2}$

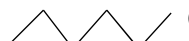
(iii)  I reacts faster than  Cl

$\frac{1}{2} + \frac{1}{2}$

Because Iodine has larger size and therefore good leaving group.

26.  $\alpha$ -glucose &  $\beta$  glucose differ only in the orientation of the hydroxyl group at  $\text{C}_1$  position. In  $\alpha$ -glucose the OH group is on right hand side at  $\text{C}_1$  position whereas in  $\beta$ -glucose the OH group is on left hand side at  $\text{C}_1$  position.

The six membered hetero cyclic structure of glucose is called **pyranose structure** (or structures)

1

27 Thermoplastic polymers: - These are the linear or slightly branched long chain molecules capable of repeatedly softening on heating and hardening on cooling. 1

Some common examples are polythene, polystyrene, polyvinylchloride (**any one**) ½

**Thermosetting polymers:-** These polymers are cross linked or heavily branched molecules, which on heating undergo extensive cross linking in moulds and again become infusible. These cannot be reused. Some common examples are bakelite, urea-formaldehyde resins (**any one**) 1  
½

28 (a) (i) The Ratio of number of moles of one component to the total number of moles of solution. / or mathematical expression. 1+1

(ii) The Solution which follows Raoult's law over the entire range of concentrations.

(b)  $W_B = 15 \text{ g}$        $W_A = 450 \text{ g}$

$\Delta T_f = 0.34^\circ\text{C}$      $K_f = 1.86 \text{ Kkg/mol}$        $M_B = ?$  1

$$M_B = \frac{1000 \times K_f \times W_B}{\Delta T_f \times W_A}$$

$$= \frac{1000 \times 1.86 \text{ K kg mol}^{-1} \times 15 \text{ g}}{0.34 \text{ K} \times 450 \text{ g}} \quad 1$$

$$= 182.35 \text{ g/mol} \quad 1$$

**Or**

(a) (i) The Partial pressure of the gas above the liquid is directly proportional to the mole fraction of the gas dissolved in the liquid. 1

(ii) **Boiling Point Elevation Constant.** It is equal to elevation in boiling point of 1 molal solution, i.e., 1 mole of solute is dissolved in 1 kg of solvent. (or mathematical expression) 1

(b)  $W_B = ?$        $W_A = 500 \text{ g}$        $\Delta T_b = 100.42^\circ\text{C} - 100^\circ\text{C} = 0.42^\circ\text{C}$  or  $0.42 \text{ K}$

$K_b = 0.512 \text{ Kkg/mol}$        $M_B = 92 \text{ g/mol}$

$$\Delta T_b = K_b \frac{W_B \times 1000}{M_B \times W_A(\text{in grams})}$$

$$W_B = \frac{\Delta T_b \times M_B \times W_A(\text{in grams})}{1000 \times K_b} \quad 1$$

$$= \frac{042\text{K} \times 92\text{g mol}^{-1} \times 500\text{kg}}{1000 \times 0.512\text{K kg mol}^{-1}} \quad 1$$

$$W_B = 37.73 \text{ g} \quad 1$$

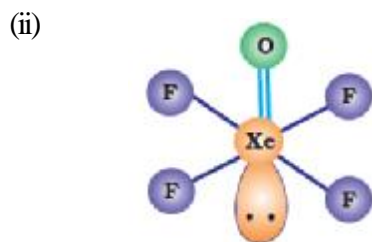
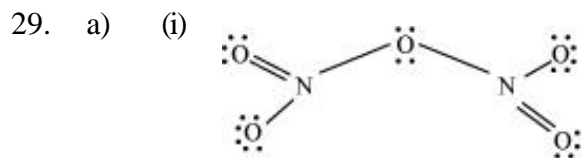

1+1

(b)

(i) Because S-S single bond is stronger than O-O single bond.

(ii) Because I-Cl bond has lower bond dissociation enthalpy than I-I bond.

(iii) Because of lower bond dissociation enthalpy and high hydration enthalpy of Fluorine.

1×3=3

**Or**

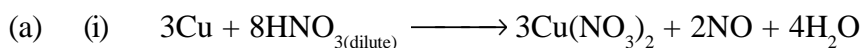

(b) (i) Because P-P single bond is stronger than N-N single bond.

(ii) Due to smaller size of oxygen it forms  $p\pi-p\pi$  bonds and form  $\text{O}_2$  ( $\text{O}=\text{O}$ ) which is absent in sulphur due to which it acquires a stable ring structure.

(iii) Because halogens absorb radiations in the visible region. This results in the excitation of valence electrons to a higher energy region.

1×3=3

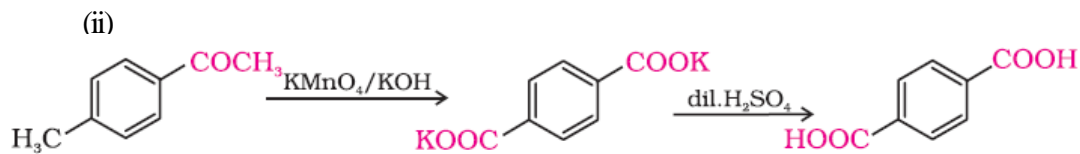
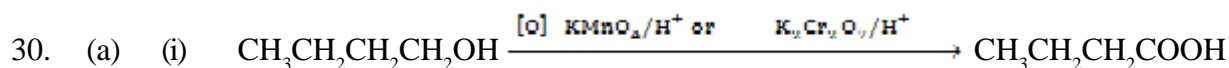

1+1

4-Methylacetophenone

Dipotassium benzene-1,4-dicarboxylate

Benzene-1,4-dicarboxylic acid  
(Terephthalic acid)

- (b) It is given that the compound (with molecular formula  $\text{C}_9\text{H}_{10}\text{O}$ ) forms 2,4-DNP derivative and reduces Tollen's reagent. Therefore, the given compound must be an aldehyde. Again, the compound undergoes cannizzaro reaction and on oxidation gives 1,2-benzenedicarboxylic acid. Therefore, the -CHO group is directly attached to a benzene ring and this benzaldehyde is ortho-substituted. Hence, the compound is 2-ethylbenzaldehyde.

2

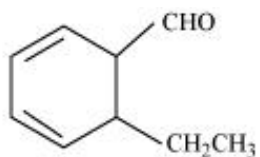

1

2 - Ethylbenzaldehyde

**(or the given reactions can be explained by the equations)**

**Or**

- (a) (i) Add  $\text{I}_2$  & NaOH (Iodoform test) in both the compounds, propanone give yellow ppt of  $\text{CHI}_3$  Iodoform. ( Or any other suitable test) 1
- (ii) Add  $\text{I}_2$  & NaOH (Iodoform test) in both the compounds, acetophenone give yellow ppt of  $\text{CHI}_3$  Iodoform. Or benzaldehyde will give silver mirror test with tollens reagent. 1
- (b) (i) Methyl tert - butyl ketone < acetone < acetaldehyde.
- (ii) 4 - Methoxy benzoic acid < Benzoic acid < 3,4 - Dinitobenzoic acid.  $1 \times 3 = 3$
- (iii)  $(\text{CH}_3)_2\text{CHCOOH} < \text{CH}_3\text{CH}(\text{Br})\text{CH}_2\text{COOH} < \text{CH}_3\text{CH}_2\text{CH}(\text{Br})\text{COOH}$ .

# BIOLOGY (Theory)

Time allowed : 3 hours

Maximum Marks : 70

## General Instructions:

- (i) All questions are compulsory.
- (ii) The question paper consists of four sections A, B, C and D. Section A contains 8 questions of one mark each, Section B is of 10 questions of two marks each, Section C is of 9 questions of three marks each and Section D is of 3 questions of five marks each.
- (iii) There is no overall choice. However, an internal choice has been provided in one question of 2 marks, one question of 3 marks and all the three questions of 5 marks weightage. A student has to attempt only one of the alternatives in such questions.
- (iv) Wherever necessary, the diagrams drawn should be neat and properly labelled.

## QUESTION PAPER CODE 57/1/1

### SECTION A

1. Mention the unique flowering phenomenon exhibited by *Strobilanthus kunthiana* (neelakuranaji). 1
2. How does smoking tobacco in human lead to oxygen deficiency in their body? 1
3. A garden pea plant (A) produced inflated yellow pod, and another plant (B) of the same species produced constricted green pods. Identify the dominant traits. 1
4. Why is *Eichhornia crassipes* nicknamed as "Terror of Bengal" ? 1
5. Write the location and function of the sertoli cells in humans. 1
6. Name the following: 1
  - (a) The semi-dwarf variety of wheat which is high-yielding and disease-resistant.
  - (b) Any one inter-specific hybrid mammal.

7. Write the similarity between the wing of a butterfly and the wing of a bat. What do you infer from the above with reference to evolution? 1
8. Write what do phytophagous insects feed on. 1

### SECTION - B

9. Draw a neat labelled sketch of a replicating fork of DNA. 2
10. Where is sporopollenin present in plants? State its significance with reference to its chemical nature. 2
11. (a) Highlight the role of thymus as a lymphoid organ. 2  
(b) Name the cells that are released from the above mentioned gland. Mention how they help in immunity.
12. Explain the work carried out by Cohen and Boyer that contributed immensely in biotechnology. 2
13. Why do clown fish and sea anemone pair up ? What is this relationship called? 2
14. (a) State the difference between meiocyte and gamete with respect to chromosome number. 2  
(b) Why is a whiptail lizard referred to as parthenogenetic?
15. Name the plant source of the drug popularly called "smack". How does it affect the body of the abuser? 2

### OR

Why is *Rhizobium* categorized as a 'symbiotic bacterium' ? How does it act as a biofertiliser ?

16. (a) State the role of DNA ligase in biotechnology. 2  
(b) What happens when *Meloidegryne incognitia* consumes cells with RNAi gene?
17. Some organisms suspend their metabolic activities to survive in unfavourable conditions. Explain with the help of any four examples. 2



18. (a) Name the Protozoan parasite that causes amoebic dysentery in humans.  
 (b) Mention two diagnostic symptoms of the disease.  
 (c) How is this disease transmitted to others?

**SECTION - C**

19. It is established that RNA is the first genetic material. Explain giving three reasons. 3

**OR**

- (a) Name the enzyme responsible for the transcription of tRNA and the amino acid the initiator tRNA gets linked with.  
 (b) Explain the role of initiator tRNA in initiation of protein synthesis.
20. State the theory of Biogenesis. How does Miller's experiment support this theory? 3
21. Name the two different categories of microbes naturally occurring in sewage water. Explain their role in cleaning sewage water into usable water. 3
22. Write the function of each one of the following:  
 (a) (Oviducal) Fimbriae  
 (b) Coleoptile  
 (c) Oxytocin
23. Name the genes responsible for making Bt cotton plants resistant to bollworm attack. How do such plants attain resistance against bollworm attacks? Explain. 3
24. Study a part of the life cycle of malarial parasite given below. Answer the questions that follows: 3

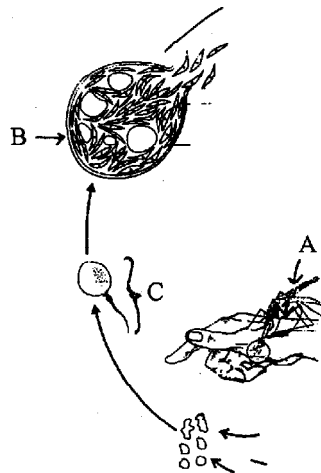

- (a) Mention the roles of 'A' in the life cycle of the malarial parasite.
- (b) Name the event 'C' and the organ where this event occurs.
- (c) Identify the organ 'B' and name the cells being released from it.

25. Given below is the representation of amino acid composition of the relevant translated portion of  $\beta$ -chain of haemoglobin, related to the shape of human red blood cells.

3

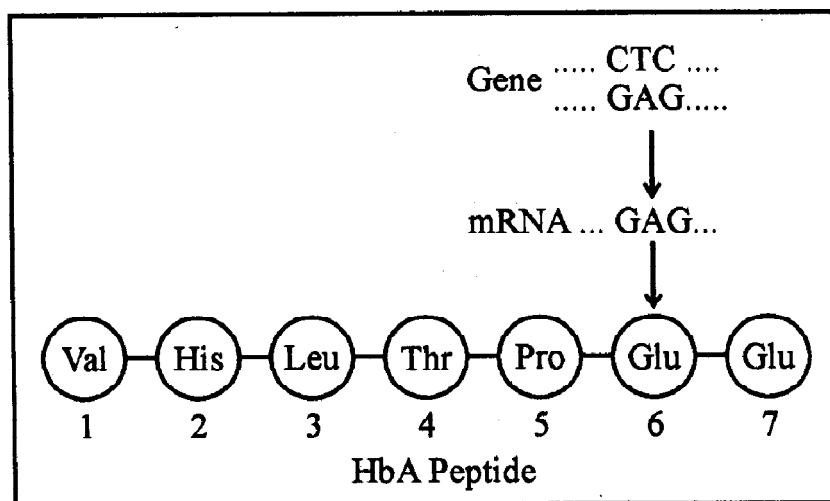

- (a) Is this representation indicating a normal human or a sufferer from certain related genetic disease? Give reason in support of your answer.
- (b) What difference would be noticed in the phenotype of the normal and the sufferer related to this gene?
- (c) Who are likely to suffer more from the defect related to the gene represented –the males, the females or both males and females equally? And why?

26. By the end of 2002 the public transport of Delhi switched over to a new fuel. Name the fuel. Why is this fuel considered better? Explain.

3

27. Draw a schematic sketch of pBR 322 plasmid and label the following in it :

- (a) Any two restriction sites.
- (b) Ori and rop genes.
- (c) An antibiotic resistant gene.

**SECTION - D**

28. Explain the carbon cycle with the help of a simplified model. 5

**OR**

Explain how does:

- (a) a primary succession start on a bare rock and reach a climax community?
  - (b) the algal bloom eventually choke the waterbody in an industrial area?
29. The following is the illustration of the sequence of ovarian events (a – i) in a human female. 5

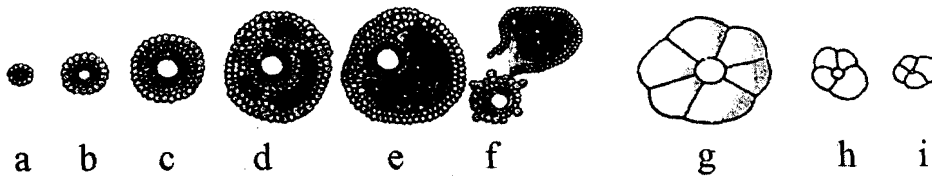

- (i) Identify the figure that illustrates ovulation and mention the stage of oogenesis it represents.
- (ii) Name the ovarian hormone and the pituitary hormone that have caused the above mentioned event.
- (iii) Explain the changes that occur in the uterus simultaneously in anticipation.
- (iv) Write the difference between 'c' and 'h'.
- (v) Draw a labelled sketch of the structure of a human ovum prior to fertilization.

**OR**

How does the megaspore mother cell develop into 7-celled, 8 nucleate embryo sac in an angiosperm? Draw a labelled diagram of a mature embryo sac.

30. What is the inheritance pattern observed in the size of starch grains and seed shape of *Pisum sativum*? Work out the monohybrid cross showing the above traits. How does this pattern of inheritance deviate from that of Mendelian law of dominance? 5

**OR**

State the aim and describe Messelson and Stahl's experiment.

**QUESTION PAPER CODE 57/1**

**SECTION A**

1. Why is banana considered a good example of parthenocarpy? 1
2. State two different roles of spleen in the human body. 1
3. A garden pea plant produced axial white flowers. Another of the same species produced terminal violet flowers. Identify the dominant traits. 1
4. Why is it desirable to use unleaded petrol in vehicles fitted with catalytic converters? 1
5. Where is acrosome present in humans? Write its function. 1
6. Write the name of the following: 1
  - (a) The most common species of bees suitable for apiculture
  - (b) An improved breed of chicken
7. Comment on the similarity between the wing of a cockroach and the wing of a bird. What do you infer from the above, with reference to evolution? 1
8. Mention the role of cyanobacteria as a biofertiliser. 1

**SECTION B**

9. (a) Draw a neat labelled diagram of a nucleosome. 2  
(b) Mention what enables histones to acquire a positive charge.
10. State one advantage and one disadvantage of cleistogamy. 2
11. (a) Where do the signals for parturition originate from in humans? 2  
(b) Why is it important to feed the newborn babies on colostrum?
12. (a) A recombinant vector with a gene of interest inserted within the gene of  $\alpha$ -galactosidase enzyme, is introduced into a bacterium. Explain the method that would help in selection of recombinant colonies from non-recombinant ones.  
(b) Why is this method of selection referred to as "insertional inactivation"? 2

13. Explain brood parasitism with the help of an example. 2
14. Give reasons for the following: 2
- (a) The human testes are located outside the abdominal cavity..
- (b) Some organisms like honey-bees are called parthenogenetic animals.
15. Name the plant source of *ganja*. How does it affect the body of the abuser? 2

**OR**

Name the two special types of lymphocytes in humans. How do they differ in their roles in immune response?

16. (a) Mention the cause and the body system affected by ADA deficiency in humans. 2
- (b) Name the vector used for transferring ADA-DNA into the recipient cells in humans. Name the recipient cells.
17. How did Ahmed Khan, plastic sacks manufacturer from Bangalore, solve the ever-increasing problem of accumulating plastic waste? 2
18. Name the bacterium that causes typhoid. Mention two diagnostic symptoms. How is this disease transmitted to others? 2

**SECTION C**

19. (a) Explain the phenomena of multiple allelism and co-dominance taking ABO blood group as an example.
- (b) What is the phenotype of the following:
- (i)  $I^A i$
- (ii)  $ii$  3
20. How does industrial melanism support Darwin's theory of Natural Selection? Explain. 3
21. (a) What is the programme called that is involved in improving success rate of production of desired hybrid and herd size of cattle?
- (b) Explain the method used for carrying this programme for cows. 3

22. Explain the function of each of the following: 3
- (a) Coleorhiza
  - (b) Umbilical cord
  - (c) Germ pores
23. How is the amplification of a gene sample of interest carried out using Polymerase Chain Reaction (PCR) ? 3
24. Trace the life-cycle of malarial parasite in the human body when bitten by an infected female *Anopheles*. 3
25. List the salient features of double helix structure of DNA. 3

**OR**

How are the structural genes activated in the lac operon in *E. coli*?

26. Alien species are highly invasive and are a threat to indigenous species. Substantiate this statement with any three examples. 3
27. (a) Tobacco plants are damaged severely when infested with *Meloidogyne incognita*. Name and explain the strategy that is adopted to stop this infestation.
- (b) Name the vector used for introducing the nematode specific gene in tobacco plant. 3

### SECTION D

28. (a) Taking one example each of habitat loss and fragmentation, explain how are the two responsible for biodiversity loss.
- (b) Explain two different ways of biodiversity conservation. 5

**OR**

- (a) What depletes ozone in the stratosphere? How does this affect human life?
- (b) Explain biomagnification of DDT in an aquatic food chain. How does it affect the bird population?

29. The following is the illustration of the sequence of ovarian events "a" to "i" in a human female:

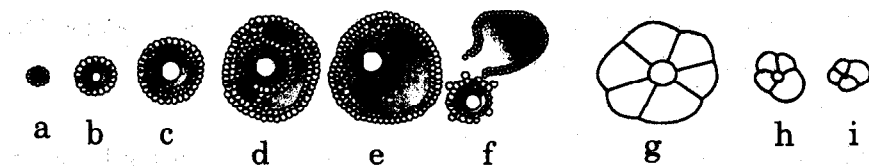

- (a) Identify the figure that illustrates corpus luteum and name the pituitary hormone that influences its formation.
- (b) Specify the endocrine function of corpus luteum. How does it influence the uterus? Why is it essential?
- (c) What is the difference between "d" and "e" ?
- (d) Draw a neat labelled sketch of Graafian follicle. 5
- OR**
- (a) Why is fertilisation in an angiosperm referred to as double fertilisation ? Mention the ploidy of the cells involved.
- (b) Draw a neat labelled sketch of L.S. of an endospermous monocot seed.
30. Describe Frederick Griffith's experiment on *Streptococcus pneumoniae*. Discuss the conclusion he arrived at. 5

**OR**

- (a) Explain a monohybrid cross taking seed coat colour as a trait in *Pisum sativum*. Work out the cross up to F<sub>2</sub> generation.
- (b) State the laws of inheritance that can be derived from such a cross.
- (c) How is the phenotypic ratio of F<sub>2</sub> generation different in a dihybrid cross?

## Marking Scheme — Biology (Theory)

### General Instructions :

#### *The Marking Scheme and mechanics of marking*

1. In the marking scheme the marking points are separated by commas, one oblique line (/) indicates acceptable alternative, two obliques (//) indicate complete acceptable alternative set of marking points.
2. Any words/phrases given within brackets do not carry marks.
3. Allow spelling mistakes unless the misspelt word has another biological meaning. Ignore plurals unless otherwise stated in the marking scheme.
4. In any question exclusively on diagram no marks on any description. But in questions on descriptions, same value points may be marked on the diagrams as a substitute.
5. All awarded marks are to be written in the left hand margin at the end of the question or its part.
6. Place a tick (✓) in red directly on the key/operative term or idea provided it is in correct context. Place “Half-tick” ½ wherever there is ½ mark in the marking scheme. (Do not place tick indiscriminately just to show that you have read the answer).
7. If no marks are awarded to any part or question put a cross (×) at incorrect value portion and mark it zero (in words only).
8. Add up ticks or the half ticks for a part of the question, do the calculation if any, and write the part total or the question total in the left hand margin.
9. Add part totals of the question and write the question total at the end. Count all the ticks for the entire question as a recheck and draw a circle around the question total to confirm correct addition.
10. If parts have been attempted at different places do the totalling at the end of the part attempted last.
11. If any extra part is attempted or any question is reattempted, score out the last one and write “extra”.
12. In questions where only a certain number of items are asked evaluate only that many numbers in sequence as is asked ignoring all the extra ones even if otherwise correct.
13. Transcribe the marks on the cover page. Add up question totals. Recheck the script total by adding up circled marks in the script.
14. Points/answer given in brackets in marking scheme are not so important and may be ignored for marking.
15. **In compliance to the judgement of the Hon’ble Supreme Court of India, Board has decided to provide photocopy of the answer book(s) to the candidates who will apply for it alongwith the requisite fee from 2012 examination. Therefore, it is all the more**



important that the evaluation is done strictly as per the value points given in the marking scheme so that the Board could be in a position to defend the evaluation at any forum.

16. The Examiner shall also have to certify in the answer book that they have evaluated the answer book strictly in accordance with the value points given in the marking scheme and correct set of question paper.

## Question Paper Code 57/1/1

### SECTION – A

*Q. Nos. 1 - 8 are of one marks each*

1. **Mention the unique flowering phenomenon exhibited by *Strobilanthus kunthiana* (neelakuranaji).**

Ans. It flowers once in 12 years.

[1 mark]

2. **How does smoking tobacco in human lead to oxygen deficiency in their body ?**

Ans. Smoking increases CO content in the blood / greater affinity of CO to haemoglobin / CO forms a stable bond with haemoglobin / presence of CO does not allow oxygen to bind with haemoglobin // Smoking damages alveolar walls due to which respiratory surface is decreased (Emphysema) (Leads to lesser diffusion of oxygen in blood).

[1 mark]

3. **A garden pea plant (A) Produced inflated yellow pod, and another plant (B) of the same species produced constricted green pods. Identify the dominant traits.**

Ans. Inflated , green pods =  $\frac{1}{2} + \frac{1}{2}$

[1 mark]

4. **Why is *Eichhornia crassipes* nicknamed as “Terror of Bengal” ?**

Ans. It (is an invasive weed) and grows very fast , causes oxygen depletion leading to death of aquatic life or fishes // Eutrophication =  $\frac{1}{2} + \frac{1}{2}$

[1 mark]

5. **Write the location and function of the Sertoli cells in humans.**

Ans. In the seminiferous tubules / testes , nourishes sperms / germ cells =  $\frac{1}{2} + \frac{1}{2}$

[1 mark]

6. Name the following:

- (a) The semi-dwarf variety of wheat which is high-yielding and disease-resistant.
- (b) Any one inter-specific hybrid mammal.

Ans. (a) Kalyan Sona / Sonalika =  $\frac{1}{2}$

(b) Mule / Hinny / Liger / Tigon =  $\frac{1}{2}$

[1 mark]

7. Write the similarity between the wing of a butterfly and the wing of a bat. What do you infer from the above with reference to evolution ?

Ans. Similar in function (fly) / different in structure and origin / analogous organs , convergent evolution =  $\frac{1}{2} + \frac{1}{2}$

[1 mark]

8. Write what do phytophagous insects feed on.

Ans. Feed on plant parts / plant sap.

[1 mark]

### SECTION - B

*Q. Nos. 9 - 18 are of two marks each*

9. Draw a neat labelled sketch of a replicating fork of DNA.

Ans.

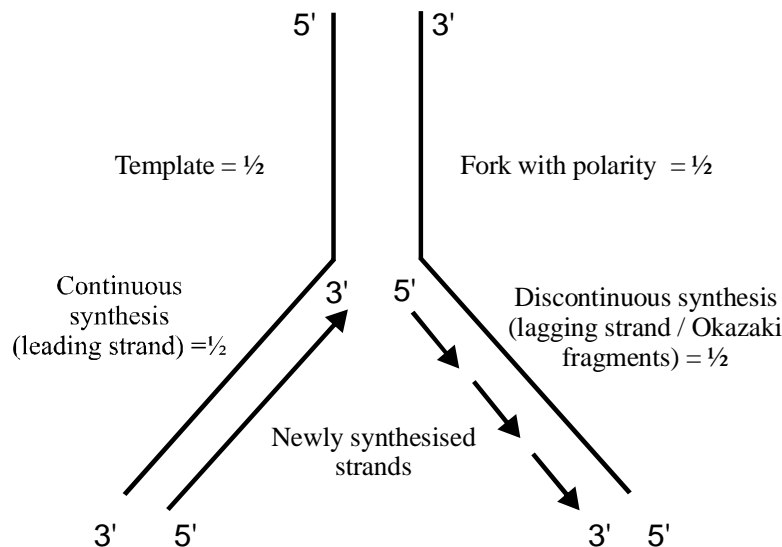

Polarity of the two strands of the fork to be shown and polarity as well as arrow mark of the lagging and leading strands to be shown with correct labelings =  $\frac{1}{2} \times 4$

[2 marks]

**10. Where is sporopollenin present in plants ? State its significance with reference to its chemical nature.**

Ans. Present in exine , of pollen / pollen grain =  $\frac{1}{2} + \frac{1}{2}$

Sporopollenin is the most resistant organic material hence protects the pollen / gamete / gametophyte, provides protection to pollen from unfavourable conditions or chemicals (acids, enzymes, high temperature etc.) =  $\frac{1}{2} + \frac{1}{2}$

[2 marks]

**11. (a) Highlight the role of thymus as a lymphoid organ.  
(b) Name the cells that are released from the above mentioned gland. Mention how they help in immunity.**

Ans. Immature lymphocyte differentiate into , (mature) lymphocyte in thymus =  $\frac{1}{2} + \frac{1}{2}$

T-lymphocyte =  $\frac{1}{2}$

These T-cells help B-cells to produce antibodies / takes part in immunity =  $\frac{1}{2}$

[2 marks]

**12. Explain the work carried out by Cohen and Boyer that contributed immensely in biotechnology.**

Ans. Cohen and Boyer isolated the antibiotic resistant gene , from the plasmid of a bacterium that was resistant to the antibiotic drug , and then linked this gene with the plasmid of *Salmonella typhimurium*, construction of artificial recombinant DNA molecule.  
=  $\frac{1}{2} \times 4$

[2 marks]

**13 Why do clown fish and sea anemone pair up ? What is this relationship called ?**

Ans. Clown fish gets protection from its predators by moving around the stinging tentacles of the sea anemone = 1

The sea anemone is neither helped or harmed by the interaction with the fish =  $\frac{1}{2}$

Commensalism =  $\frac{1}{2}$

[2 marks]

**14 (a) State the difference between meiocyte and gamete with respect to chromosome number.**

**(b) Why is a whiptail lizard referred to as parthenogenetic ?**

Ans. (a) Meiocyte - diploid /  $2n = \frac{1}{2}$

Gamete - haploid /  $n = \frac{1}{2}$

(b) It is a female and gives rise to new female reptile without fertilisation //  
because it develops from unfertilised egg = 1

[1 + 1 = 2 marks]

**15. Name the plant source of the drug popularly called “smack”. How does it affect the body of the abuser ?**

**OR**

**Why is *Rhizobium* categorized as a ‘symbiotic bacterium’ ? How does it act as a biofertiliser?**

Ans. (Poppy) *Papaver somniferum* = 1

Depressant / slows down body functions = 1

[2 marks]

**OR**

(*Rhizobium* is a symbiotic bacteria ) living in the root nodule of leguminous plants ,  
it fixes atmospheric nitrogen into organic forms to be used by plants =  $\frac{1}{2} + \frac{1}{2}$

It is a biofertilizer as it is a living organism that enriches nutrient content of the plant  
/ soil = 1

[2 marks]

**16. (a) State the role of DNA ligase in biotechnology.**

**(b) What happens when *Meloidogyne incognitia* consumes cells with RNAi gene ?**

Ans. (a) Linking of DNA fragment is done by DNA ligase / linking of Okazaki fragments  
or discontinuous synthesis fragments / linking of desired gene with plasmid to  
form recombinant DNA. **Any one** = 1

(b) Specific mRNA of the nematode silenced , parasite dies. =  $\frac{1}{2} + \frac{1}{2}$

[1 + 1 = 2 marks]

**17. Some organisms suspend their metabolic activities to survive in unfavourable conditions. Explain with the help of any four examples.**

Ans. Any four examples with their relevant conditions under which they suspend their  
metabolic activities such as polar bear - hibernation / during winter ,

Snails / fishes - aestivation / during summer , some species of zooplankton - diapause ,

Seeds of higher plants / spores of bacteria / fungi - dormancy /

Cyst formation as in case of amoeba =  $\frac{1}{2} \times 4$

[2 marks]

18. (a) Name the Protozoan parasite that causes amoebic dysentery in humans.  
(b) Mention two diagnostic symptoms of the disease.  
(c) How is this disease transmitted to others ?

Ans. (a) *Entamoeba histolytica* =  $\frac{1}{2}$

(b) Symptoms : constipation , abdominal pain , stools with mucus and blood clot  
(*Any Two*) =  $\frac{1}{2} + \frac{1}{2}$

(c) Contaminated food / water =  $\frac{1}{2}$

[2 marks]

### SECTION-C

*Q. Nos. 19 - 27 are of three marks each*

19. It is established that RNA is the first genetic material. Explain giving three reasons.

OR

- (a) Name the enzyme responsible for the transcription of tRNA and the amino acid the initiator tRNA gets linked with.  
(b) Explain the role of initiator tRNA in initiation of protein synthesis.

Ans. Processes like metabolism , translation , splicing evolved around RNA ,

RNA is reactive and catalyses reaction.

In some virus it is the hereditary material.

It is so unstable and hence would have mutated to lead to evolution. (*Any three*) =  $1 \times 3$

OR

(a) RNA polymerase III , Methionine =  $\frac{1}{2} + \frac{1}{2}$

(b) This tRNA (charged with amino acid Methionine) reaches the smaller subunit of ribosome, with its anticodon UAC recognises the codon AUG on mRNA and binds by forming complementary base pairs , leaves the amino acid , initiating protein synthesis = 2

[3 marks]

**20. State the theory of Biogenesis. How does Miller's experiment support this theory ?**

Ans. Biogenesis - A living organism arises from another living organism. =  $\frac{1}{2}$

Miller's experiment - An electric discharge, was created in a closed flask containing  $\text{CH}_4$  -  $\text{H}_2$  -  $\text{NH}_3$ , and water vapour at  $800^\circ\text{C}$ , which resulted in the formation of amino acids, supports chemical evolution. =  $\frac{1}{2} \times 5 = 2\frac{1}{2}$

// Miller's experiment does not support Theory of Biogenesis it supports chemical evolution. =  $2\frac{1}{2}$

[3 marks]

**21. Name the two different categories of microbes naturally occurring in sewage water. Explain their role in cleaning sewage water into usable water.**

Ans. Aerobic and anaerobic // fungi, bacteria =  $\frac{1}{2} \times 2$

(After primary treatment) growth of aerobic microbes into aeration tanks reduces BOD // consumes organic matter, Anaerobic bacteria decomposes the sludge (in the anaerobic sludge digesters) forming biogas etc. =  $1 + 1$

[3 marks]

**22. Write the function of each one of the following :**

(a) (Oviducal) Fimbriae

(b) Coleoptile

(c) Oxytocin

Ans. (a) Collection of ovum released by ovary

(b) Protects the plumule of the monocot embryo

(c) Causes uterine contraction for parturition / promotes milk ejection =  $1 \times 3$

[3 marks]

**23 Name the genes responsible for making Bt cotton plants resistant to bollworm attack. How do such plants attain resistance against bollworm attacks ? Explain.**

Ans. Bt cotton has cry IAc / cry II Ab gene, produces crystals of protoxins. When bollworm bites the cotton fruits, it consumes the toxic insecticidal protein, In its gut it is activated by the alkaline pH - binds to mid gut epithelial cells, lysis, swelling - death of the insect =  $\frac{1}{2} \times 6$

[3 marks]

**24. Study a part of the life cycle of malarial parasite given below. Answer the questions that follow:**

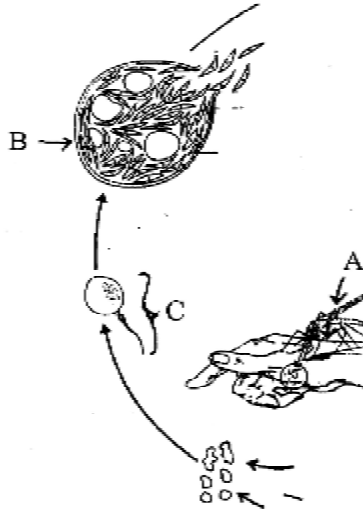

- (a) Mention the roles of 'A' in the life cycle of the malarial parasite.
- (b) Name the event 'C' and the organ where this event occurs.
- (c) Identify the organ 'B' and name the cells being released from it.

Ans. (a) 'A' - Gametocytes of Plasmodium enter the mosquito when it bites a malaria patient and takes the blood meal. = 1

(b) 'C' - Fertilization, intestine of the mosquito = 1/2 + 1/2

(c) 'B' - Salivary gland of the female Anopheles mosquito, Sporozoites of Plasmodium = 1/2 + 1/2

[3 marks]

25. Given below is the representation of amino acid composition of the relevant translated portion of b-chain of haemoglobin, related to the shape of human red blood cells.

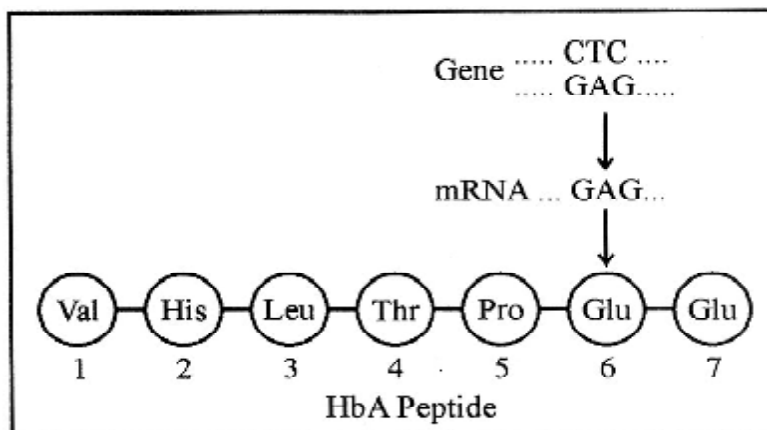

- (a) Is this representation indicating a normal human or a sufferer from certain related genetic disease ? Give reason in support of your answer.
- (b) What difference would be noticed in the phenotype of the normal and the sufferer related to this gene ?
- (c) Who are likely to suffer more from the defect related to the gene represented – the males, the females or both males and females equally ? And why ?

Ans. (a) This representation (HbA peptide) indicates a normal human , because the Glutamic Acid in the sixth position is not substituted by Valine. =  $\frac{1}{2} + \frac{1}{2}$

(b) The sufferer's RBCs become elongated and sickle shaped as compared to the normal biconcave RBCs = 1

(c) Both males and females are likely to suffer from the disease equally , as this is not a sex linked disease / It is an autosomal linked recessive trait. =  $\frac{1}{2} + \frac{1}{2}$

[3 marks]

26. By the end of 2002 the public transport of Delhi switched over to a new fuel. Name the fuel. Why is this fuel considered better ? Explain.

Ans. CNG / Compressed Natural Gas = 1

It burns more efficiently unlike diesel or petrol , very little of it is left unburnt , cannot be adulterated , cheaper than petrol or diesel =  $\frac{1}{2} \times 4$

[3 marks]

27. Draw a schematic sketch of pBR 322 plasmid and label the following in it:

- (a) Any two restriction sites.
- (b) Ori and rop genes.
- (c) An antibiotic resistant gene.

Ans.

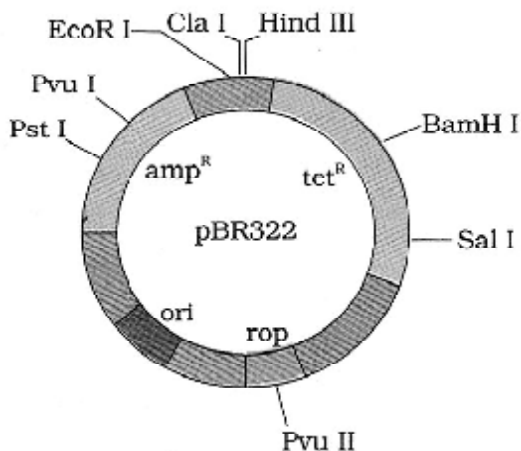



- (a) Pst I / Pvu I / EcoR I / Cla I / Hind III / BamH I / Sal I / Pvu II  
(Any Two)  $\frac{1}{2} + \frac{1}{2} = 1$
- (b) ori , rop =  $\frac{1}{2} + \frac{1}{2}$
- (c) amp<sup>R</sup> / tet<sup>R</sup> = 1

[3 marks]

### SECTION -D

*Q. Nos. 28 - 30 are of five marks each*

28. Explain the carbon cycle with the help of a simplified model.

OR

Explain how does:

- (a) a primary succession start on a bare rock and reach a climax community ?
- (b) the algal bloom eventually choke the waterbody in an industrial area ?

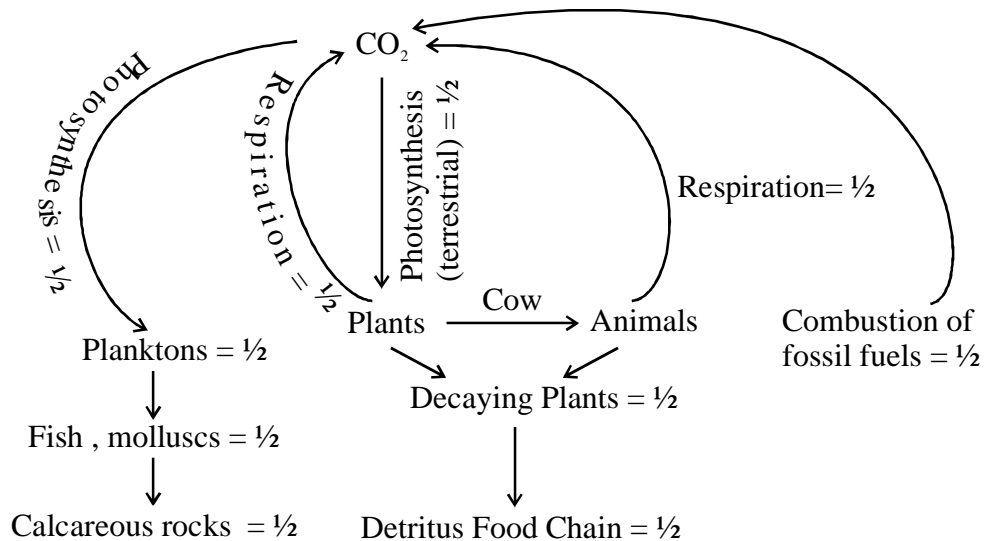

OR

- (a) Lichens on a bare rock , acids to dissolve rock , soil formation - bryophyte to hold the soil , retention of water - grass , scrubs and trees =  $\frac{1}{2} \times 5 = 2\frac{1}{2}$
- (b) Effluents from the industry , minerals stimulate algal growth , depletion of oxygen content , death of other aquatic life , lake is spoilt fully / dead lake / Eutrophication =  $\frac{1}{2} \times 5 = 2\frac{1}{2}$

[ $2\frac{1}{2} + 2\frac{1}{2} = 5$  marks]

29. The following is the illustration of the sequence of ovarian events (a - i) in a human female.

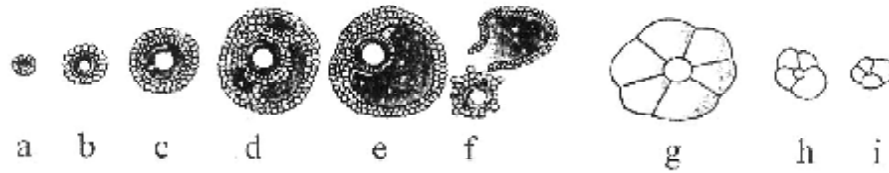

- (i) Identify the figure that illustrates ovulation and mention the stage of oogenesis it represents.
- (ii) Name the ovarian hormone and the pituitary hormone that have caused the above mentioned event.
- (iii) Explain the changes that occur in the uterus simultaneously in anticipation.
- (iv) Write the difference between 'c' and 'h'
- (v) Draw a labelled sketch of the structure of a human ovum prior to fertilization.

OR

How does the megaspore mother cell develop into 7-celled, 8 nucleate embryo sac in an angiosperm? Draw a labelled diagram of a mature embryo sac.

- Ans. (i) f, secondary oocyte =  $\frac{1}{2} + \frac{1}{2}$
- (ii) estrogen, LH =  $\frac{1}{2} + \frac{1}{2}$
- (iii) Endometrium proliferate (glands become corkscrew shaped) highly vascularised, high regeneration anticipating implantation of the fertilized ovum. =  $\frac{1}{2} + \frac{1}{2}$
- (iv) 'c' is developing follicle while 'h' is regressing corpus luteum =  $\frac{1}{2} + \frac{1}{2}$

(v)

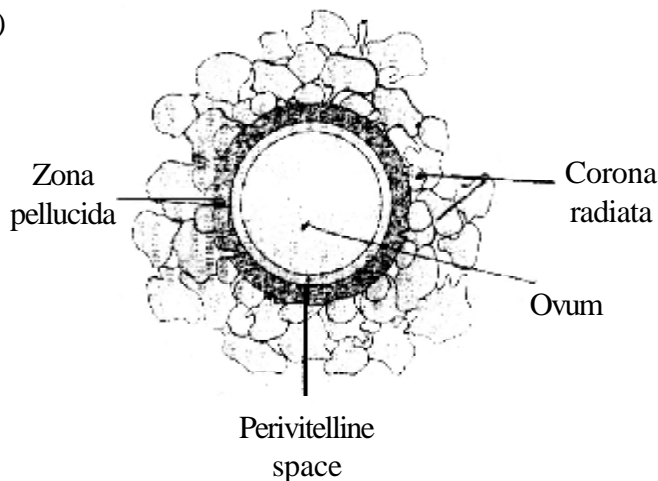

Any two labels =  $\frac{1}{2} + \frac{1}{2}$

OR

Megaspore mother cell undergoes meiosis producing one functional / viable megaspore , The functional megaspore divides mitotically to produce two nuclei which move to the opposite poles , each nucleus now divides twice forming four nuclei at each pole of which one nucleus from each pole moves to the centre forming two polar nuclei , walls are formed around 6 nuclei forming 3 antipodals at the chalazal end , and a 3 celled egg apparatus (having one egg cell and two synergids) at the micropylar end , the polar nuclei are present in the large central cell =  $\frac{1}{2} \times 6 = 3$

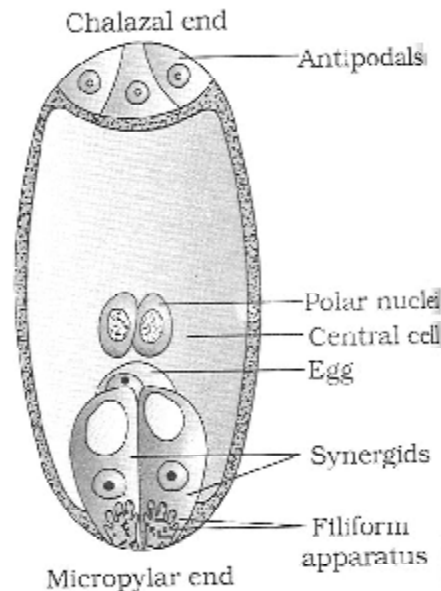

Any four correct labels =  $\frac{1}{2} \times 4 = 2$

[5 marks]

30. What is the inheritance pattern observed in the size of starch grains and seed shape of *Pisum sativum* ? Workout the monohybrid cross showing the above traits. How does this pattern of inheritance deviate from that of Mendelian law of dominance ?

OR

State the aim and describe Messelson and Stahl's experiment.

Ans. A single gene controls the size of the starch grains and the seed shape = 1

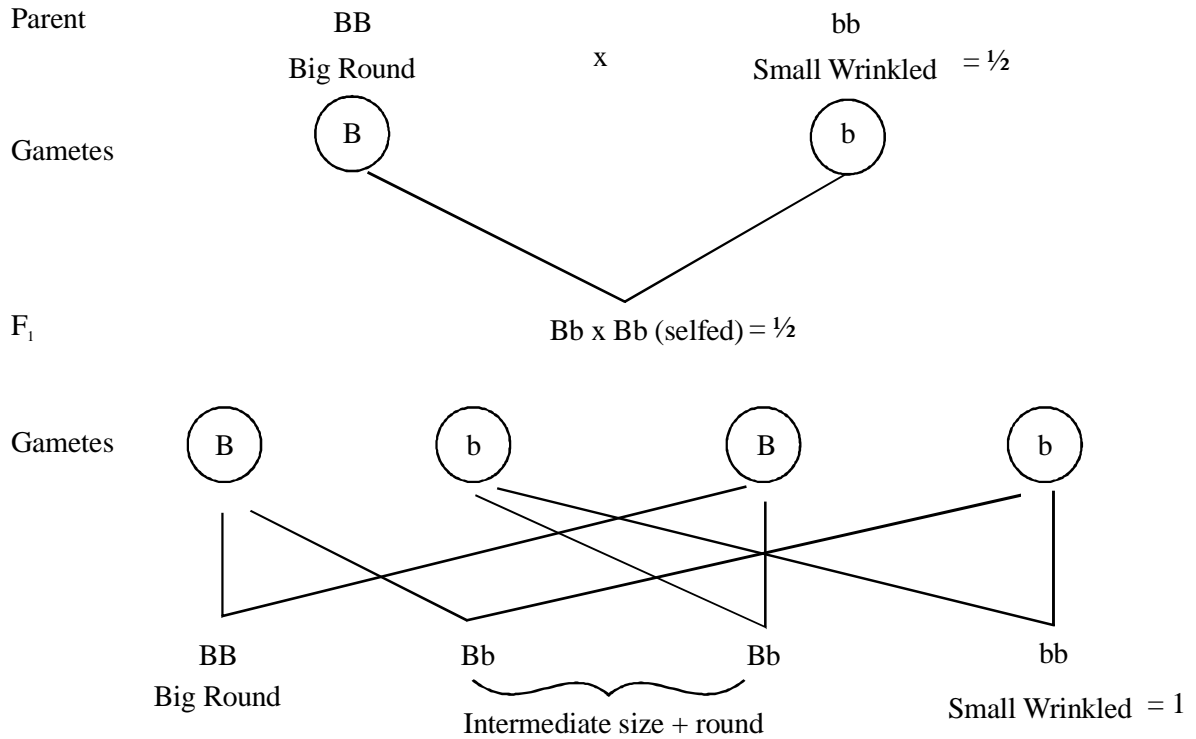

(Deviation from Mendelian Law of Dominance) : The trait of size of starch grain shows incomplete dominance. Hence in heterozygous condition the starch grain are of intermediate size = 1

The trait of seed shape follows Law of Dominance and the hybrid will show only dominant trait = 1

**OR**

The aim of the experiment done by Messelson and Stahl is to prove that DNA replication is semiconservative.=1

They grew *E. coli*, in  $^{15}\text{NH}_4\text{Cl}$  for many generations to get  $^{15}\text{N}$  incorporated into DNA , Then the cells are transferred into  $^{14}\text{NH}_4\text{Cl}$  , The extracted DNA are centrifuged in CsCl and measured to get their densities , DNA extracted from the culture after one generation (20 minutes) , showed intermediate hybrid density , DNA extracted after two generations (40 minutes) showed light DNA , and hybrid DNA =  $\frac{1}{2} \times 8 = 4 //$

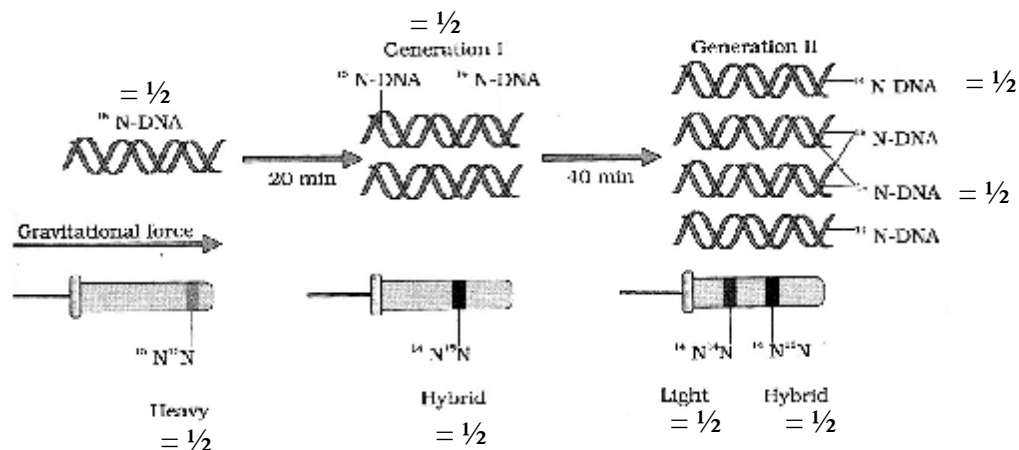

A correctly labelled diagrammatic representation in lieu of the explanation of experiment = 4

[5 marks]

## Question Paper Code 57/1

### SECTION – A

*Q. Nos. 1 - 8 are of one marks each*

1. Why is banana considered a good example of parthenocarpy?

Ans Formation of fruit without fertilisation / no formation of seeds = 1

[1 mark]

2. State two different roles of spleen in the human body.

Ans Spleen (is the secondary lymphoid organ that) stores lymphocytes, it filters microbes, acts as a reservoir to store erythrocytes (any two) =  $\frac{1}{2} + \frac{1}{2}$

[ $\frac{1}{2} + \frac{1}{2} = 1$  mark]

3. A garden pea plant produced axial white flowers. Another of the same species produced terminal violet flowers. Identify the dominant traits.

Ans Axial, violet flower =  $\frac{1}{2} + \frac{1}{2}$

[ $\frac{1}{2} + \frac{1}{2} = 1$  mark]

4. Why is it desirable to use unleaded petrol in vehicles fitted with catalytic converters?

Ans Lead in petrol inactivates the catalysts, harmful pollutants ( $\text{CO}$ , unburnt hydrocarbons, nitric oxide) are converted to lesser harmful pollutants ( $\text{CO}_2$ ,  $\text{H}_2\text{O}$ ,  $\text{N}_2$ ) =  $\frac{1}{2} + \frac{1}{2}$

[1 mark]

5. Where is acrosome present in humans? Write its function.

Ans On the sperm head =  $\frac{1}{2}$ , has enzymes to dissolve the follicles of ovum / facilitate entry of sperm nucleus for fertilisation / help the sperm enter into the cytoplasm of the ovum =  $\frac{1}{2}$

[ $\frac{1}{2}$  +  $\frac{1}{2}$  = 1 mark]

6. Write the name of the following :

(a) The most common species of bees suitable for apiculture

(b) An improved breed of chicken

Ans (a) *Apis indica* / *Apis mellifera* / *Apis dorsata* =  $\frac{1}{2}$ ,

(b) Leghorn / Rhode island red / Minorcha =  $\frac{1}{2}$

[ $\frac{1}{2}$  +  $\frac{1}{2}$  = 1 mark]

7. Comment on the similarity between the wing of a cockroach and the wing of a bird. What do you infer from the above, with reference to evolution ?

Ans Similar in function / analogous organs =  $\frac{1}{2}$ , convergent evolution =  $\frac{1}{2}$

[ $\frac{1}{2}$  +  $\frac{1}{2}$  = 1 mark]

8. Mention the role of cyanobacteria as a biofertiliser.

Ans (A biological organism) That fixes atmospheric nitrogen = 1

[1 mark]

### SECTION B

Q.Nos. 9 - 18 are of two marks each

9. (a) Draw a neat labelled diagram of a nucleosome.

(b) Mention what enables histones to acquire a positive charge.

Ans (a)

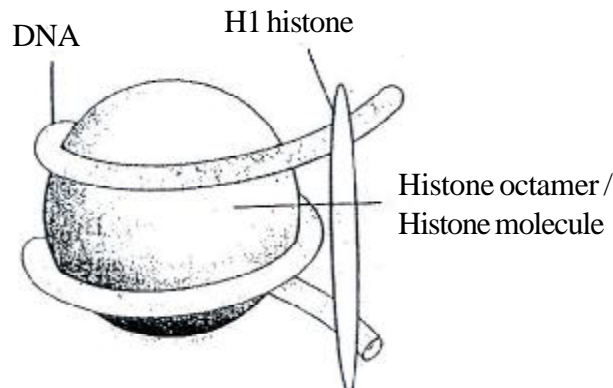

(any two correct labellings)

$\frac{1}{2} \times 2 = 1$

(b) Basic amino acid residues of lysines =  $\frac{1}{2}$ , arginines =  $\frac{1}{2}$

[1 +  $\frac{1}{2}$  +  $\frac{1}{2}$  = 2 marks]

**10. State one advantage and one disadvantage of cleistogamy.**

Ans Advantage - self pollination assured / seed production assured = 1

Disadvantage - Least variations / leading to inbreeding depression = 1

[1 + 1 = 2 marks]

**11. (a) Where do the signals for parturition originate from in humans ?**

**(b) Why is it important to feed the newborn babies on colostrum ?**

Ans (a) From the fully developed foetus / placenta / foetal ejection reflex (any one) = 1

(b) Contains (IgA) antibodies, to (passively) immunise the baby =  $\frac{1}{2}$  +  $\frac{1}{2}$

[1 + 1 = 2 marks]

**12. (a) A recombinant vector with a gene of interest inserted within the gene of  $\alpha$ -galactosidase enzyme, is introduced into a bacterium. Explain the method that would help in selection of recombinant colonies from non-recombinant ones.**

**(b) Why is this method of selection referred to as “insertional inactivation”?**

Ans (a) Bacteria is grown in a medium with chromogenic substrate, colonies formed show blue colour - no recombinants, no blue colour - presence of recombinants =  $\frac{1}{2} \times 3$

(b) Gene for the enzyme is inactivated by insertion =  $\frac{1}{2}$

[ $\frac{1}{2}$  +  $\frac{1}{2}$  = 2 marks]

**13. Explain brood parasitism with the help of an example.**

Ans Koel is a parasitic bird (which has lost the instinct to make its own nest to lay eggs) has evolved the technique of laying eggs in the nest of a crow = 1,

Its eggs bear resemblances to those of crow = 1

[1 + 1 = 2 marks]

**14. Give reasons for the following :**

**(a) The human testes are located outside the abdominal cavity.**

**(b) Some organisms like honey-bees are called parthenogenetic animals.**

Ans (a) To maintain the temperature (2-2.5°C) lower than the normal internal body temperature, is essential for spermatogenesis =  $\frac{1}{2}$  +  $\frac{1}{2}$

(b) They (drones/males) develop from unfertilised eggs = 1

[1 + 1 = 2 marks]

15. Name the plant source of *ganja*. How does it affect the body of the abuser?

OR

Name the two special types of lymphocytes in humans. How do they differ in their roles in immune response?

Ans *Cannabis sativa* / hemp plant = 1

Damages cardio vascular system = 1

[1 + 1 = 2 marks]

OR

B lymphocytes , T lymphocytes =  $\frac{1}{2}$  +  $\frac{1}{2}$

B-cells produce pathogen specific antibodies / humoral immune response =  $\frac{1}{2}$  ,

T-cells help the B-cells to produce antibodies / responsible for cell mediated immunity =  $\frac{1}{2}$

[1 +  $\frac{1}{2}$  +  $\frac{1}{2}$  = 2 marks]

16. (a) Mention the cause and the body system affected by ADA deficiency in humans.

(b) Name the vector used for transferring ADA-DNA into the recipient cells in humans. Name the recipient cells.

Ans (a) Defective gene not producing ADA , immune system is affected =  $\frac{1}{2}$  +  $\frac{1}{2}$

(b) A retroviral vector is used , recipient cells are lymphocytes =  $\frac{1}{2}$  +  $\frac{1}{2}$

[1 + 1 = 2 marks]

17. How did Ahmed Khan, plastic sacks manufacturer from Bangalore, solve the ever-increasing problem of accumulating plastic waste ?

Ans Collected plastic wastes - recycled - powdered - to form polyblend , blended with bitumen , used in road laying , increased road life by a factor of three / more durable =  $\frac{1}{2} \times 4$

[ $\frac{1}{2} \times 4$  = 2 marks]

18. Name the bacterium that causes typhoid. Mention two diagnostic symptoms. How is this disease transmitted to others ?

Ans *Salmonella typhi* =  $\frac{1}{2}$

Constipation , stomach pain , headache , weakness , loss of appetite , high fever (any two) =  $\frac{1}{2}$  +  $\frac{1}{2}$

The disease is transmitted through contaminated food / water =  $\frac{1}{2}$

[ $\frac{1}{2}$  + 1 +  $\frac{1}{2}$  = 2 marks]



**SECTION C**

**Q.Nos. 19 - 27 are of three marks each**

19. (a) **Explain the phenomena of multiple allelism and co-dominance taking ABO blood group as an example.**
- (b) **What is the phenotype of the following :**
- (i)  $I^A i$
- (ii)  $i i$

- Ans (a) One gene I has three alleles  $I^A$ ,  $I^B$  and  $i$  hence multiple allelism = 1
- We inherit any two of them. When the genotype is  $I^A I^B$ , the individual has AB blood group since both  $I^A$  and  $I^B$  equally influence the formation of Antigen A and B - Codominance = 1
- (b) (i)  $I^A i$  - A blood group =  $\frac{1}{2}$
- (ii)  $i i$  - O blood group =  $\frac{1}{2}$

[1 + 1 + 1 = 3 marks]

20. **How does industrial melanism support Darwin's theory of Natural Selection? Explain.**

- Ans Before industrial revolution-the environment was unpolluted the lichens on the barks of trees-pale, white winged moths could easily camouflage, while the dark winged were spotted out by the birds for food-hence they could not survive, After industrial revolution the lichens became dark (due to soot deposit), This favoured the dark winged moths while the white winged were picked by birds, The population of the former increased (naturally selected) =  $\frac{1}{2} \times 6$

[ $\frac{1}{2} \times 6 = 3$  marks]

21. (a) **What is the programme called that is involved in improving success rate of production of desired hybrid and herd size of cattle ?**
- (b) **Explain the method used for carrying this programme for cows.**

- Ans (a) Multiple ovulation embryo transfer method / MOET =  $\frac{1}{2}$
- (b) High milk yielding cow administered with FSH,  $\rightarrow$  6 to 8 eggs produced,  $\rightarrow$  inseminated artificially,  $\rightarrow$  fertilised eggs recovered non surgically at 32 cell stage,  $\rightarrow$  transferred to surrogate mother for further growth =  $\frac{1}{2} \times 5$

[ $\frac{1}{2} + 2\frac{1}{2} = 3$  marks]

22. **Explain the function of each of the following :**

- (a) **Coleorhiza**

(b) **Umbilical cord**

(c) **Germ pores**

Ans (a) Protects , the radicle of (monocot) embryo = 1

(b) Transports nutrients and respiratory gases and metabolic wastes to and from mother and foetus = 1

(c) Allow germination of pollen grain / formation of pollen tubes = 1

[1 + 1 + 1 = 3 marks]

**23. How is the amplification of a gene sample of interest carried out using Polymerase Chain Reaction (PCR)?**

Ans dsDNA is denatured at high temperature to unzip them , Annealing , using two sets of primers , amplification in the direction of 5'→3' using Taq polymerase, this enzyme is thermostable , (source is *Thermus aquaticus*) 1 billion times amplified in 30 cycles =  $\frac{1}{2} \times 6$

Labelled illustration to be evaluated in lieu of the explanation .

[ $\frac{1}{2} \times 6 = 3$  marks]

**24. Trace the life-cycle of malarial parasite in the human body when bitten by an infected female *Anopheles*.**

Ans Sporozoite of *Plasmodium* gets into human blood through the bite of female *Anopheles* mosquito, sporozoites reproduce asexually in liver cells , then they get into red blood cells , there they reproduce asexually and infect more blood cells , After a while they change into gametocytes , wait to be picked up by the mosquitoes =  $\frac{1}{2} \times 6$

[ $\frac{1}{2} \times 6 = 3$  marks]

**25. List the salient features of double helix structure of DNA.**

**OR**

**How are the structural genes activated in the lac operon in *E. coli* ?**

Ans DNA helix made up of two polynucleotide chains , each constituted by sugar-phosphate-bases , the chains are antiparallel in polarity (5'→3' and 3'→5'), the bases are linked with H-bonds , Adenine pair with Thymine with two H- bonds while Guanine pair with Cytosine with three H-bonds , Coiling of the chain are in right handed fashion , Pitch of the helix is 3.4nm and there are 10bp per turn , The plane of one base pair stacks over the other in a double helix (any six) =  $\frac{1}{2} \times 6$

[ $\frac{1}{2} \times 6 = 3$  marks]

**OR**

Lactose acts as the inducer , binds with repressor protein , frees operator gene , RNA polymerase freely moves over the structural genes, transcribing lac mRNA ,

which in turn produces the enzymes responsible for the digestion of lactose =  $\frac{1}{2} \times 6$

A complete labelled diagram depicting the concept can be evaluated in lieu of explanation

[3 marks]

- 26. Alien species are highly invasive and are a threat to indigenous species. Substantiate this statement with any three examples.**

Ans Nile perch introduced into lake Victoria in East Africa led to the extinction of Cichlid fish.

*Parthenium/Lantana/Eichhornia* invasive plants and pose a threat to indigenous species.

Introduction of African catfish (*Clarias gariepinus*) to aquaculture is a threat to Indian catfishes.

(any three) =  $1 \times 3$

[3 marks]

- 27. (a) Tobacco plants are damaged severely when infested with *Meloidogyne incognita*. Name and explain the strategy that is adopted to stop this infestation.**

**(b) Name the vector used for introducing the nematode specific gene in tobacco plant.**

Ans (a) Nematode specific gene introduced into host plant (using *Agrobacterium*), produced dsRNA, RNAi initiated, specific mRNA of the nematode silenced and parasite dies =  $\frac{1}{2} \times 4$

(b) *Agrobacterium tumifaciens* = 1

[ 2 + 1 = 3 marks]

## SECTION D

**Q.Nos. 28 - 30 are of five marks each**

- 28. (a) Taking one example each of habitat loss and fragmentation, explain how are the two responsible for biodiversity loss.**

**(b) Explain two different ways of biodiversity conservation.**

Ans (a) Habitat loss – Amazon rain forest destroyed for soyabean cultivation / for growing grass land for grazing cattle / colonisation of Pacific islands-extinction of 2000 species of native birds = 1

Fragmentation – By human activity – migratory birds and animals are affected = 1

b) Ex situ =  $\frac{1}{2}$ , Threatened organism are taken out from the natural habitat and

placed in special setting with care and protected = ½, eg. Zoological park / botanical garden / wild safari = ½

In situ = ½, Threatened organisms are conserved in their natural habitat = ½, eg. National parks / Biosphere reserves = ½

[2 + 3 = 5 marks]

**OR**

- (a) **What depletes ozone in the stratosphere? How does this affect human life?**
- (b) **Explain biomagnification of DDT in an aquatic food chain. How does it affect the bird population?**

Ans (a) Chloro fluorocarbons (CFC's) = 1

UV (B) damages DNA causing mutation, skin cancer, inflammation of cornea, cataract, aging of skin, snow blindness (any two) = ½ + ½

- (b) If DDT leaches from the agricultural field gets into the water body (the concentration is 0.003ppm), it gets into the food chain → zoo planktons (0.04 ppm), → small fish (0.05ppm) → large fish (2 ppm) → any fish eating bird (5ppm) // Concentration of DDT increases, along the food chain, reaching a high level in the top carnivore bird = 1½

DDT concentration disturbs  $Ca^{++}$  metabolism, → egg shells become thin, → premature breaking resulting in decline in bird population = 1½

[2 + 3 = 5 marks]

29. **The following is the illustration of the sequence of ovarian events “a” to “i” in a human female :**

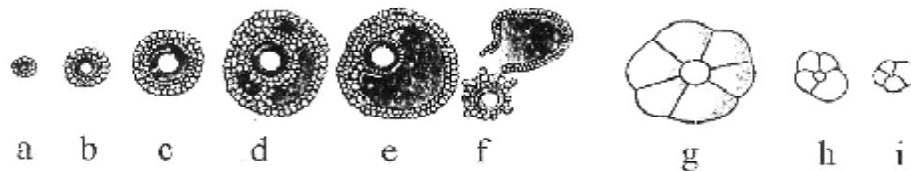

- (a) **Identify the figure that illustrates corpus luteum and name the pituitary hormone that influences its formation.**
- (b) **Specify the endocrine function of corpus luteum. How does it influence the uterus? Why is it essential?**
- (c) **What is the difference between “d” and “e”?**
- (d) **Draw a neat labelled sketch of Graafian follicle.**

- Ans (a) 'g' =  $\frac{1}{2}$  , Luteinising hormone (LH) =  $\frac{1}{2}$
- (b) Produces the hormone Progesterone, causes proliferation of the endometrium which gets highly vascularised, It is essential for the implantation of the fertilised ovum and to maintain the same during pregnancy =  $\frac{1}{2} \times 3$
- (c) "d" is the developing tertiary follicle =  $\frac{1}{2}$   
 "e" is the Graafian follicle =  $\frac{1}{2}$
- (d)

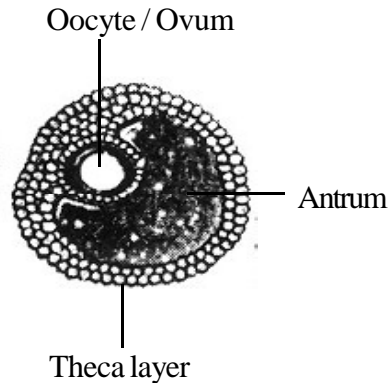

=  $\frac{1}{2} \times 3 = 1\frac{1}{2}$

[1 +  $1\frac{1}{2}$  + 1 +  $1\frac{1}{2}$  = 5 marks]

OR

- (a) **Why is fertilisation in an angiosperm referred to as double fertilisation? Mention the ploidy of the cells involved.**
- (b) **Draw a neat labelled sketch of L.S. of an endospermous monocot seed.**

- Ans (a) Fertilisation of haploid egg cell by one haploid male gamete , to form diploid zygote , is called syngamy =  $\frac{1}{2} \times 3$

Fertilisation of two (diploid) polar nuclei by the other haploid male gamete , to form triploid primary endosperm nucleus , is called triple fusion =  $\frac{1}{2} \times 3$

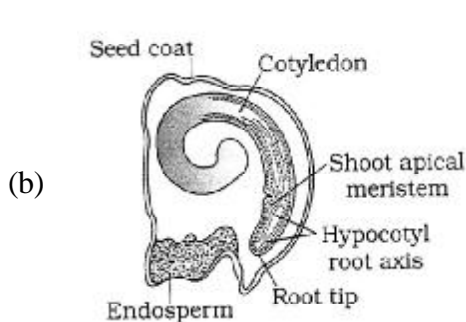

Figure I

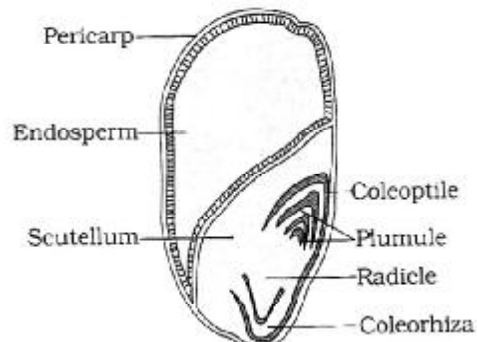

Figure II

(Any four labels including endosperm either from Fig. I or Fig. II)

$\frac{1}{2} \times 4 = 2$

[3 + 2 = 5 marks]

**30. Describe Frederick Griffith's experiment on *Streptococcus pneumoniae*. Discuss the conclusion he arrived at.**

Ans Griffith observed two strains of *Streptococcus pneumoniae* - smooth shiny colony called S type -virulent with capsule , The other R type rough colony non virulent =  $\frac{1}{2} + \frac{1}{2}$

Experiment :

Live S type → injected into mice → mice died =  $\frac{1}{2}$

Live R type → injected into mice → no infection =  $\frac{1}{2}$

Heat killed S type → injected into mice → no infection =  $\frac{1}{2}$

Heat killed S type + Live R type → injected into mice → mice died =  $\frac{1}{2}$

S type bacteria were isolated from the dead mice =  $\frac{1}{2}$

Griffith concluded that the genetic material of heat killed S type could transform R type into virulent S type =  $\frac{1}{2}$

He concluded that 'R' strain bacteria had been transformed by the heat - killed 'S' strain bacteria. = 1

[5 marks]

**OR**

- (a) Explain a monohybrid cross taking seed coat colour as a trait in *Pisum sativum*. Work out the cross upto  $F_2$  generation.
- (b) State the laws of inheritance that can be derived from such a cross.
- (c) How is the phenotypic ratio of  $F_2$  generation different in a dihybrid cross?

Ans (a)

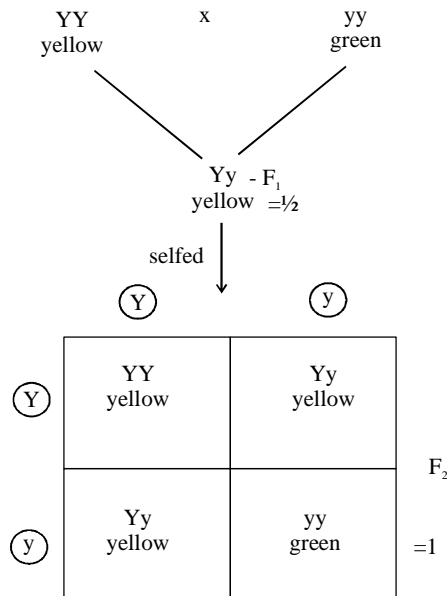

$F_2$  - Phenotypic ratio = 3:1

Genotypic ratio = 1:2:1 =  $\frac{1}{2}$

- b) Law of Dominance-In a contrasting pair of factors one member of the pair dominates (dominant) the other(recessive) =1

Law of Segregation-Factors or allele of pair segregate from each other so that a gamete receives only one of the two factors =1

- c) Phenotypic ratio of  $F_2$  in monohybrid cross is 3:1 whereas in a dihybrid cross the phenotypic ratio is 9:3:3:1 = 1

[2 + 2 + 1 = 5 marks]

# BIO-TECHNOLOGY

*Time allowed : 3 hours*

*Maximum Marks : 100*

## **General Instructions:**

- (i) *All questions are compulsory.*
- (ii) *There is no overall choice. However, an internal choice has been provided in one question of three marks and two questions of five marks. You have to attempt only one of the choices in such questions. Question paper contains four sections – A, B, C and D.*
- (iii) *Questions number 1 to 5 are very short answer questions, carrying 1 mark each.*
- (iv) *Questions number 6 to 15 are short answer questions, carrying 2 marks each.*
- (v) *Questions number 16 to 25 are also short answer questions, carrying 3 marks each.*
- (vi) *Questions number 26 to 28 are long answer questions, carrying 5 marks each.*
- (vii) *Use of calculators is not permitted. However, you may use log tables, if necessary.*

## **QUESTION PAPER CODE 99/1**

### **SECTION A**

1. In the field of bioinformatics, why is a single-letter code used to represent an amino acid rather than the older three letter one? 1
2. How is media sterilized in a large fermentor? 1
3. Burn victims are grafted with skin peels from other parts of their body rather than from a donor individual, why? 1
4. What is the significance of introducing mutations in microbial strains? 1
5. Name the two components of serum required for animal cell culture. 1



## SECTION - B

6. How are hydrophobic interactions created in proteins? 2
7. Give two reasons why different vectors are required for recombinant DNA technology? 2
8. Enumerate four types of molecular markers used for screening of plants. 2
9. On a large scale culturing of microbes, the sources of nutrients used in medium are different from that of a small scale culture. Why ? Name any two such sources of nutrients used for a large scale culture. 2
10. The 'in vitro' cultures of plant cells require several nutrients unlike intact plants. Why? Name two of these nutrients. 2
11. What are inverted microscopes and what are they useful for?
12. How is mass spectrometry useful in protein studies? Expand the terms 'MALDI' and 'ESI'. 2
13. For a PCR reaction, the following components were added; double stranded DNA (to be amplified), Taq polymerase, NTPs and double stranded primer in a suitable buffer. However, after several cycles in a PCR machine, amplification was low. Why? 2
14. A sequence of one letter symbols is given to you. How would you identify it as DNA, RNA or protein? 2
15. In the micro array technique, why is cDNA made instead of using the extracted mRNA ? Why are probes with different fluorescent colours used in a comparative hybridization assay? 2

## SECTION - C

16. In a variant of chymotrypsin, Asp 102 is replaced by Glu 102. Do you expect the enzyme to retain activity? Schematically indicate the role of the amino acid residues participating in catalysis. 3

17. An unusual plasmid has been discovered which has high transformation ability in *E. coli* and confers heat resistance to the host. Hence the host *E. coli* when transformed with this plasmid can grow at 50 °C. Schematically represent the various steps of cloning a foreign gene in this plasmid. How would you screen the transformed *E. coli* carrying this plasmid? 3
18. Enumerate any six secondary metabolites derived from plants. 3
19. Give two reasons why it is necessary to determine the kinetics of microbial growth? Which method of measuring microbial growth will give the most accurate representation of cell number? 3
20. With the help of a diagram depict a vector-mediated gene transfer method into plant cells. Is this method better than direct (vectorless) transfer methods? 3

**OR**

Why are transgenic plants considered useful? Name four transgenic plants along with their traits approved by the US Food and Drug Administration.

21. Plot a normal animal cell growth curve. Label its various phases of growth. With the help of a diagram, depict how cells appear in each phase of growth. 3
22. Subtilisin has been improved by protein engineering to serve as a component of laundry detergent. What are the features of this improvement and how have they been achieved? 3
23. With a diagram, depict the Southern hybridization technique. What is this technique used for? 3
24. What are the essential steps involved in the isolation of desired microbial products? Draw a flow sheet for the isolation of an intracellular microbial metabolite. 3
25. . Suggest the essential steps involved in raising a chimeric mouse using stem cell technology. 3

## SECTION - D

26. Name any five protein based products and their uses. 1 × 5

**OR**

What do you understand by the term 'nutraceutical' ? Name three sources of nutraceuticals and their uses.

27. How are genomic libraries different from cDNA libraries? Schematically depict the various steps involved in generating a genomic library. 5

28. What is 'BLAST' ? What is it useful for? Describe the principle involved in this analysis. 5

**OR**

What are the various types of DNA sequences which can be deposited into Databases? Suggest atleast three commonly used database retrieval tools and their uses.

## QUESTION PAPER CODE 99

### SECTION A

1. In DNA sequence readouts occasionally a S symbol appears. What does this mean? 1
2. Growth media for microbial growth is not always adjusted to pH 7.0. Why? 1
3. In heart bypass surgery, blood vessels from other parts of the patient are used to replace blocked coronary arteries instead of a donor. Explain. 1
4. Why are mutagens used for microbial strains? Name any one mutagen. 1
5. What is the main buffer system used in animal cell culture? 1

### SECTION B

6. How are hydrogen bonds formed in proteins? 2
7. Different types of vectors are required for recombinant DNA technology. Why ? 2

8. What is molecular breeding? Name any two molecular markers used in screening/ selection of plants. 2
9. Name the vessel used for holding microbial culture medium each for small scale and large scale culture, with a reason. 2
10. Why do '*in vitro*' cultures of plant cells require several nutrients unlike intact plants? Name any two such nutrients. 2
11. Animal cell cultures are grown in CO<sub>2</sub> incubators rather than in regular BODs. Why? 2
12. MALDI and ESI are used for the mass spectrometry of proteins. Expand these terms and indicate how they are useful for protein analysis. 2
13. In a parental dispute case, an RFLP analysis was performed on DNA obtained from the child, mother and paternal uncle (as the disputed father had died). Would the results be conclusive? Give reasons. 2
14. Write a 10-letter sequence each typical of DNA and protein. 2
15. What is FISH technique used for? How are fluorescent colours introduced into chromosomes? 2

### SECTION C

16. Briefly indicate the steps involved in protein fingerprinting. Would you expect haemoglobin having Val substituting Glu at position 6 of beta chain to cause sickle celled RBCs? 3
17. An unusual plasmid has been discovered which has high transformation ability in *E. coli* and confers heat resistance to the host. Hence the host when transformed can safely grow at 45°C. Schematically indicate the various steps of cloning a foreign gene into this plasmid. How would you screen the transformed *E. coli* carrying the plasmid? 3
18. Enumerate six secondary metabolites derived from plants being produced commercially. 3

19. In a microbial culture under going balanced growth, how is the specific growth rate ' $\mu$ ' calculated? Suggest an equation showing its relationship with cell concentration (gm/L) and time (hour). 3
20. Why are transgenic plants considered useful for humans? Name atleast three transgenic plants approved by the U.S. Food and Drug Administration. Mention any two concerns which ethical bodies have raised against the use of transgenic plants. 3

**OR**

Indicate various direct (vectorless) gene transfer methods used for plant cells. Name a vector used in plant biotechnology.

21. What are the crucial factors affecting the techno-commercial feasibility of the scale-up techniques used in animal cell culture? 3
22. Schematically depict how a protein can be engineered to have desired amino acids. 3
23. Describe the dideoxy sequencing technique with the help of suitable flow chart and structures. 3
24. What are the essential steps used in isolation of microbial products? Draw the flow chart of the isolation of an extracellular microbial metabolite citing an example. 3
25. What are monoclonal antibodies (MAbs) ? Suggest any one application of MAbs. 3

**SECTION D**

26. Describe briefly five protein based products with their uses. 5

**OR**

What is meant by the Biological value of proteins? How do branched chain amino acids help athletes to protect their existing mass and improve their performance?

27. Expand 'BLAST'. What is this tool used for? Differentiate between homologous and paralogous sequences. 5

**OR**

Do you think 0.2% difference in DNA sequence between human beings is enough to make each individual unique? What is the molecular nature of such variations? Are these variations associated with some diseases? Name one such disease. 5

28. How are genomic libraries different from cDNA libraries ? Schematically depict the various steps involved in generating a cDNA library. 5

## Marking Scheme — Biotechnology

### *General Instructions*

1. All questions are compulsory.
2. There is no overall Choice. However, an internal choice has been provided in one question of three marks and two questions of five marks. You have to attempt only one of the choices in such questions. Question paper contains four sections - A, B, C and D.
3. Questions number 1 to 5 are very short answer questions, carrying 1 mark each.
4. Questions number 6 to 15 are very short answer questions, carrying 2 marks each.
5. Questions number 16 to 25 are also short answer questions, carrying 3 marks each.
6. Questions number 26 to 28 are long answer questions, carrying 5 marks each.
7. Use of calculators is not permitted. However, you may use log tables, if necessary.
8. As per orders of the Hon'ble Supreme Court, the candidates would now be permitted to obtain photocopy of the Answer Book on request on payment of the prescribed fee. All examiners/Head Examiners are once again reminded that they must ensure that evaluation is carried out strictly as per value points for each answer as given in the marking Scheme.

QUESTION PAPER CODE 99/1

### **EXPECTED ANSWERS/VALUE POINTS**

(Note that wherever page nos. appear the first set of numbers before slash refer to the old edition, after slash refer to the latest edition)

#### **SECTION A**

- |                                                                |   |
|----------------------------------------------------------------|---|
| 1. Large amount of sequence data can be stored for comparison. | 1 |
| 2. Passing steam through spargers.                             | 1 |
| 3. To prevent rejection of foreign tissue.                     | 1 |

4. To create variations/strain improvement. 1
5. Any two as listed on Pg.148 (eg. Hormones, vitamins, lipids, etc)  $\frac{1}{2} \times 2 = 1$

### SECTION B

6. Water forces non polar amino acid residues out of solution to minimize the surface of contact thus reducing the number of hydrogen bonds that are broken. 2
7. To enable use of various hosts (prokaryotic and eukaryotic) 1
- To carry variable insert sizes (Eg. BACs carry longer sized inserts than plasmids) 1
8. RAPD, VNTR, RFLP, microsatellites  $\frac{1}{2} \times 4 = 2$
- (molecular breeding has not been included in the revised text book so marks may be allotted accordingly.)
9. Small scale culture-synthetic or semi synthetic media containing peptone, beef extract, casein digest, etc.
- Large scale culture requires nutrients which are economical and of consistent quality and availability throughout the year like cereal grains, etc. Pg.101-102/85-86.  $1+1 = 2$
10. Culture of plant cells involve only certain plant parts.
- Their photosynthetic capacity is limited. 1
- Nutrients-casein hydrolysate, phosphate, amino-acids, etc. Pg.120/110 1
11. In inverted microscopes the objective is inverted. 1
- To observe cells at the bottom of a plate/flask. 1
12. MALDI: Matrix assisted laser desorption and ionization
- ESI : Electrospray lonisation  $\frac{1}{2} \times 2 = 1$
- Useful for structural information on proteins (Pg.25/45) 1
13. Primer being double stranded is wrong. Forward and reverse primers are required. 2
- Otherwise primers will anneal to each other.



14. DNA ----- G,A,T,C  
 RNA ----- G,A,U,C  
 Proteins ----- 20 symbols 2
15. mRNA is highly unstable. Hence cDNA copy is required for stability. 2  
 Red and green fluorescent labels are used, one colour for each sample so that differential expression can be determined. If fluorescence is yellow it indicates both green and red fluorescence is equal and present together.

### SECTION C

16. Asp and Glu are similar in having a carboxylate residue and replacement will not alter activity.  
 Charge relay system (Pg.13-14/35) 1+2=3
17. Selection of transformant is by growth at 50°C. Non transformants cannot grow at this elevated temperature. 1  
 Scheme for cloning a foreign gene (Pg.55/14) 2
18. Any six from pg.125/117-118  $\frac{1}{2} \times 6 = 3$
19. Any two ---- to determine specific growth rate/doubling time/best time to harvest metabolites, biomass. 2  
 Viable plate count 1
20. Vector mediated gene transfer by *Agrobacterium tumefaciens*  
 as on pg. 127/120.  $2\frac{1}{2}$   
 Yes, it is more efficient.  $\frac{1}{2}$

### OR

- For having beneficial traits (pg.128-129/122) 1  
 Any 4 examples  $\frac{1}{2} \times 4 = 2$

- |     |                                                                                                 |   |
|-----|-------------------------------------------------------------------------------------------------|---|
| 21. | Growth curve and cell appearances (pg.151/142-143)                                              | 3 |
| 22. | To replace Met that is susceptible to oxidation, in subtilisin a component of laundry detergent |   |
|     | Use Site Directed Mutagenesis to alter Met222 to Ala222 (Pg. 33/52)                             | 1 |
| 23. | Used to identify a specific DNA sequence/gene by using a probe                                  | 1 |
|     | Diagram and details (pg.62-63/20)                                                               | 2 |
| 24. | Steps as on pg. no. 1 09-1111 100                                                               |   |
|     | Flow chart for intracellular metabolites.                                                       | 3 |
| 25. | Chimeric Mouse (Diagram and explanation as on pgs. 159/151)                                     | 3 |

**SECTION D**

- |     |                              |         |
|-----|------------------------------|---------|
| 26. | Any 5 as on pg.28-291 47-48. | 1×5 = 5 |
|-----|------------------------------|---------|

**OR**

- |     |                                                                    |   |
|-----|--------------------------------------------------------------------|---|
|     | Nutritional proteins having pharmaceutical applications            | 2 |
|     | Whey, curds as on pg.30/49-50                                      | 3 |
| 27. | Genomic libraries represent all possible sequences and are larger. |   |
|     | cDNA library has all expressed gene sequences                      | 2 |
|     | Making library; details with diagram as on pg. 56-57/21            | 3 |
| 28. | Basic Local Alignment Search Tool                                  | 1 |
|     | Use---For finding relationships and homology between sequences     | 2 |
|     | Principle involved as on pg. 93/79                                 | 2 |

**OR**

- |  |                                                          |   |
|--|----------------------------------------------------------|---|
|  | Any 4 out of 6 on pg.91/77-78                            | 2 |
|  | Any 3 database retrieval tools with uses as on pg. 92/78 | 3 |

QUESTION PAPER CODE 99  
**EXPECTED ANSWERS/VALUE POINTS**

(Note that wherever page nos. appear the first set of numbers before slash refer to the old edition, after slash refer to the latest edition)

**SECTION A**

1. Stands for G or C base. 1
2. Microbes require variable pH for optimum growth, eg. Yeast grow at low pH. 1
3. To prevent foreign graft rejection. 1
4. Nitrosoguanidine etc./for strain improvement. 1
5. Bicarbonate/CO<sub>2</sub>. 1

**SECTION B**

6. Hydrogen bonds occur between a hydrogen atom between two electronegative atoms like oxygen and nitrogen. 1  
Eg. Between peptide bonds in a protein. 1
7. For growth in different hosts like prokaryotes, eucaryotes. 1  
To carry different sized inserts. 1
8. Plant breeding assisted by nucleic acid(molecular) markers. 1  
RAPD, VNTR, RFLP, microsatellites (any two) 1  
(molecular breeding has not been included in the revised text book so marks may be allotted accordingly.)
9. Small scale- baffle flasks/ conical flasks; Large scale-fermentors. 1  
Aeration/mixing. 1
10. Intact plants have photosynthetic abilities and can make complex molecules. 1  
Cultured cells have to be provided complex molecules like auxins, vitamins etc. 1

- |     |                                                                                                                                                                                                                  |        |
|-----|------------------------------------------------------------------------------------------------------------------------------------------------------------------------------------------------------------------|--------|
| 11. | Animal culture media have bicarbonate based buffers which require CO <sub>2</sub> and normal BODs do not have CO <sub>2</sub> .                                                                                  | 2      |
| 12. | MALDI- Matrix assisted laser desorption ionization; ESI- Electrospray ionization.<br>Proteins are not volatile; these methods generate charged volatile protein molecules for analysis in the mass spectrometer. | 1<br>1 |
| 13. | If the child's RFLPs are matched 50% with mother's then mother is confirmed. However the absence of the father's RFLPs cannot confirm paternity. Uncle will not be suitable.                                     | 2      |
| 14. | DNA will have mostly A, T, G, C (no U)<br>Protein will have any of the 20 one letter codes.                                                                                                                      | 1<br>1 |
| 15. | FISH technique is used for detecting target molecules by hybridization.<br>Nick translation technique is used to introduce fluorescent nucleotides.                                                              | 1<br>1 |

### SECTION C

- |     |                                                                                                                                                             |              |
|-----|-------------------------------------------------------------------------------------------------------------------------------------------------------------|--------------|
| 16. | Steps in protein fingerprinting pg. 15-16/36-37.<br>Yes, as charged amino acid is replaced with hydrophobic one.                                            | 2½<br>½      |
| 17. | Selection of transformant is by growth at 45°C. Non transformants cannot grow at this elevated temperature.<br>Scheme for cloning a foreign gene (Pg.55/14) | 1<br>2       |
| 18. | Any six from pg.125/117-118                                                                                                                                 | ½×6 = 3      |
| 19. | Derivation of equation relating $\mu$ with time and cell concentration, pg.107/93.                                                                          | 3            |
| 20. | Useful for providing vitamin etc.(golden rice)<br>Three examples as on pg.132/1 26.<br>Two concerns as on pg. 136/1 30-131.                                 | ½<br>1½<br>1 |

**OR**

Vectorless gene transfer methods as listed on pg. 128/121.	2
Vector based on <i>A.tumefaciens</i> .	1
21. Any three- Plant has to have GMP/materials used non corrosive and inert/cost effective/have license from approving authority for food grade and/or injectible products. Pg.23/43	3
22. Details of site directed mutation technique as on pg. 33 and 68/26-27.	3
23. Sequencing method details as on pg.64-65/23-25.	2
Structure of dideoxy nucleotide	1
24. Isolation of microbial products as on pg. 109-110/99-100	2
Flow chart for isolating extracellular metabolite - on pages as above.	1
25. Monoclonal antibodies are specific antibodies generated by the Hybridoma technique. Pg.155/1 47	1
Use of OKT3 antibodies in transplantation. Pg.156/ 148.	
26. Any five protein based products as on pg.28-29/47-48.	5
<b>OR</b>	
Biological value is the protein nitrogen retained after consuming proteins- pg. 34/54.	1
Role of branched chain amino acids pg.35/53.	
27. BLAST Basic local alignment search tool	1
Tool useful for comparing sequences based on programmes.	2
Differences between homologues and paralogues	2
<b>OR</b>	
0.2% difference does make an individual unique.	1
SNPs are the molecular nature of these variations as on pg.80-81/62-63	2
Diseases linked to SNPs, same pages as above.	2

28. Genomic libraries represent all possible sequences in a genome and are larger. 2
- cDNA library has all expressed gene sequences and are smaller. 3
- Steps in making cDNA library with diagram, pg.56/21-22 3

# INFORMATICS PRACTICES

*Time allowed : 3 hours*

*Maximum Marks : 70*

## **Instruction:**

- Please check that this question paper contains 8 printed pages.
- Code number given on the right hand side of the question paper should be written on the title page of the answer-book by the candidate.
- Please check that this question paper contains 7 questions.
- Please write down the serial number of the question before attempting it.
- 15 minutes time has been allotted to read this question paper. The question paper will be distributed at 10.15 a.m. From 10.15 a.m. to 10.30 a.m., the student will read the question paper only and not write any answer script during this period.

## **QUESTION PAPER CODE NO. 90/1**

### **SECTION A**

- 1 (a) Gyan Deep International School is planning to connect all computers, each spread over distance within 40 meters. Suggest an economical cable type having high-speed data transfer, which can be used to connect these computers. 1
- (b) Write examples of one proprietary and one Open Source Software. 1
- (c) Name two Indian Scripts included in UNICODE. 1
- (d) Name any two most popularly used search engines. 1
- (e) Mr. KavyeShastri, General Manager of Unite Nations Corporate recently discovered that the communication between his company's accounts office and HR office is extremely slow and signals drop quite frequently. These offices are 120 metres away from each other and connected by an Ethernet cable. 2
- (i) Suggest him a device, which can be installed in between the offices for smooth communication.
- (ii) What type of network is formed by having this kind of connectivity out of LAN, MAN and WAN?

- (f) Give one advantage and one disadvantage of using Star topology over Bus topology. 2
- (g) Identify Domain name and URL from the following: 2  
<http://www.helpingeachother.in/home/aboutus.htm>
2. (a) While making a Form in NetbeanS.MS. Jaya Laxminathan wants to display a list of countries to allow the users to select their own country. Suggest her to choose most appropriate control out of ListBox and ComboBox. 1
- (b) What is the purpose of break keyword while using Switch Case Statement? Illustrate with the help of an example. 1
- (c) Write the HTML tag used to include an image in a HTML Web Page. 1
- (d) Write HTML code for the following: 1  
 To provide hyperlink to a website "http://WWW.w3school.com"
- (e) What will be the content of jTextField1 after executing the following code (Assuming that the TextArea1 had no content before executing this code)? 2
- ```
for (inti=2; i=5; i++)
{
    jTextField1.setText (
        jTextField1.getText ( ) + " " +
        Integer.toString(i*i));
}
```
- (f) Which of the following unit measures the speed with which data can be, transmitted from one node to another node of a network? Also give the expansion of the suggested unit? 2
- (i) Mbps
- (ii) Kmph
- (iii) MGps
- (g) Write Java code that takes value for side of a square in jTextField1 and calculate area of it to be displayed in jTextField2. 2



3. (a) Write MySql command to display the list of existing databases. 1
- (b) Mr. William wants to remove all the rows from Inventory table to release the storage space, but he does not want to remove the structure of the table. What MySql statement should he use? 1
- (c) Give one difference between COMMIT and ROLLBACK commands used in MySql. 1
- (d) A Table FLIGHT has 4 rows and 2 columns and another table AIRHOSTESS has 3 rows and 4 columns. How many rows and columns will be there if we obtain the Cartesian product of these two tables? 1
- (e) Mr. Sondi created two tables with DEPTNO as Primary key in Table1 and Foreign Key in Table2. While inserting a row in Table2. Mr. Sondi is not able to enter a value in the column DEPTNO. What could be the possible reason for it? 2
- (f) Itemcode consists of 6 digits is stored in an integer type variable intltemcode. Mrs. Srinivas wants to store this Item code in a String type variable called strltemCode. Write appropriate Java statement(s) to help her performing the same. 2
- (g) Mr. Mittal is using a table with following columns 2
- Name, Class, Stream\_Id, Stream\_name**
- He needs to display names of students who have not been assigned any stream or have been assigned stream\_name that ends with "computers".
- He wrote the following command, which did not give the desired result.
- SELECT Name, Class FROM Students**
- WHERE Stream\_name=NULL OR Stream\_name="%computers";**
- Help Mr. Mittal to run the query by removing the error and write correct query.
4. (a) What message will be displayed after the execution of the following code? 2
- ```
Int Age=24, Relaxation=6;
IntModiAge=Age-Relaxation;
If (ModiAge<18)
```

```

        JOptionPane.showMessageDialog(Null, "NOT eligible");
else
        JOptionPane.showMessageDialog(Null, "Eligible");

```

- (b) Rewrite the following program code using a if statement: 2

```

int C = jComboBox1.getSelectedIndex( );
switch (C)
{
    case 0: FinalAmt = BillAmt; break;
    case 1: FinalAmt = 0.9*BillAmt; break;
    case 2: FinalAmt = 0.8*BillAmt; break;
    default: FinalAmt = BillAmt;
}

```

- (c) How many times the following while loop get executed? 1

```

int p=5;
int q=36;
while (p<=q)
{
    P+=6;
}

```

- (d) What will be displayed in JTextArea1 after executing the following statement? 1

```

jTextArea1, setText ("INDIA\nINCREDBLE\tINDIA");

```

- (e) What will be the values of variables 'm' and 'n' after the execution of the following code? 2

```

intm, n=0;
for (m=1;m<4;m++)
{

```

```

n+=m;

n--;

}

```

- (f) Given a string object named Salary having value as "55000" stored in it. Obtain the output of the following.

2

```

JOptionPane.showMessageDialog(null,
""+Salary.length()+Integer.parseInt (Salary)) ;

```

- (g) Anandraj is a programmer at EducoPathshala Enterprises. He created the following GUI in NetBeans. Help him to write code for the following.

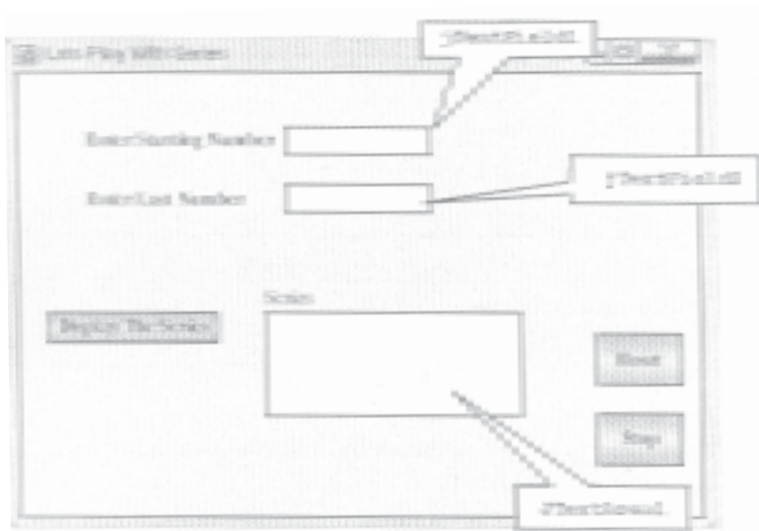

- (i) To display series of odd or even numbers (depending on Starting Number–jTextField1 is even or odd) in the JTextArea on the click of command button [Display The Series].

2

For example:

If the Start Number is 2 and Last Number is 10

Text Area Content will be

2 4 6 8 10

If the Start Number is 5 and Last Number is 10

Text Area Content will be

5 7 9 1 1

- (ii) To clear both the text fields and text area, on clicking [Reset] button 2
- (iii) To terminate the application on the click of [Stop] button. 1
- (Assume Suitable names for the various controls on the Form)
- 5 (a) What is the purpose of GROUP BY clause in MySQL? How is it different from ORDER BY clause? 2
- (b) **Table Hospital** has 4 rows and 5 columns. What is the Cardinality and Degree of this table? 1
- (c) Consider the Table Supplier given below. Write command in MySQL for (i) to (iv) and output for (v) to (vii)

Table **Supplier** :

Scode	Pname	Supname	Qty	City	Price
101	Coffee	Nestle	200	Kolkata	55.00
102	Biscuit	Hide & Seek	100	Delhi	10.00
103	Jam	Kissan	110	Kolkata	25.00
104	Maggi	Nestle	150	Mumbai	10.00
105	Chocolate	Cadbury	170	Delhi	25.00
106	Sauce	Maggi	56	Mumbai	55.00
107	Cake	Britannia	72	Delhi	10.00

- (i) To display names of the products, whose Pname starts with 'B' in ascending order of Price 1
- (ii) To display Supplier Code, Product Name and City of the products whose quantity is less than 150 1
- (iii) To count distinct City in the table. 1
- (iv) To insert a new row in the table Supplier. 1
- '110', 'Bournvita', 'ABC', 170, 'Delhi', 40.00
- (v) Select Pname from Supplier where Pname IN("Bread", "Maggi"); 1
- (vi) Select Count(Distinct(City)) from Supplier; 1
- (vii) Select max(price) from Supplier where City = "Kolkata"; 1

6. (a) Write MySQL command to create the Table Product including the Constraints.

2

Table: **PRODUCT**

Name of Column	Type	Size	Constraint
P_Id	Decimal	4	Primary Key
P_Name	Varchar	20	
P_Company	Varchar	20	
Price	Decimal	8	Not Null

6. (b) In a Database there are two tables:

Table **ITEM:**

Item_Code	Item_Name	Price
111	Refrigerator	90,000
222	Television	75,000
333	Computer	42,000
444	Washing Machine	27,000

Table **BRAND:**

Item_Code	Brand_Name
111	LG
222	Sony
333	HCL
444	IFB

Write MySQL queries for the following:

- (i) To display Item\_Code, Item\_Name and corresponding Brand\_Name of those Items, whose Price is between 20000 and 40000 (both values inclusive). 2
- (ii) To display Item\_code, Price and Brand\_Name of the item which has Item\_Name as "Computer". 2
- (iii) To increase the price of all the items by 10% 2

(c) Given below is a Table Patient.

<b>Name</b>	<b>P_No</b>	<b>Date_Admn</b>	<b>Doc No</b>
VimlaJain	P0001	2011-10-11	D201
IshitaKohli	P0012	2011-10-11	D506
Vijay Verma	P1002	2011-10-17	D201
Vijay Verma	P1567	2011-11-22	D233

(i) Identify Primary key in the table given above. 1

(ii) Write MySql query to add a column Department with data type varchar and size 30 in the table Patient. 1

7 (a) What social impact does e-Governance have on society? 1

(b) Write two important features of e-Business. Give two most commonly used e-Business sites. 2

(c) Mr. Anurag Das working as Manager in Vivian Enterprises wants to create a form in NetBeans to take various inputs from user. Choose appropriate controls from Label, TextBox, Radio Button, Check Box, ListBox, Combo Box and Command Button and write them in the third column: 2

<b>S.No.</b>	<b>Control used to</b>	<b>Control</b>
1.	Enter Name, Address and Salary	
2.	Select Gender (Male/Female)	
3.	Select Department from available List	
4.	Choose Hobby of Employee (Singing/Dancing/Skating/Swimming)	

**QUESTION PAPER CODE NO. 90**

**SECTION A**

- 1 (a) Raj Kamal International School is planning to connect all computers, each spread over distance within 45 meters. Suggest an economical cable type having high-speed data transfer, which can be used to connect these computers. 1
- (b) Name two Indian Scripts included in UNICODE. 1
- (c) Write examples of one Proprietary and one Open Source Software. 1
- (d) Name any two most popularly used internet browsers. 1
- (e) Ms. Rani Sen, General Manager of Global Nations Corporate recently discovered that the communication between her company's accounts office and HR office is extremely slow and signals drop quite frequently. These offices are 125 metres away from each other and connected by an Ethernet cable. 1
- (i) Suggest her a device, which can be installed in between the offices for smooth communication.
- (iii) What type of network is formed by having this kind of connectivity out of LAN, MAN and WAN?
- (f) Give an advantage of using Star topology over Bus topology. Show a network layout of Star topology to connect 5 computers. 2
- (g) Give suitable example of URL and Domain name 2
2. (a) While making a Form in Netbeans, Mr. Halihar Jha wants to display a list of countries to allow the users to select their own country. Suggest him to choose most appropriate control out of ListBox and ComboBox. 1
- (b) What is the purpose of break keyword while using Switch Case Statement? Illustrate with the help of an example. 1
- (c) Write the name HTML tag used to include numbered list in a HTML Web Page. 1
- (d) Write HTML code for the following: 1
- To provide hyperlink to a website "http://www.cbse.nic.in"

- (e) What will be the content of the `jTextArea1` after executing the following code (Assuming that the `jTextArea1` had no content before executing this code)? 2
- ```

for (int C=1; C=4; C++)
{
    jTextArea1.setText (
        jTextArea1.getText ( ) + " " +
        Integer.toString (C*C) ) ;
}

```
- (f) Which of the following units measures the speed with which data can be transmitted from one node to another node of a network? Also give the expansion of the suggested unit. 2
- (i) KMph
  - (ii) KMpl
  - (iii) Mbps
- (g) Write Java code that takes value for a number (n) in `jTextField1` and cube ( $n*n*n$ ) of it to be displayed in `jTextField2`. 2
- 3 (a) Write MySQL command to open an existing database. 1
- (b) Ms. Mirana wants to remove the entire content of a table "BACKUP" along-with its structure to release the storage space. What MySQL statement should she use? 1
- (c) Give one difference between ROLLBACK and COMMIT commands used in MySQL. 1
- (d) A table STUDENTS has 4 rows and 2 columns and another table TEACHER has 3 rows and 4 columns. How many rows and columns will be there if we obtain the Cartesian product of these two tables? 1
- (e) Mr. Sang hi created two tables with CITY as Primary Key in Table1 and Foreign Key in Table2. While inserting a row in Table2, Mr. Sanghi is not able to enter a value in the column CITY. What could be the possible reason for it? 2



- (f) Item code consisting of 5 digits is stored in an integer type variable `intItemCode`. Mr. Srikant wants to store this Item code in a String type variable called `strItemCode`. 2
- Write appropriate Java statement(s) to help her in performing the same.,
- (g) Mr. Janak is using a table with following columns: 2
- Name, Class, Course\_id, Course\_name
- He needs to display names of students, who have not been assigned any stream or have been assigned Course\_name that ends with 'economics'.
- He wrote the following command, which did not give hte desired result.
- ```
SELECT Name, Class FROM Students
WHERE Course name=NULL OR Course name= "%economics";
```
- Help Mr. Janak to run the query by removing the error and write the correct query.
4. (a) What message will be displayed after the executing of the following code? 2
- ```
int Age=64, Relaxation=4;
int ModiAge=Age-Relaxation;
if (ModiAge<60)
    JOptionPane.showMessageDialog(Null, "NOT Eligible")
else
    JOptionPane.showMessageDialog(Null. "Eligible")
```
- (b) Rewrite the following program code using a If statement: 2
- ```
int C=jComboBox1.getSelectedIndex ();
switch (C)
{
    case 0 : Amount=Bill;break;
    case 1 : Amount=0.9*Bill;break;
    case 2 : Amount=0.8*Bill;break;
    default : Amount=Bill;
}
```

- (c) How many times does the following while loop get executed? 1

```
int K=5i
int L=36i
while (K<=L)
{
    K+=6 ;
}
```

- (d) What will be displayed in JTextArea1 after executing the following statement? 1

```
JTextArea1, setText ("GREAT\nCOUNTRY\tINDIA");
```

- (e) What will be the values of variables 'm' and 'n' after the executing of the following code? 2

```
Int P,Q=Q
For (P=1;P<=4;P++)
{
    Q+=P
    Q--;
}
```

- (f) Given a string object named Pay having value as "68000" stored in it. Obtain the output of the following: 2

```
JOptionPane.showMessageDialog (null,
" " +Salary.length ( ) +Integer.parseInt (Salary));
```

- (g) Janav Raj is a programmer at Path Educo Enterprises. He created the following GUI in NetBeans. Help him to write code for the following:

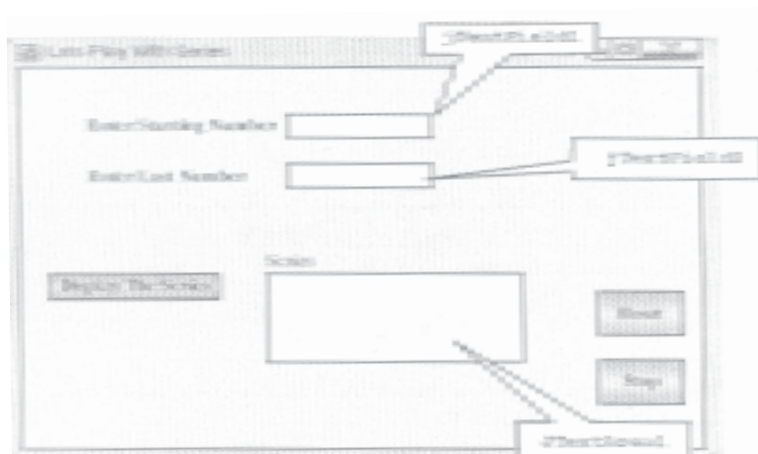

- (i) To display series of odd or even numbers (depending on Starting Number - jTextField1 is even or odd) in the jTextArea on the click of command button [Display The Series].

2

For example:

If the Start Number is 5 and Last Number is 11

Test Area Content will be

57911

If the Start Number is 2 and Last Number is 10

Text Area Content will be

246810

- (ii) To clear both the text fields and text area, on clicking [Reset] button.
- (iii) To terminate the application on the click of [Stop] button. (Assume Suitable names for the 11 various controls on the Form)

2

1

5. (a) What is the purpose of ORDER BY clause in MySQL? How is it different from GROUP BY clause?
- (b) Table SCHOOL has 4 rows and 5 columns. What is the Cardinality and Degree of this table?
- (c) Consider the Table SHOPPE given below. Write command in MySQL for (i) to (iv) and output for (v) to (vii).

2

Table **SHOPPE:**

Code	Item	Company	Qty	City	Price
102	Biscuit	Hide & Seek	100	Delhi	10.00
103	Jam	Kissan	110	Kolkata	25.00
101	Coffee	Nestle	200	Kolkata	55.00
106	Sauce	Maggi	56	Mumbai	55.00
107	Cake	Britannia	72	Delhi	10.00
104	Maggi	Nestle	150	Mumbai	10.00
105	Chocolate	Cadbury	170	Dehli	25.00

- (i) To display names of the items whose name starts with 'C' in ascending order of Price. 1
- (ii) To display Code, Item name and City of the products whose quantity is less than 100. 1
- (iii) To count distinct Company from the table. 1
- (iv) To insert a new row in the table Shoppe 1  

```
'110', 'Pizza', 'Papa Jones', 120, 'Kolkata', 50.0
```
- (v) Select Item from Shoppe where Item IN ("Jam", "Coffee"); 1
- (vi) Select Count (distinct (City)) from Shoppe; 1
- (vii) Select MIN (Qty) from Shoppe where City="Mumbai"; 1

6. (a) Write MySql command to create the Table STOCK including its Constraints. 2

**Table STOCK:**

Name of Column	Type	Size	Constraint
Id	Decimal	4	Primary Key
Name	Varchar	20	
Company	Varchar	20	
Price	Decimal	8	Not Null

(b) In a Database there are two tables: 2

**Table ITEM:**

ICode	Iname	Price
101	Television	75000
202	Computer	42000
303	Refrigerator	90000
404	Washing Machine	27000

**Table BRAND:**

<b>ICode</b>	<b>Brand</b>
101	Sony
202	HP
303	LG
404	IFB

Write Mysql queries for the following :

- (i) To display ICode, IName and corresponding Brand of those Items, whose Price is between 20000 and 45000 (both values inclusive). 2
  - (ii) To display ICode, Price and BName, of the item which has IName as "Television". 2
  - (iii) To increase the price of all Item by 15% 2
- (c) Given below is a Table Patient.

Name	P No	Date Admn	Doc No
VimlaJain	POO01	2011-10-11	0201
Ishita Kohli	P0012	2011-10-11	0506
Vijay Verma	P1002	2011-10-17	0201
Vijay Verma	P1567	2011-11-22	0233

- (i) Identify Primary key in the table given above. 1
  - (ii) Write MySQL query to add a column Department with data type varchar and size 30 in the table Patient. 1
7. (a) What social impact does e-Governance have on society? 1
- (b) Write two important features of e-Business. Give two most commonly used e-Business sites. 2
- (c) Mr. Anurag Das working as Manager in Vivian Enterprises wants to create a form in NetBeans to take various inputs from user. Choose appropriate controls from Label, TextBox, Radio Button, CheckBox, ListBox, ComboBox, and Command Button and write them in the third column: 2

<b>S.No.</b>	<b>Control used to</b>	<b>Control</b>
1.	Enter Name, Address and Salary	
2.	Select Gender (Male/Female)	
3.	Select Department from available list	
4.	Choose Hobby of Employee (Singing/Dancing/Skating/Swimming)	

## MARKING SCHEME — INFORMATICS PRACTICES

### General Instructions :

- Marking scheme is the final document for all references with regard to evaluation and cannot be altered under any circumstances
- The answers given in the marking scheme are SUGGESTIVE, Examiners are requested to award marks for all alternative correct Solutions/Answers conveying the similar meaning
- All programming questions have to be answered with respect to Java Language only
- In Java, ignore case sensitivity for identifiers (Variable/Functions/Structures/Class Names)
- In SQL related questions - both ways of text/character entries should be acceptable for Example: "AMAR" and 'amar' both are correct.
- In SQL related questions - semicolon should be ignored for terminating the SQL statements
- In SQL related questions, ignore case sensitivity.
- In SQL related questions, ignore column headers in outputs.

### QUESTION PAPER CODE 90/1

### EXPECTED ANSWERS

- 1 (a) Gyan Deep International School is planning to connect all computers, each spread over distance within 40 meters. Suggest an economical cable type having high-speed data transfer, which can be used to connect these computers.

1

Ans Coaxial cable

**OR**

UTP (Unshielded Twisted Pair)

**OR**

STP (Shielded Pair Cable)

*(1 mark for correct answer)*

(b) Write examples of one proprietary and one Open Source Software. 1

Ans **Proprietary software** : MS Office, Oracle, Windows, Photoshop

**Open Source Software** : Linux, Google Chrome OS, Android smart, GIMP, OpenOffice.org, Python, MySQL, Java,

**OR**

Any other correct answer for each type of software

*(1/2 mark for each correct answer)*

(c) Name two Indian Scripts included in UNICODE. 1

Ans Assamese, Bengali, Devanagari, Gujarati, Gurmukhi, Kannada, Malayalam, Oriya, Tamil and Telugu

**OR**

Any 2 Indian Scripts

*(1/2 mark for each correct answer)*

(d) Name any two most popularly used search engines. 1

Ans Google

Altavista

**OR**

Any 2 correct search engine names

*(1/2 mark for each correct answer)*

(e) Mr. KavyeShastri, General Manager of Unite Nations Corporate recently discovered that the communication between his company's accounts office and HR office is extremely slow and signals drop quite frequently. These offices are 120 metres away from each other and connected by an Ethernet cable. 2

(i) Suggest him a device, which can be installed in between the offices for smooth communication.

Ans Repeater

**OR**



Switch

Note: Router also to be accepted

*(1 mark for answer)*

- (ii) What type of network is formed by having this kind of connectivity out of LAN, MAN and WAN? 2

Ans LAN

**OR**

Local Area Network

*(1 mark for answer)*

- (f) Give one advantage and one disadvantage of using Star topology over Bus topology. 2

**Advantages**

More efficient

Faults can be diagnosed easily

**OR**

Any other advantage

**Disadvantages**

Long cable length required

Cost of implementing layout is high

**OR**

Any other disadvantage

*(1 mark for advantage)*

*(1 mark for disadvantage)*

- (g) Identify Domain name and URL from the following: 2

<http://www.helpingeachother.in/home/aboutus.htm>

Ans **Domain Name:** www.helpingeachother.in

**URL:** <http://www.heIPingeaChother.in/home/aboutus.htm>

*(1 mark for URL)*

*(1 mark for Domain Name)*

2. (a) While making a Form in NetbeanS.MS. Jaya Laxminathan wants to display a list of countries to allow the users to select their own country. Suggest her to choose most appropriate control out of ListBox and ComboBox. 1

Ans. ListBox

**OR**

ComboBox

*(1 mark for any correct answer)*

- (b) What is the purpose of break keyword while using Switch Case Statement? Illustrate with the help of an example. 1

Ans Break stops the flow of logic within the switch statement and the statement immediately following the switch is executed.

**OR**

Break statement prevents "fall through" in the switch statement

**Example: .**

```
switch (a)
{
case 1: a++; break;
case 2: b++;
case 3: c++; break;
}
```

**OR**

Any other example of switch statement

*(1/2 mark for purpose of break)*

*(1/2 mark for correct switch statement example)*

(c) Write the HTML tag used to include an image in a HTML Web Page. 1

Ans <IMG>

OR

Mentioning IMAGE tag

*(1 mark for correct HTML TAG)*

(d) Write HTML code for the following: 1

To provide hyperlink to a website "http://WWW.w3school.com"

Ans <AHREF= "http://www.w3school.com.." > w3school </A>

*(1 mark for correct HTML TAG)*

OR

*(1 mark if any part of Q2 has been attempted correctly)*

OR

*(1 mark for attempting the question)*

(e) What will be the content of jTextArea1 after executing the following code (Assuming that the TextArea1 had no content before executing this code)? 2

```
for (inti=2; i=5; i++)
{
jTextArea1.setText (
jTextArea1.getText( ) + " " +Integer.toString(i*i));
}
```

Ans Refer Note

Note:

*(2 marks to be awarded for anyone of the following answers:*

1. **Syntax Error**
2. **Program will not compile**
3. **No output)**

**OR**

*(2 marks to be awarded if operator is changed and any output is written)*

- (f) Which of the following unit measures the speed with which data can be, transmitted from one node to another node of a network? Also give the expansion of the suggested unit? 2
- (i) Mbps
  - (ii) Kmph
  - (iii) MGps

Ans. **Mega bits per second**

(Note :Mega bytes per second may also be accepted)

*(1 mark for identifying unit of measure)*

*(1 mark for expansion)*

- (g) Write Java code that takes value for side of a square in jTextField1 and calculate area of it to be displayed in jTextField2. 2

Ans. `float a;`

```
a=Float.parseFloat(jTextField1.getText( ) ) ;  
jTextField2.setText (" "+a*a) ;
```

**OR**

Any other equivalent code

Note: a can be taken as int or double

*(1 mark for getting the value from jTextField1)*

*(1/2 mark for calculating square)*

*(1/2 mark for displaying in jTextField2)*

*Note: - Do not deduct marks for error in formula*

3. (a) Write MySQL command to display the list of existing databases. 1

Ans show databases;

*(1 mark for the answer)*

*(1/2 mark for writing only SHOW keyword)*

(b) Mr. William wants to remove all the rows from Inventory table to release the storage space, but he does not want to remove the structure of the table. What MySQL statement should he use? 1

Ans DELETE FROM INVENTORY

OR

DELETE FROM

*(1 mark for the answer)*

*(1/2 mark for mentioning only DELETE)*

(c) Give one difference between COMMIT and ROLLBACK commands used in MySQL. 1

Ans **COMMIT** statement saves all changes made during the transaction to the database. **ROLLBACK** aborts transaction and does not save any of the changes made to the database during the transaction.

**OR**

Any other equivalent answer/example

*(1/2 mark for COMMIT)*

*(1/2 mark for ROLLBACK)*

(d) A Table FLIGHT has 4 rows and 2 columns and another table AIRHOSTESS has 3 rows and 4 columns. How many rows and columns will be there if we obtain the Cartesian product of these two tables? 1

Ans 12 rows, 6 columns

**OR**

12, 6

**OR**

12 6

*(1/2 mark for rows)*

*(1/2 mark for columns)*

- (e) Mr. Sondi created two tables with DEPTNO as Primary key in Table1 and Foreign Key in Table2. While inserting a row in Table2. Mr. Sondi is not able to enter a value in the column DEPTNO. What could be the possible reason for it?

2

Ans. Referential integrity enforcement ensures that value must exist in referred table for successful insertion in the dependent table.

**OR**

Mentioning Primary key - Foreign key relationship

**OR**

Any other answer that illustrates the Primary key - Foreign key relationship concept

*(2 marks for correct answer)*

- (f) Itemcode consists of 6 digits is stored in an integer type variable intItemcode. Mrs. Sriniwas wants to store this Item code in a String type variable called strItemCode. Write appropriate Java statement(s) to help her performing the same.

2

Ans. `String strItemCode = Integer.toString( intItemcode)`

**OR**

Any other equivalent statement

NOTE: String object need not be declared

*(2 marks for correct answer)*

*(1 mark if the variable names has been changed)*

- (g) Mr. Mittal is using a table with following columns

2

Name, Class, Stream\_id, Stream\_name

He needs to display names of students who have not been assigned any stream or have been assigned stream\_name that ends with "computers". He wrote the following command, which did not give the desired result.

```
SELECT Name, Class FROM Students
```

```
WHERE Stream_name=NULL OR Stream_name="%computers";
```

Help Mr. Mittal to run the query by removing the error and write correct query.

Ans. SELECT Name, Class

FROM Students

WHERE Stream\_name IS NULL OR Stream\_name like "%computers";

*(2 marks for correct query)*

**OR**

*(1 mark for IS NULL)*

*(1 mark for LIKE)*

*(Award 1½ mark if only errors are identified)*

4. (a) What message will be displayed after the execution of the following code? 2

```
Int Age=24, Relaxation=6;
```

```
IntModiAge=Age-Relaxation;
```

```
If (ModiAge<18)
```

```
jOptionPane.showMessageDialog(Null, "NOT eligible");
```

```
else
```

```
jOptionPane.showMessageDialog(Null, "Eligible");
```

Ans. Eligible

OR

Syntax Error

OR

Error

OR

No output

*(2 marks for any answer mentioned above)*

- (b) Rewrite the following program code using a if statement: 2

```
int C = jComboBox1.getSelectedIndex( );
```

```
switch (C)
```

```

{
    case 0: FinalAmt = BillAmt; break;
    case 1: FinalAmt = 0.9*BillAmt; break;
    case 2: FinalAmt = 0.8*BillAmt; break;
    default: FinalAmt = BillAmt;
}

```

Ans. `int C = jComboBox1.getSelectedIndex( );`

```

if (C==0)
FinalAmt = BillAmt;
else if(C= =1)
FinalAmt=0.9*BillAmt;
else if(C= =2)
FinalAmt=0.8*BillAmt;
else
FinalAmt= BillAmt;

```

**OR**

```

int C = jComboBox1.getSelectedIndex( );
if (C= =0)
FinalAmt = BillAmt;
if (C= =1)
FinalAmt=0.9*BillAmt;
if (C= =2)
FinalAmt=0.8*BillAmt;
if ((C>2) II (C<0))
FinalAmt= BillAmt;

```

*( % mark for each statement)*

**NOTE:** award 1 ~ mark if '=' is used instead of '=='



(c) How many times the following while loop get executed?

1

```
int p=5;
int q=36;
while (p<=q)
{
P+=6;
}
```

Ans 6 times

**OR**

6

*(1 marks for correct answer)*

(d) What will be displayed in JTextArea1 after executing the following statement?

1

```
jTextArea1 , setText ("INDIA\nINCREIBLE\tINDIA") ;
```

Ans INDIA

INCREIBLE INDIA

**OR**

Syntax Error

**OR**

Error

**OR**

No output

*(1 mark for correct answer)*

**OR**

*(1 mark for writing the output as INDIA INCREIBLE INDIA )*

**OR**

*(1/2 mark for writing the output in one line as INDIAINCREIBLEINDIA)*

**OR**

*(½ mark for writing the output as INDIA INCREDIBLE\tINDIA)*

**OR**

*(½ mark for writing the output in one line as INDIA \nINCREDIBLE\tINDIA)*

- (e) What will be the values of variables 'm' and 'n' after the execution of the following code? 2

```
int m, n=0;
for (m=1; m<4; m++)
{
    n+=m;
    n--;
}
```

Ans. 5 6

**OR**

M = 5

n = 6

**OR**

5

6

*(2 marks for correct output)*

**OR**

*(1 mark for mentioning only 1 value)*

- (f) Given a string object named Salary having value as "55000" stored in it. Obtain the output of the following. 2

```
JOptionPane.showMessageDialog(null, ""+Salary.length()+
Integer.parseInt (Salary)) ;
```

Ans. 555000

**Note:** 1½ mark to be awarded if length and salary value are stated separately

*( 2 marks for any the answers mentioned above)*

*(1 mark for writing only 5 in output)*

- (g) Anandraj is a programmer at EducoPathshala Enterprises. He created the following GUI in NetBeans. Help him to write code for the following.

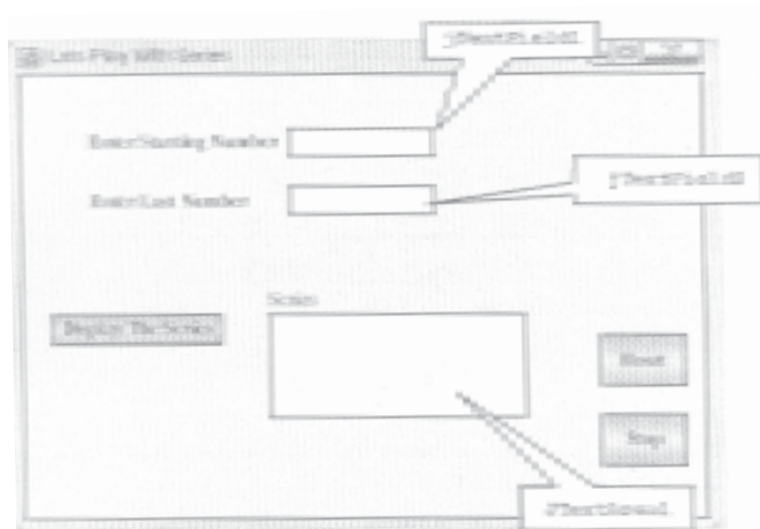

- (i) To display series of odd or even numbers (depending on Starting Number–jTextField1 is even or odd) in the jTextArea on the click of command button [Display The Series].

2

For example:

If the Start Number is 2 and Last Number is 10

Text Area Content will be

2 4 6 8 10

If the Start Number is 5 and Last Number is 10

Text Area Content will be

5 7 9 1 1

```
Ans int s = Integer.parseInt(jTextField1.getText().trim());
int e = Integer.parseInt(jTextField2.getText().trim());
while(s <= e)
```

```

{
jTextArea1.append (" "+s+" ");
s+=2;
}

```

OR

Any other equivalent code

**Note :** Marks not be deducted if Trim( ) method is not used

*(1 mark for correct loop)*

*(1 mark for transferring values from textboxes)*

*(1½ mark if setText ( ) is used in place of append( ) )*

*(1 mark if any other output statement is used)*

- (ii) To clear both the text fields and text area, on clicking [Reset] button 2

```
jTextField1.setText ("") ;
```

```
jTextField2.setText ("") ;
```

```
jTextArea1.setText ("") ;
```

**Note :** Award 1 mark if null is used instead of ""

*(1 mark for clearing anyone textField)*

*(1 mark for clearing textArea)*

- (iii) To terminate the application on the click of [Stop] button. (Assume Suitable names for the various controls on the Form) 1

Ans System.exit (0) ;

OR

```
System.exit ( ) ;
```

*(1 mark for correct statement)*

- 5 (a) What is the purpose of GROUP BY clause in MySQL? How is it different from ORDER BY clause? 2

Ans **GROUP BY** clause groups tuples together based on the specified group attribute(s).

**ORDER BY** clause sorts only the projection by the specified attribute(s).

**OR**

Any other equivalent explanation

**OR**

Purpose & Difference explained through example only

*(1 mark for GROUP BY)*

*(1 mark for ORDER BY)*

(b) Table Hospital has 4 rows and 5 columns. What is the Cardinality and Degree of this table?

1

Ans Cardinality=4

Degree=5

**OR**

4, 5

**OR**

4 5

*(1/2 mark for cardinality)*

*(1/2 mark for degree)*

(c) Consider the Table Supplier given below. Write command in MySQL for (i) to (iv) and output for (v) to (vii)

Table Supplier

Scode	Pname	Supname	Qty	City	Price
101	Coffee	Nestle	200	Kolkata	55.00
102	Biscuit	Hide & Seek	100	Delhi	10.00
103	Jam	Kissan	110	Kolkata	25.00
104	Maggi	Nestle	150	Mumbai	10.00
105	Chocolate	Cadbury	170	Delhi	25.00
106	Sauce	Maggi	56	Mumbai	55.00
107	Cake	Britannia	72	Delhi	10.00

- (i) To display names of the products, whose Pname starts with 'B' in ascending order of Price 1

Ans. `Select Pname from Supplier where Pname like "B%" ORDER BY Price;`

*(1 mark for correct query)*

*(½ mark for writing only LIKE clause)*

*(½ mark for writing only ORDERBY clause)*

*(½ mark for writing only 'SELECT Pname FROM Supplier' )*

- (ii) To display Supplier Code, Product Name and City of the products whose quantity is less than 150 1

Ans. `SELECTS code , Pname, City`

`FROM Supplier`

`WHERE Qty<150;`

*(1 mark for correct query)*

*(½ mark for writing select query without the WHERE Clause)*

- (iii) To count distinct City in the table. 1

Ans. `SELECT COUNT (DISTINCT (City) )`

`FROM Supplier;`

*(1 mark for select query)*

*(½ mark for select query without DISTINCT)*

- (iv) To insert a new row in the table Supplier. 1

`'110', 'Bournvita', 'ABC', 170, 'Delhi', 40.00`

Ans `Insert Into Supplier values ('101', 'Bournvita', 'ABC', '170, 'Delhi' ,40.00);`

Note:

1. If columns are mentioned in the Insert Statement, it should be accepted.
2. No marks should be deducted for omission of quotes

*(1 mark for correct query)*

*(Award ½ mark if TABLE keyword is also mentioned in the query i.e. insert into table shoppe)*

*( Award ½ mark for writing only INSERT keyword)*

(v) Select Pname from Supplier where Pname IN("Bread", "Maggi"); 1

Ans -----

Pnae

-----

Maggi

-----

Note:

1. No marks to be deducted for not mentioning column Title
2. Ignore case of output values

*(1 mark for correct output)*

(vi) Select Count(Distinct(City)) from Supplier; 1

Ans Count(distinct(City) }

-----

3

-----

Note: No marks to be deducted for not mentioning column title

*(1 mark for correct output)*

(vii) Select max(price}from Supplier where City="Kolkata"; 1

Ans MAX (Price)

-----

55

-----

Note: No marks should be deducted for not mentioning column Title

*(1 mark for correct output)*

6. (a) Write MySQL command to create the Table Product including the Constraints.

2

Table: PRODUCT

Name of Column	Type	Size	Constraint
P_Id	Decimal	4	Primary Key
P_Name	Varchar	20	
P_Company	Varchar	20	
Price	Decimal	8	Not Null

Ans. CREATE TABLE Product

(P\_Id DECIMAL(4,0) PRIMARY KEY,

P\_Name VARCHAR(20),

P\_Company VARCHAR(20),

Price DECIMAL(8,0) NOT NULL);

*(1/2 mark for Create Table Product)*

*(1/2 mark for column names with data types)*

*(1/2 mark for each constraint)*

6. (b) In a Database there are two tables:

Table ITEM:

Item_Code	Item_Name	Price
111	Refrigerator	90,000
222	Television	75,000
333	Computer	42,000
444	Washing Machine	27,000

Table BRAND:

Item_Code	Brand_Name
111	LG
222	Sony
333	HCL
444	IFB

Write MySQL queries for the following:



- (i) To display Item\_Code, Item\_Name and corresponding Brand\_Name of those Items, whose Price is between 20000 and 40000 ( both values inclusive). 2

Ans. SELECT A.Item\_Code , Item\_Name, Brand Name

FROM ITEM A, BRAND B

WHERE A.Item Code= B.Item Code and Price BETWEEN  
20000 AND 40000;

OR

SELECT A.Item\_Code , Item\_Name, Brand\_Name FROM ITEM A,  
BRAND B

WHERE A.Item Code= B.Item Code AND Price >= 20000 AND  
Price <= 40000;

Note: Use of alias names for tables optional

*(2 marks for correct query)*

*(1 mark for mentioning only the range condition)*

*(1 mark for mentioning only equi join condition)*

*(1 mark if "AND" is mentioned in the FROM clause or SELECT clause)*

- (ii) To display Item\_code, Price and Brand\_Name of the item which has Item\_Name as "Computer" .

Ans. SELECT A.Item\_Code , Item\_Name, Brand\_Name

FROM ITEM A, BRAND B

WHERE A.Item\_Code = B.Item\_Code AND Item\_Name="Computer";

*(2 marks for correct query)*

*(1 mark for mentioning only equi join condition)*

*(1 mark for mentioning only the condition Item\_Name = 'Computer')*

*(1 mark if "AND" is mentioned in the FROM clause or SELECT clause)*

- (iii) To increase the price of all the items by 10% 2

Ans. UPDATE Item SET Price = Price + Price\*0.10;

OR

```
UPDATE Item SET Price = Price + Price*.10;
```

OR

```
UPDATE Item SET Price = Price + Price*10/100;
```

OR

```
SELECT Price*1.1 FROM Item;
```

*(2 marks for correct UPDATE/SELECT query)*

*(1 % marks if keyword TABLE is mentioned in the UPDATE statement)*

*(1 mark if only UPDA TE keyword is used)*

*(Award 1 mark if there is an error in UPDATE expression)*

(c) Given below is a Table Patient.

Name	P No	Date_Admn	Doc No
VimlaJain	P0001	2011-10-11	0201
IshitaKohli	P0012	2011-10-11	0506
Vijay Verma	P1002	2011-10-17	0201
Vijay Verma	P1567	2011-11-22	0233

(i) Identify Primary key in the table given above.

1

Ans. P\_No

*(1 mark for correct query)*

*(1 mark if Patient Number is given as the answer)*

(ii) Write MySql query to add a column Department with data type varchar and size 30 in the table Patient.

1

Ans. ALTER Table Patient ADD Department VARCHAR(30) ;

*(1 mark for correct query)*

*(1/2 mark for writing AL TER TABLE only)*

*(1/2 mark if size is omitted)*

*(1/2 mark if type is CHAR)*

7 (a) What social impact does e-Governance have on society? 1

Ans e-Governance ensures:

Transparency of governance

**OR**

Efficiency of governance

**OR**

Any other equivalent points bringing out social impact of e-governance

*(1 mark for writing any 1 impact)*

(b) Write two important features of e-Business. Give two most commonly used e-Business sites. 2

Ans **Features:**

(i) Helps reach customers effectively and speedily

(ii) Helps customers to order on-line

(iii) Helps in getting feedback from customers ..

(iv) Helps inter-business transactions

**Commonly used e-Business sites**

e-Bay.com

Amazon.com

**OR**

Any two features of e-Business and e-Business websites

*(1/2 mark for each feature)*

*(1/2 mark for each website)*

(c) Mr. Anurag Das working as Manager in Vivian Enterprises wants to create a form in NetBeans to take various inputs from user. Choose appropriate controls from Label, TextBox, Radio Button, Check Box, ListBox, Combo Box and Command Button and write them in the third column: 2

S.No.	Control used to	Control
1.	Enter Name, Address and Salary	
2.	Select Gender (Male/Female)	
3.	Select Department from available List	
4.	Choose Hobby of Employee (Singing/Dancing/Skating/Swimming)	

Ans

S.No.	Control used to	Control
1.	Enter Name, Address and Salary	TextBox
2.	Select Gender (Male/Female)	Radio Button
3.	Select Department from available List	ListboxjComboBox
4.	Choose Hobby of Employee (Singing/Dancing/Skating/Swimming)	ComboBoxj CheckboxjRadioButton/ ListBox

*(½ mark for each answer)*

### QUESTION PAPER CODE 90

#### EXPECTED ANSWERS

- 1 (a) Raj Kamal International School is planning to connect all computers, each spread over distance within 45 meters. Suggest an economical cable type having high-speed data transfer, which can be used to connect these computers.

1

Ans UTP (Unshielded Twisted Pair)

**OR**

Coaxial Cable

**OR**

STP (Shielded Pair Cable)

*(1 mark for correct answer)*

(b) Name two Indian Scripts included in UNICODE. 1

Ans. Devanagari, Telugu

**OR**

Any 2 Indian Scripts

*(1/2 mark for each correct answer)*

(c) Write examples of one Proprietary and one Open Source Software. 1

Ans. **Proprietary:** MS OFFICE

**Open Source:** Open OFFICE

OR

Any other correct answer for each type of software

*(1/2 mark for each correct answer)*

(d) Name any two most popularly used internet browsers. 1

Ans. Google Chrome

Mozilla Firefox

**OR**

Any 2 correct browser names

*(1/2 mark for each correct answer)*

(e) Ms. Rani Sen, General Manager of Global Nations Corporate recently discovered that the communication between her company's accounts office and HR office is extremely slow and signals drop quite frequently. These offices are 125 metres away from each other and connected by an Ethernet cable. 1

(i) Suggest her a device, which can be installed in between the offices for smooth communication.

Ans. Repeater

**OR**

Switch

Note: Router also to be accepted

*(1 mark for answer)*

(iii) What type of network is formed by having this kind of connectivity out of LAN, MAN and WAN?

Ans. LAN

**OR**

Local Area Network

*(1 mark for answer)*

(f) Give an advantage of using Star topology over Bus topology. Show a network layout of Star topology to connect 5 computers.

2

Ans.

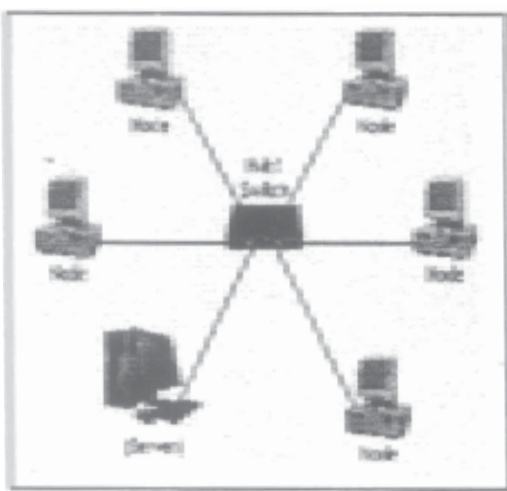

**Advantages**

More efficient

**OR**

Faults can be diagnosed easily

**OR**

Any other advantage

*(1 mark for advantage)*

*(1 mark for any star topology layout)*

(g) Give suitable example of URL and Domain name

2

Ans. **URL** : <http://www.cbse.nic.in/welcome.htm>

**Domain name:** www.cbse.nic.in

**OR**

Any other example for URL and Domain name

Note:

1. Answers where domain name is not a part of the URL also to be accepted
2. Absence of http:// may be ignored

*(1 mark for URL)*

*(1 mark for Domain Name)*

2. (a) While making a Form in Netbeans, Mr. Halihar Jha wants to display a list of countries to allow the users to select their own country. Suggest him to choose most appropriate control out of ListBox and ComboBox. 1

Ans. ListBox

**OR**

ComboBox

*(1 mark for any correct answer)*

- (b) What is the purpose of break keyword while using Switch Case Statement? Illustrate with the help of an example. 1

Ans Break stops the flow of logic within the switch statement and the statement immediately following the switch is executed.

**OR**

Break statement prevents "fall through" in the switch statement

*Example:*

```
switch(n)
{
case 10:
System.out.println("Ten");
break;
case 20:
```

```
System.out.println("Twenty") ;  
break;  
default:  
System.out.println("Not Ten or Twenty") ;  
}
```

**OR**

Any other example of switch statement

*(1/2 mark for purpose of break)*

*(1/2 mark for correct switch statement example)*

- (c) Write the name HTML tag used to include numbered list in a HTML Web Page. 1

Ans. <OL>

**OR**

Mentioning ORDERED LIST Tag

*(1 mark for correct answer)*

- (d) Write HTML code for the following: 1

To provide hyperlink to a website <http://www.cbse.nic.in>

Ans. <A HREF="http://www.cbse.nic.in"> CLICK HERE TO GO CBSE SITE </A>

*(1 mark for correct HTML TAG)*

**OR**

*(1 mark if any part of Q2 has been attempted correctly)*

**OR**

*(1 mark for attempting the question)*

- (e) What will be the content of the JTextArea1 after executing the following code (Assuming that the JTextArea1 had no content before executing this code)? 2

```
for (int C=1; C=4; C++)  
{
```



```

jTextAreal.setText (
    jTextAreal.getText ( ) + " " +
    Integer.toString (C*C) ) ;
}

```

Ans. Refer Note

*Note:*

*(2 marks to be awarded for anyone of the following answers:*

1. *Syntax Error*
2. *Program will not compile*
3. *No output*

**OR**

*(2 marks to be awarded if operator is changed and any output is written)*

(f) Which of the following units measures the speed with which data can be transmitted from one node to another node of a network? Also give the expansion of the suggested unit. 2

- (i) KMph
- (ii) KMpl
- (iii) Mbps

Ans **Mega bits per second**

(Note :Mega bytes per second may also be accepted)

*(1 mark for identifying unit of measure)*

*(1 mark for expansion)*

(g) Write Java code that takes value for a number (n) in jTextField1 and cube (n\*n\*n) of it to be displayed in jTextField2. 2

Ans. `double n=Double.parseDouble(jTextField1.getText ( ) ) ;`  
`double m=n*n*n;`  
`jTextField2.setText (" "+m) ;`

**OR**

Any other equivalent code

Note: n can be taken as int or float

*(1 mark for getting the value from jTextField1)*

*(1/2 mark for calculating cube)*

*(1/2 mark for displaying in jTextField2)*

**Note: - Do not deduct marks for error in formula**

3 (a) Write MySql command to open an existing database. 1

Ans USE (Any database name)

OR

USE

*(1 mark for the answer)*

(b) Ms. Mirana wants to remove the entire content of a table "BACKUP" along-with its structure to release the storage space. What MySql statement should she use? 1

Ans DROP TABLE BACKUP

**OR**

DROP TABLE

*(1 mark for the answer)*

*(1/2 mark for mentioning only DROP)*

(c) Give one difference between ROLLBACK and COMMIT commands used in MySql. 1

Ans **ROLLBACK** aborts transaction and does not save any of the changes made to the database during the transaction.

**COMMIT** statement saves all changes made during the transaction to the database.

**OR**

Any other equivalent answer/example

*(1/2 mark for ROLLBACK)*

*(1/2 mark for COMMIT)*

- (d) A table STUDENTS has 4 rows and 2 columns and another table TEACHER has 3 rows and 4 columns. How many rows and columns will be there if we obtain the Cartesian product of these two tables?

1

Ans **12 rows, 6 columns**

**OR**

**12, 6**

**OR**

**12 6**

*(1/2 mark for rows)*

*(1/2 mark for columns)*

- (e) Mr. Sang hi created two tables with CITY as Primary Key in Table1 and Foreign Key in Table2. While inserting a row in Table2, Mr. Sanghi is not able to enter a value in the column CITY. What could be the possible reason for it?

2

Ans Referential integrity enforcement ensures that value must exist in referred table for successful insertion in the dependent table.

**OR**

Mentioning Primary key - Foreign key relationship

**OR**

Any other answer that illustrates the Primary key - Foreign key relationship concept

*(2 marks for correct answer)*

- (f) Item code consisting of 5 digits is stored in an integer type variable intItemCode. Mr. Srikant wants to store this Item code in a String type variable called strItemCode.

2

Write appropriate Java statement(s) to help her in performing the same.,

Ans. `String strItemCode = Integer.toString(intItemCode);`

**OR**

Any other equivalent statement

NOTE: String object need not be declared

*(2 marks for correct answer)*

*(1 mark if the variable names has been changed)*

(g) Mr. Janak is using a table with following columns:

2

Name, Class, Course\_id, Course\_name

He needs to display names of students, who have not been assigned any stream or have been assigned Course\_name that ends with 'economics '

He wrote the following command, which did not give hte desired result.

```
SELECT Name, Class FROM Students
```

```
WHERE Course name=NULL OR Course name= "%economics";
```

Help Mr. Janak to run the query by removing the error and write the correct query.

Ans SELECT Name, Class

```
FROM Students
```

```
WHERE Course_name IS NULL
```

**OR**

```
SELECT Name, Class
```

```
FROM Students
```

```
WHERE Course_name LIKE "%economics";
```

*(2 marks for correct query)*

**OR**

*(1 mark for IS NULL)*

*(1 mark for LIKE)*

**OR**

*(Award 1½ mark if only errors are identified)*

4. (a) What message will be displayed after the executing of the following code? 2

```
int Age=64, Relaxation=4;
int ModiAge=Age-Relaxation;
if (ModiAge<60)
    JOptionPane.showMessageDialog (Null, "NOT Eligible")
else
    JOptionPane.showMessageDialog(Null. "Eligible")
```

Ans. Eligible

**OR**

Syntax Error

**OR**

Error

**OR**

No output

*(2 marks for any answer mentioned above)*

- (b) Rewrite the following program code using a If statement: 2

```
int C=jComboBox1.getSelectedIndex ();
switch (C)
{
    case 0 : Amount=Bill;break;
    case 1 : Amount=0.9*Bill;break;
    case 2 : Amount=0.8*Bill;break;
    default: Amount=Bill;
}
```

Ans. if(C= =0) Amount=Bill;  
else if (C= =1) Amount=0.9\*Bill;

```
else if (C==2) Amount=0.8*Bill;
```

```
else Amount=Bill;
```

**OR**

```
if (C==0) Amount=Bill;
```

```
if (C==1) Amount=0.9*Bill;
```

```
if (C==2) Amount=0.8*Bill;
```

```
if ((C>2) || (C<0)) Amount=Bill;
```

*(1/2 mark for each statement)*

**NOTE: award 1 1/2 mark if. '=' is used instead of '=='**

- (c) How many times does the following while loop get executed? 1

```
int K=5i
int L=36i
while (K<=L)
{
    K+=6 ;
}
```

Ans. **6 times**

**OR**

**6**

*(1 marks for correct answer)*

- (d) What will be displayed in JTextArea1 after executing the following statement? 1

```
jTextArea1, setText ("GREAT\nCOUNTRY\tINDIA");
```

Ans. GREAT

COUNTRYINDIA

**OR**

Syntax Error

**OR**

Error

**OR**

No output

*(1 mark for correct answer)*

**OR**

*(1 mark for writing the output as GREAT COUNTRY INDIA )*

**OR**

*(1/2 mark for writing the output in one line as GREATCOUNTRYINDIA)*

**OR**

*(1/2 mark for writing the output as GREAT COUNTRY\tINDIA)*

**OR**

*(1/2 mark for writing the output in one line as GREAT\nCOUNTRY\tINDIA)*

- (e) What will be the values of variables 'm' and 'n' after the executing of the following code?

2

```
Int P, Q=Q
For (P=1 ; P<=4 ; P++)
{
Q+=P
Q-- ;
}
```

Ans. **5 6**

**OR**

**m = 5**

**n = 6**

**OR**

**P=5**

**Q=6**

**OR**

**5**

**6**

**OR**

Variables not found

**OR**

No output/values

**OR**

Error in Question

*(2 marks for correct output)*

**OR**

*(1 mark for mentioning only 1 value)*

**OR**

*(2 marks for attempting the question)*

- (f) Given a string object named Pay having value as "68000" stored in it. Obtain the output of the following: 2

```
JOptionPane.showMessageDialog (null,  
" " +Salary.length ( ) +Integer.parseInt (Salary));  
568000
```

**OR**

Variables not found

**OR**

No output

Note: award 1½ mark if length and Pay value are stated separately Le 5 && 68000

*(2 marks for any the answers mentioned above)*

*(1 mark for writing only 5 in output)*



- (g) Janav Raj is a programmer at Path Educo Enterprises. He created the following GUI in NetBeans. Help him to write code for the following:

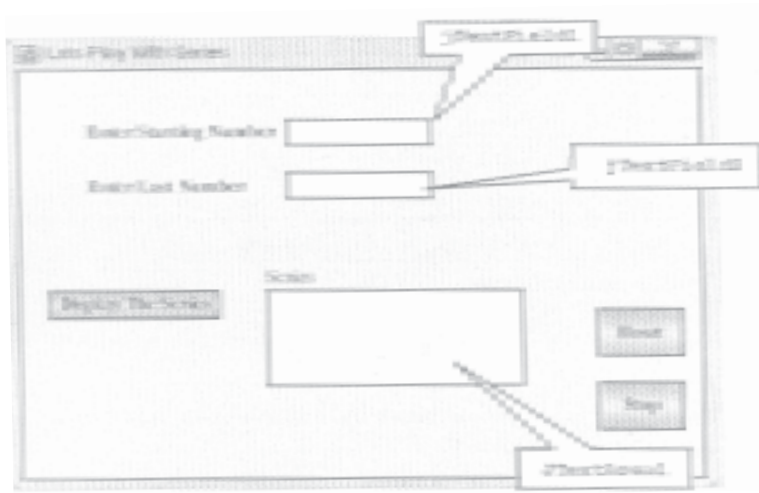

- (i) To display series of odd or even numbers (depending on Starting Number - jTextField1 is even or odd) in the JTextArea on the click of command button [Display The Series].

2

For example:

If the Start Number is 5 and Last Number is 11

Text Area Content will be

57911

If the Start Number is 2 and Last Number is 10

Text Area Content will be

246810

```
Ans. int s = Integer.parseInt(jTextField1.getText().trim());
int e = Integer.parseInt(jTextField2.getText().trim());
while(s <= e)
{
jTextArea1.append(" "+s+" ");
s+=2;
}
```

**OR**

Any other equivalent code

**Note:** Marks not be deducted if Trim() method is not used

*(1 mark for correct loop)*

*(1 mark for transferring values from textboxes)*

*(1½ mark if setText ( ) is used in place of append() )*

*(1 mark if any other output statement is used)*

- (ii) To clear both the text fields and text area, on clicking [Reset] button. 2

```
jTextField1.setText ( "" ) ;
```

```
jTextField2.setText ( "" ) ;
```

```
jTextArea1.setText ( "" ) ;
```

**Note:** Award 1 Y2 mark if null is used instead of " "

*(1 mark for clearing anyone textField)*

*(1 mark for clearing textArea)*

- (iii) To terminate the application on the click of [Stop] button. (Assume Suitable names for the 11 various controls on the Form) 1

```
System. exit (0) ;
```

**OR**

```
System. exit ( ) ;
```

*(1 mark for correct statement)*

5. (a) What is the purpose of ORDER BY clause in MySql? How is it different from GROUP BY clause? 2

Ans **ORDER BY** clause sorts only the projection by the specified attribute(s).

**GROUP BY** clause groups tuples together based on the specified group attribute(s).

**OR**

Any other equivalent explanation

**OR**

Purpose & Difference explained through example only

*(1 mark for ORDER BY)*

*(1 mark for GROUP BY)*

- (b) Table SCHOOL has 4 rows and 5 columns. What is the Cardinality and Degree of this table?

**Cardinality:** 4

**Degree:** 5

**OR**

4, 5

**OR**

4 5

*(½ mark for cardinality)*

*(½ mark for degree)*

- (c) Consider the Table SHOPPE given below. Write command in MySQL for (i) to (iv) and output for (v) to (vii).

Table **SHOPPE:**

Code	Item	Company	Qty	City	Price
102	Biscuit	Hide & Seek	100	Delhi	10.00
103	Jam	Kissan	110	Kolkata	25.00
101	Coffee	Nestle	200	Kolkata	55.00
106	Sauce	Maggi	56	Mumbai	55.00
107	Cake	Britannia	72	Delhi	10.00
104	Maggi	Nestle	150	Mumbai	10.00
105	Chocolate	Cadbury	170	Dehli	25.00

- (i) To display names of the items whose name starts with 'C' in ascending order of Price.

Ans SELECT ITEM FROM SHOPPE WHERE ITEM LIKE ' C% '  
ORDER BY PRICE ASC;

NOTE:

1. Writing ASC keyword is optional
2. Accept order by without space also i. e. ORDERBY

*(1 mark for correct query)*

*(1/2 mark for writing only LIKE clause)*

*(1/2 mark for writing only ORDER BY clause)*

*(1/2 mark for writing only 'SELECT ITEM FROM SHOPPE')*

- (ii) To display Code, Item name and City of the products whose quantity is less than 100. 1

Ans SELECT Code, Item, City

FROM Shoppe

WHERE Qty < 100;

*(1 mark for correct query)*

*(1/2 mark for writing select query without the WHERE Clause)*

- (iii) To count distinct Company from the table. 1

Ans SELECT COUNT(DISTINCT Company)

FROM Shoppe;

*(1 mark for select query)*

*(1/2 mark for select query without DISTINCT)*

- (iv) To insert a new row in the table Shoppe 1

'110', 'Pizza', 'Papa Jones', 120, "Kolkata", 50.0

Ans INSERT INTO SHOPPE VALUES ( '110', 'Pizza', 'Papa Jones',  
120, 'Kolkata', 50.0);

**Note:**

1. If columns are mentioned in the Insert Statement, it should be accepted.

2. No marks should be deducted for omission of quotes
3. No marks should be deducted for writing VALUE keyword instead of VALUES

*(1 mark for correct query)*

*(Award mark if TABLE keyword is also mentioned in the query i.e. insert into table shoppe)*

*(Award mark for writing only INSERT keyword)*

(v) Select Item from Shoppe where Item IN ("Jam", "Coffee");

1

Ans -----

Item

-----

Jam Coffee

-----

**Note :**

1. If the values are written in one row and in any other order do not deduct marks
2. No marks to be deducted for not mentioning column Title
3. Ignore case of output values

*(1 mark for correct output)*

*(1/2 mark for each correct value)*

(vi) Select Count (distinct (City)) from Shoppe;

1

Ans. Count(distinct(City))

-----

3

-----

Note: No marks to be deducted for not mentioning column Title

*(1 mark for correct output)*

(vii) Select MIN (Qty) from Shoppe where City="Mumbai";

1

MIN(Qty)

-----

56

-----

**Note:** No marks should be deducted for not mentioning column Title

*(1 mark for correct output)*

6. (a) Write MySql command to create the Table STOCK including its Constraints.

**Table STOCK:**

Name of Column	Type	Size	Constraint
Id	Decimal	4	Primary Key
Name	Varchar	20	
Company	Varchar	20	
Price	Decimal	8	Not Null

Ans CREATE TABLE stock

```
(  
    Id DECIMAL (4) PRIMARY KEY,  
    Name VARCHAR (20) ,  
    Company VARCHAR (20) ,  
    Price DECIMAL (8) NOT NULL  
);
```

**NOTE :** Ignore absence of ',' after each column detail

*(1/2 mark for Create Table Stock)*

*(1/2 mark for column names with data types)*

*(1/2 mark for each constraint)*

(b) In a Database there are two tables:

2

**Table ITEM:**

<b>ICode</b>	<b>Iname</b>	<b>Price</b>
101	Television	75000
202	Computer	42000
303	Refrigerator	90000
404	Washing Machine	27000

**Table BRAND:**

<b>ICode</b>	<b>Brand</b>
101	Sony
202	HP
303	LG
404	IFB

(i) To display ICode, IName and corresponding Brand of those Items, whose Price is between 20000 and 45000 (both values inclusive).

2

Ans. `SELECT Item. ICode, IName, Brand`

`From Item, Brand`

`WHERE Item.ICode=Brand.ICode AND Price BETWEEN 20000 AND 45000;`

**OR**

`SELECT Item. ICode, IName, Brand`

`From Item, Brand`

`WHERE Item.Icode=Brand.lcode AND Price>=20000 AND price<= 45000;`

**Note:** Use of alias names for tables optional

*(2 marks for correct query)*

*(1 mark for mentioning only the range condition)*

*(1 mark for mentioning only equi join condition)*

*(1 mark if "AND" is mentioned in the FROM clause or SELECT clause)*

(ii) To display ICode, Price and BName, of the item which has IName as "Television" 2

Ans SELECT IT EM. I code, Price, Brand

FROM Item, Brand

WHERE ITEM.Icode=Brand.Icode AND Iname= 'Television' ;

**Note:**

1. Accept any other column name instead of BName
2. Award 2 marks for 'Error in query'/'Column not found' is mentioned

*(2 marks for correct query)*

*(1 mark for mentioning only equi join condition)*

*(1 mark for mentioning only the condition IName = 'Television')*

*(1 mark if "AND" is mentioned in the FROM clause or SELECT clause)*

(iii) To increase the price of all Item by 15% 2

Ans UPDATE Item SET Price =Price\*1.15;

OR

UPDATE Item SET Price = Price + Price\*.15;

OR

UPDATE Item SET Price = Price + Price\*15/100;

OR

SELECT Price\*1.15 FROM Item;

*(2 marks for correct UPDATE/SELECT query)*

*(1 marks if keyword TABLE is mentioned in the UPDATE statement)*

*(1 mark if only UPDATE keyword is used)*

*(Award 1 mark if there is an error in UPDATE expression)*

(c) Given below is a Table Patient.

Name	P No	Date Admn	Doc No
VimlaJain	POO01	2011-10-11	0201
Ishita Kohli	P0012	2011-10-11	0506
Vijay Verma	P1002	2011-10-17	0201
Vijay Verma	P1567	2011-11-22	0233



(i) Identify Primary key in the table given above.

1

Ans P\_NO

*(1 mark for correct query)*

*(1 mark if Patient Number is given as the answer)*

(ii) Write MySql query to add a column Department with data type varchar and size 30 in the table Patient.

Ans ALTER TABLE Patient ADD Department Varchar (30) ;

**Note:** Column Keyword in ALTER TABLE is optional

*(1 mark for correct query)*

*(1/2 mark for writing ALTER TABLE only)*

*(1/2 mark if size is omitted)*

*(1/2 mark if type is CHAR)*

7. (a) What social impact does e-Governance have on society?

1

Ans **e-Governance ensures:**

Transparency of governance

**OR**

Efficiency of governance

**OR**

Any other equivalent points bringing out social impact of e-governance

*(1 mark for writing any 1 impact)*

(b) Write two important features of e-Business. Give two most commonly used e-Business sites.

2

Ans **Features of e-Business**

(i) Helps reach customers effectively and speedily

(ii) Helps customers to order on-line

(iii) Helps in getting feedback from customers

(iv) Helps inter-business transactions

**Commonly used e-Business sites**

e-Bay.com

Amazon.com

**OR**

Any two features of e-Business and any two e-Business websites

*(1/2 mark each for any two features)*

*(1/2 mark each for any two websites)*

- (c) Mr. Anurag Das working as Manager in Vivian Enterprises wants to create a form in NetBeans to take various inputs from user. Choose appropriate controls from Label, TextBox, Radio Button, CheckBox, ListBox, ComboBox, and Command Button and write them in the third column:

2

S.No.	Control used to	Control
1.	Enter Name, Address and Salary	
2.	Select Gender (Male/Female)	
3.	Select Department from available list	
4.	Choose Hobby of Employee (Singing/Dancing/Skating/Swimming)	

Ans

S.No.	Control used to	Control
1.	Enter Name, Address and Salary	TextBox
2.	Select Gender (Male/Female)	Radio Button
3.	Select Department from available list	ListBox/ComboBox
4.	Choose Hobby of Employee (Singing/Dancing/Skating/Swimming)	ComboBox/ Checkbox/RadioButton/ ListBox

*(1/2 mark for each answer)*

# COMPUTER SCIENCE

*Time allowed : 3 hours*

*Maximum Marks : 70*

***Instructions:***

- (i) *All questions are compulsory.*
- (ii) *Programming Language: C++*

## QUESTION PAPER CODE 91/1

- 1 (a) Difference between the formal parameters and actual parameters. Also, give a suitable C++ code to illustrate both. 2
- (b) Which C++ header file(s) are essentially required to be included to run/execute the following C++ source code (Note: Do not include any header file, which is/are not required) : 1
- ```
{  
char STRING []="SomeThing";  
cout<<"Balance Characters:"<<160-strlen (STRING) <<endl;  
}
```
- (c) Rewrite the following program after removing the syntactical errors (if any). Underline each correction. 2
- ```
#include<iostream.h>  
class BOOK  
{  
    long BId,Qty;  
Public:  
    void Purchase() {cin>>BId>>Qty;}  
    void Sale  
    {
```

```

        cout<<setw(5)<<BId<<"Old:"<<Qty<<endl;
        cout<<"New: " <<--Qty<<endl;
    }
};
void main ()
{
    BOOK B;
    B.Purchase() ;
    Sale ();
    B. Sale ()
}

```

(d) Find the output of the following program:

3

```

#include<iostream.h>
class TRAIN
{
    int Tno, TripNo, PersonCount;
public:
    TRAIN(int Tmno=1) {Tno=Tmno;TripNo=0;PersonCount=0;}
    void Trip(int TC=100) {TripNo++;PersonCount+=TC;}
    void Show() {cout<<Tno<<": "<<TripNo<<": "<<PersonCount<<endl;}
};
void main ( )
{
    TRAIN T(10) ,N;
    N. Trip ();
    T . Show ();
}

```

```

    T.Trip(70);
    N.Trip(40);
    N. Show ();
    T . Show ();
}

```

- (e) Find the output of the following program:

2

```

#include<iostream.h>
#include<ctype.h>
typedef char Txt80 [80];
void main ( )
{
    Char *PTexti
    Txt80 Txt="Ur2GReAt ";
    int N=6;
    PText=Txt;
    while (N>=3)
    {
        Txt [N]=(isupper (Txt [N])?tolower (Txt [N] :toupper (Txt [N] ));
        cout<<PText<<endl;
        N--;
        PText++;
    }
}

```

- (f) Observe the following program and find out, which output(s) out of (i) to (iv) will not expected from the program? What will be the minimum and the maximum value assigned to the variable Chance?

2

```

#include <iostream.h>
#include <stdlib.h>

```

```

void main ( )
{
    randomize ( )
    int Game []={10,16}, P;
    int Turn=random(2)+5;
    for(int T=0; T<=2; T++)
    {
        P=random (2) ;
        Cout<<Game [P] + Turn<<"*";
    }
}

```

(i) 15 # 22 #

(ii) 22 # 16 #

(iii) 16 # 21 #

(iv) 21 # 22 #

2. (a) What is the difference between the members in private visibility mode and the members in public visibility mode inside a class? Also, give a suitable C++ code to illustrate both. 2

- (b) Answer the questions(i) and (ii) after going through the following class: 2

```

class Tour
{
    int LocationCode;char Location[20];float Charges;
public:
    Tour() //Function 1
    {
        LocationCode=1; strcpy(Location, "PURI"); Charges=1200;
    }
}

```

```

    }
    void TourPlain(float C)                //Function 2
    {
        cout<<PlaceCode<<": "<<Place<<": "<<Charges<<endl;
        Charge+=100;
    }
    Tour(int LC, char L[], float C) {      //Function 3
        LocationCode=LC; strcpy (Location,L); Charges=C;
    }                                       //Function 4
    ~Tour ( )
    {
        cout<<"Tour Plan Cancelled"<<endl;
    }
} ;

```

- (i) In Object Oriented Programming, what are Function 1 and Function 3 combined together referred as?
- (ii) In Object Oriented Programming, which concept is illustrated by Function 4? When is this function called/invoked?
- (c) Define a class SUPPLY in C++ with following description: 4

Private Members

- Code of type int
- Food Name of type string
- Sticker of type string
- Food Type of type string
- A member function Get Type ( ) to assign the following values for

Food Type as per the given Sticker:

Sticker	Food Type
GREEN	Vegetarian
YELLOW	Contains Egg
RED	NON-Vegetarian

Public Members

- A function FoodIn () to allow user to enter values for Code, FoodName, Sticker and call function Get Type () to assign respective FoodType.
- A function FoodOut () to allow user to view the content of all the data members.

(d) Answer the questions (i) to (iv) based on the following:

4

```
class ORGANIZATION
(
    char Address [20] ;
    double Budge, Income;
protected:
    void Computet ();
public:
    ORGANIZATION ();
    void Get ();
    void Show ();
} ;

class WORKAREA: Public ORGANIZATION
{
    char Address [20] ;
    int Staff;
```



```

protected:
    double Pay;
    void Calculate();

public:
    WORKAREA ();
    void Enter();
    void Display();
};

class SHOWROOM: Private ORGANIZATION
{
    char Address [20];
    void Enter();
    void Show();
};

```

- (i) Name the type of inheritance illustrated in the above C++ code.
  - (ii) Write the names of all the data members, which are accessible from member functions of class SHOWROOM
  - (iii) Write the names of all the member functions, which are accessible from objects belonging to class WORKAREA.
  - (iv) Write the name of all the members, which are accessible from objects of Class SHOWROOM.
3. (a) Write a function SWAP2CHANGE (int p [], int N) in C++ to modify the content of the array in such a way that the elements, which are multiples of 10 swap with the value present in the very next position in the array.

3

For Example:

If the content of array P IS

91, 50, 54, 22, 30, 54

The content of array P should become

91, 54, 50, 22, 54, 30

- (b) An array 5[10][30] is stored in the memory along the column with each of its element occupying 2 bytes. Find out the memory location of 5[5][10], if element 5[2][15] is stored at the location 8200. 3
- (c) Write a function in C++ to perform Insert operation on a dynamic Queue containing DVD'S information (represented with the help of an array of structure DVD). 4
- ```

struct DVD
{
    long No;          //DVD Number
    char Title[20];  //DVD Title DVD *Link;
} ;

```
- (d) Write a function SKIPEACH (int H[] [3], int C, int R) in C++ to display all alternate elements from two - dimensional array H (starting from H [0] [0]). 2
- For example:
- If the array is containing:
- |    |    |    |
|----|----|----|
| 12 | 45 | 67 |
| 33 | 90 | 76 |
| 21 | 43 | 59 |
- The output will be
- |    |    |    |    |
|----|----|----|----|
| 12 | 67 | 90 | 59 |
|----|----|----|----|
- (e) Evaluate the following POSTFIX notation. Show status of Stack after every step of evaluation (i.e after each operation.) 2
- False, NOT, True, AND, True, False, OR, AND
- 4 (a) Observe the program segment given below carefully and the questions that follow: 1
- ```

class Inventory
{
    int Ano, Qty; char Article [20] ;
public:
    void Input () {cin>>Ano; gets (Article) :cin>>Qty;}
}

```

```

void Issue(int Q) {Qty+=Q;}
void procure(int Q) {Qty-=Q;}
int GetAno() {return Ano;}
};
void ProcureArticle (int TAno, int TQty)
{
    fstream File;
    File.open ("STOCK, DAT", ios::binary|ios::in|ios::out);
    Inventory I;
    int Found =0;
    while (Found ==0 && File.read<char*>&I, sizeof(I))
    {
        if (TAno == S. GetAno())
        {
            I. Procure (TQty) ;
            _____ // Statement 1
            _____ // Statement 2
            Found ++;
        }
    }
    if (Found == 1)
        cout<<"Procurement Updated"<<endl;
    else
        cout<<"Wrong Article No"<<endl.;
    File.close() :
}

```

- (i) Write statement 1 to position the file pointer to the appropriate place, so that the data updation is done for the required Article.

- (ii) Write statement 2 to perform the write operation so that the updation is done in the binary file.
- (b) Write a function in C++ to read the content of a text file "PLACES.TXT" and display all those lines on screen, which are either starting with 'P' or starting with 'S'. 2
- (c) Write a function in C++ to search for the details (Number and Calls) of those Mobile phones, which have more than 1000 calls from a binary file "mobile.dat". Assuming that this binary file contains records/objects of class Mobile, which is defined below: 3

```
class Mobile
{
    char Number [10]; int Calls;
public:
    void Enter() {gets (Number); cin>> Calls;}
    void Billing() {cout<< Number<<"#"<<Calls<<endl;}
    int GetCalls() {return Calls;}
} ;
```

5. (a) Give a suitable example of a table with sample data and illustrate Primary and Candidate Keys in it. 2

**Consider the following tables CABHUB and CUSTOMER and answer (b) and (c) parts of this question:**

Table: CABHUB

Vcode	VehicleName	Make	Color	Capacity	Charges
100	Innova	Toyota	WHITE	7	15
102	SX4	Suzuki	BLUE	4	14
104	C Class	Mercedes	RED	4	35
105	A-Star	Suzuki	WHITE	3	14
108	Indigo	Tata	SILVER	3	12

Table : CUSTOMER

CCode	CName	Vcode
1	Hemant Sahu	101
2	Raj Lal	108
3	Feroza Shah	105
4	Ketan Dhal	104

- (b) Write SQL commands for the following statements: 4
- (i) To display the names of all the white colored vehicles.
  - (ii) To display name of vehicle, make and capacity of vehicles in ascending order of their sitting capacity.
  - (iii) To display the highest charges at which a vehicle can be hired from CABHUB.
  - (iv) To display the customer name and the corresponding name of the vehicle hired by them.

- (c) Give the output of the following SQL queries: 2
- (i) `SELECT COUNT (DISTINCT Make) from CABHUB;`
  - (ii) `SELECT MAX (Charges), MIN (Charges) FROM CABHUB;`
  - (iii) `SELECT count (*), Make FROM CABHUB;`
  - (iv) `SELECT Vehicle FROM CABHUB WHERE Capacity = 4;`

6. (a) Verify the following using truth table: 2
- (i)  $X + 0 = X$
  - (ii)  $X + X' = 1$

- (b) Write the equivalent Boolean Expression for the following Logic Circuit: 2

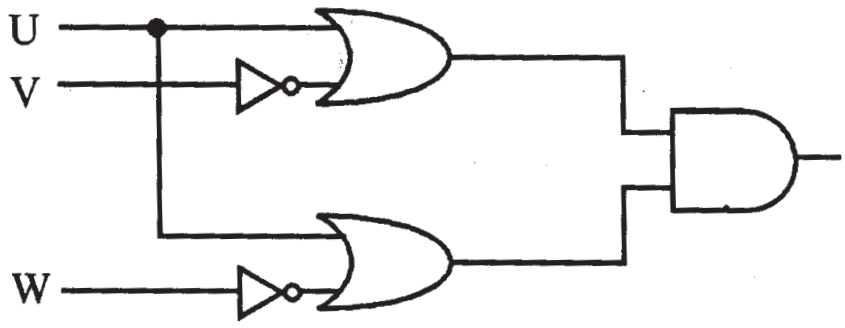

- (c) Write the POS form of a Boolean function G, which is represented in a truth table as follows: 1

A	B	C	G
0	0	0	0
0	0	1	1
0	1	0	1
0	1	1	0
1	0	0	0
1	0	1	0
1	1	0	1
1	1	1	1

- (d) Reduce the following Boolean Expression using K-Map: 3  
 $F(P, Q, R, S) = \sum (1, 2, 3, 4, 5, 6, 7, 8, 10)$
7. (a) What out of the following, you will use to have an audio-visual chat with an expert sitting in a faraway place to fix-up a technical issue? 1
- (i) Email
  - (ii) VoIP
  - (iii) FTP
- (b) Name one Client side scripting language and one Serverside scripting language. 1
- (c) Which out of the following does not come under Cyber Crime? 1
- (i) Stealing a mouse from someone's computer.
  - (ii) Operating someone's Internet Banking account, without his knowledge.
  - (iii) Entering in someone's computer remotely and copying data, without seeking his permission.
- (d) Write one advantage of Star Topology of network. Also, illustrate how 5 computers can be connected with each other using star topology of network. 1
- (e) Granuda Consultants are setting up a secured network for their office campus at Faridabad for their day to day office and web based activities. They are planning to have connectivity between 3 building and the head office situated in Kolkata. Answer the questions (e1) to (e4) after going through the building positions in the campus and other details, which are given below. 4

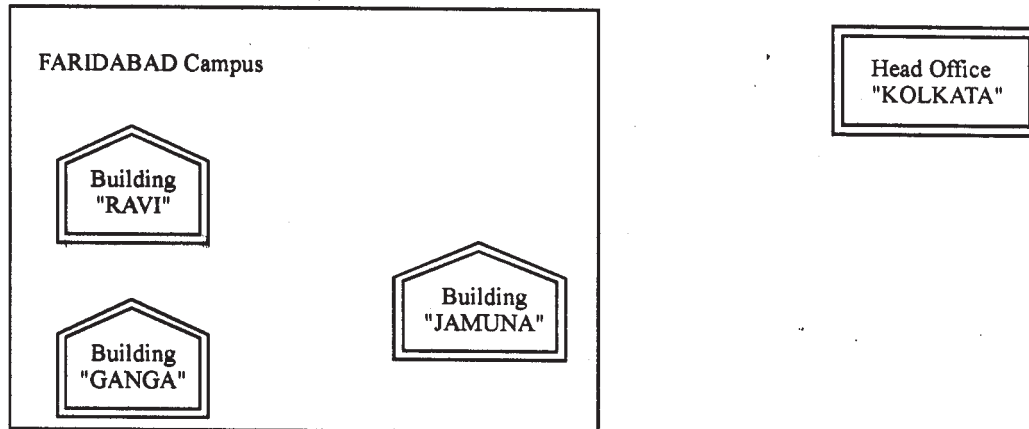

**Distances between various buildings :**

Building "RAVI" to Building "JAMUNA"	120 m
Building "RAVI" to Building "GANGA"	50 m
Building "GANGA" to Building "JAMUNA"	65 m
Faridabad Campus to Head Office	1460 KM

**Number of Computers**

Building "RAVI"	25
Building "JAMUNA"	150
Building "GANGA"	51
Head Office	10

- (e1) Suggest the most suitable place (i.e. block) to house the server of this organization. Also give a reason to justify your suggested location.
- (e2) Suggest a cable layout of connections between the building inside the campus.
- (e3) Suggest the placement of the following devices with justification
- (i) Switch
  - (ii) Repeater
- (e-4) The organization is planning to provide a high speed link with its head office situated in the KOLKATA using a wired connection. Which of the following cable will be most suitable for this job?
- (i) Optical Fibre
  - (ii) Co-axial Cable
  - (iii) Ethernet Cable

- (f) Give one suitable example of each- URL and Domain Name 1
- (g) Name two Open Source software alongwith its application 1

### QUESTION PAPER CODE 91

- 1 (a) Give the difference between the type casting and automatic type conversion. Also, give a suitable C++ code to illustrate both. 2
- (b) Which C++ header file(s) are essentially required to be included to run/execute the following C++ source code (Note: Do not include any header file, which is/are not required): 1

```
void main ()
{
    char TEXT [] = "Something";
    cout << "Remaining SMS Chars : "<< 160 - strlen (TEXT) << endl.;
}
```

- (c) Rewrite the following program after removing the syntactical errors (if any). Underline each correction. 2

```
#include <iostream.h>
Class Item
{
    long IID, Qty;
public :
    void Purchase{cin>>IID>>Qty;}
    void Sale ( )
    {
        cout<<setw(5) <<IID<<"Old:"<<Qty<<endl;
        cout<<' 'New: " <<Qty<<endl;
    }
} ;
```



```

void main ( )
{
    Item I ;
    Purchase ( ) ;
    I.Sale ( ) ;
    I.Sale ( )
}

```

(d) Find the output of the following program:

3

```

#include <iostream.h>
class METRO
{
    int Mno,TripNo,PassengerCount;
public:
    METRO(int Tmno=1) {Mno=Tmno;TripNo=0;PassengerCount=0;}
    void Trip(int PC=20) {TripNo++;PassengerCount+=PC; }
    void status Show ()
        {cout<<Mno<<": "<<TripNO<<": "<<PassengerCount<<endl;}
};
void main ()
{
    METRO M(5), T;
    M. Trip ( ) ;
    M. StatusShow() ;
    T. StatusShow() ;
    M. Status Show ( ) ;
}

```

- (e) Find the output of the following program:

2

```
#include <iostream.h>
#include <ctype.h>
typedef char str80 [80] ;
void main ( )
{
    char *Notes ;
    str80 str="vR2Go0D";
    int L=6;
    Notes=Str;
    while (L>=3)
    {
        Str[L]=(isupper(Str[L])?tolower(Str[L]):
        toupper(Str[L]));
        cout<<Notes<<endl;
        L--;
        Notes++;
    }
}
```

- (f) Observe the following program and find out, which output(s) out if (i) to (iv) will not be expected from the program? What will be the minimum and the maximum value assigned to the variable Chance?

2

```
#include <iostream.h>
#include <stdlib.h>
void main ( )
{
    randomize( ) ;
```

```

int Arr[]={9,6}, N;
int Chance=random(2) + 10 ;
for (int C=0;C<2;C++)
{
    N=random (2) ;
    cout<<Arr [N] + Chance<<"#";
}
}

```

- (i) 9#6#
- (ii) 19#17#
- (iii) 19#16#
- (iv) 20#16#

- 2 (a) What is the difference between the members in private visibility mode and the members in protected visibility mode inside a class? Also, give a suitable C++ code to illustrate both. 2
- (b) Answer the questions (i) and (ii) after going through the following class 2

```

class Travel
{
    int PlaceCode; char Place[20] ; float Charges;
public:
    Travel () //Function 1
    {
        PlaceCode=1;strcpy (Place, "DELHJ:") ; Charges = 1000;
    }
    void TravelPlan (float C) //Function 2
    {

```

```

        cout<<PlaceCode<<": " <<Place<<": " <<Charges<<endl;
    }
    ~Travel ( )                //Function 3
    {
        Cout<<"Travel Plan Cancelled"<<endl;
    }
    Travel (int PC, char P[], float C) //Function 4
    {
        PlaceCode=PC;strcpy (Place, P) ; Charges=C;
    }
} ;

```

- (i) In Object Oriented Programming, what are Function 1 and Function 4 combined together referred as?
- (ii) In Object Oriented Programming, which concept is illustrated by Function 3? When is this function called/invoked?
- (c) Define a class RESTRA in C++ with following description :

4

Private Members

- FoodCode of type int
- Food of type string
- FType of type string
- Sticker of type string
- A member function GetSticker () to assign the following value for Sticker as per the given FType:

FType	Sticker
Vegetarian	GREEN
Contains Egg	YELLOW
Non-Vegetarian	RED

### Public Members

- A function GetFood () to allow user to enter values for FoodCode. Food, FType and call function GetSticker() to assign Sticker.
- A function ShowFood() to allow user to view the content of all the data members.

(d) Answer the questions (i) to (iv) based on the following:

4

```
class COMPANY
{
    char Location[20] ;
    double Budget, Income ;
protected:
    void Accounts () ;
public:
    COMPANY () ;
    void Register();
    void Show() ;
} ;
class FACTORY:public COMPANY
{
    char Location[20] ;
    int Workers;
protected:
    double Salary ;
    void Computer() ;
public:
    FACTORY () ;
```

```

        void Enter ( ) ;
        void Show() ;
    } ;
class SHOP:private COMPANY
{
    char Location[20] ;
    float Area;
    double Sale;
public:
    SHOP ( ) ;
    void Input ( ) ;
    void Output ( ) ;
} ;

```

- (i) Name the type of inheritance illustrated in the above C++ code.
  - (ii) Write the name of data members, which are accessible from member functions of class SHOP.
  - (iii) Write the names of all the member functions, which are accessible from objects belonging to class FACTORY.
  - (iv) Write the names of all the members, which are accessible from objects of class SHOP
3. (a) Write a function SWAP2BEST (int ARR[], int Size) in C++ to modify the content of the array in such a way that the elements, which are multiples of 10 swap with the value present in the very next position in the array.

3

For example:

If the content of array ARR is

90, 56, 45, 20, 34, 54

The content of array ARR should become

56, 90, 45, 34, 20, 54

- (b) An array T[20][10] is stored in the memory along the column with each of the elements occupying 2 bytes. Find out the memory location of T[10][5], if the element T[2][9] is stored at the location 7600. 3
- (c) Write a function in C++ to perform Insert operation in a static circular Queue containing Book's information (represented with the help of any array of structure BOOK) 4
- ```

struct BOOK
{
    long Accno;           //Book Accession Number
    char Title [20]      //Book Title
};

```
- (d) Write a function ALTERNATE (int A[ ][3], int N, int M) in C++ to display all alternate elements from two-dimensional array A (starting from A[0][0]). 1
- For example:
- If the array is containing:
- ```

23  54  76
37  19  28
62  13  19

```
- The output will be
- ```

23  76  19  62  19

```
- (e) Evaluate the following POSTFIX notation. Show status of Stack after every step of evaluation (i.e. after each operator): 2
- True, False, NOT, AND, False, True, OR, AND
- 4 (a) Observe the program segment given below carefully and the questions that follow: 1
- ```

class Stock
{
    int I:no, Qty ; char I:tem [20];
public:

```

```

void Enter() {cin>>I:no;gets(I:tem) ; cin>>Qty;}
void issue(int Q){Qty+=Q;}
void Purchase(int Q){Q-=Q;}
int GetIno () {return Ino;}
};
void PurchaseItem(int Pino,int PQty)
{
fstream File;
File.open("STOCK.DAT", ios::binary|ios: :in|ios: :out);
Stock S;
int Success=0;
while (Success==0 && File.read((char*)&S,sizeof(S)))
{
    if (Pino==S. GetIno())
    {
        S.PurchaSe (PQ)      ;
        _____          // Statement 1
        _____          // Statement 2
        Success++;
    }
}
}
if (Success=1)
    Cout<<"Purchase Updated"<<endl;
else
    Cout<<' 'Wronq I:tem No"<<endl;
File.close() ;
}

```



- (i) Write statement 1 to position the file pointer to the appropriate place so that the data updation is done for the required item.
- (ii) Write statement 2 to perform the write operation so that the updation is done in the binary file.
- (b) Write a function in C++ to read the content of a text file "DELHI.TXT" and display all those lines on screen, which are either starting with 'D' or starting with 'M' 2
- (c) Write a function in C++ to search for the details (Phone no and Calls) of those Phones, which have more than 800 calls from a binary file "phones.dat" Assuming that this binary file contains records/objects of class Phone, which is defined below. 3

```
class Phone
{
    char Phoneno [10] ; int Calls ;
public:
    void Get () {gets (Phoneno) ; cin>>Calls;}
    void Billing() {cout<<Phoneno<<"#"<<Calls<<endl;}
    int GetCalls () {return Calls;}
} ;
```

- 5 (a) Give a suitable example of a table with sample data and illustrate Primary and Alternate Keys in it. 2

Consider the following tables CARDEN and CUSTOMER and answer (b) and (c) parts of this question:

**Table: CARDEN**

Ccode	CarName	Make	Color	Capacity	Charges
501	A-Star	Suzuki	RED	3	14
503	Indigo	Tata	SILVER	3	12
502	Innova	Tovota	WHITE	7	15
509	SX4	Suzuki	SILVER	4	14
510	C Class	Mercedes	RED	4	35

**Table: CUSTOMER**

CCode	Cname	Ccode
1001	Hemant Sahu	501
1002	Raj Lal	509
1003	Feroza Shah	503
1004	Ketan Dhal	502

(b) Write SQL commands for the following statements: 4

- (i) To display the names of all silver colored Cars.
- (ii) To display name of car, make and capacity of cars in descending order of their sitting capacity.
- (iii) To display the highest charges at which a vehicle can be hired from CARDEN.
- (iv) To display the customer name and the corresponding name of the cars hired by them.

(c) Give the output of the following SOL queries: 2

- (i) `SELECT COUNT (DISTINCT Make) FROM CARDEN;`
- (ii) `SELECT MAX (Charges), MIN (Charges) FROM CARDEN;`
- (iii) `SELECT COUNT (*), Make FROM CARDEN;`
- (iv) `SELECT CarName FROM CARDEN WHE~ Capacity = 4;`

6. (a) Verify the following using truth table: 2

- (i)  $X, X' = 0$
- (ii)  $X+1=1$

(b) Write the equivalent Boolean expression for the following Logic Circuit: 2

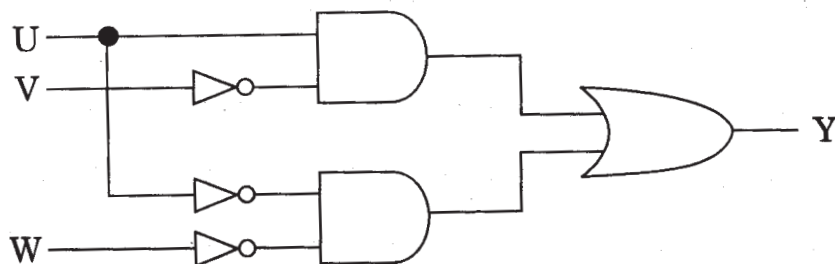

- (c) Write the SOP form of a Boolean function F, which is represented in a truth table as follows:

1

X	Y	Z	F
0	0	0	1
0	0	1	0
0	1	0	1
0	1	1	0
1	0	0	1
1	0	1	0
1	1	0	0
1	1	1	1

- (d) Reduce the following Boolean Expression using K-Map:

3

$$F(A, B, C, D) = (2, 3, 4, 5, 6, 7, 8, 10, 11)$$

- 7 (a) What out of the following, will you use to have an audio-visual chat with an expert sitting in a far-away place to fix-up a technical issue?

1

(i) VoIP

(ii) Email

(iii) FTP

- (b) Name one server side scripting language and one client side scripting language.

1

- (c) Which out of the following comes under Cyber Crime?

1

(i) Operating someone's Internet banking account, without his knowledge.

(ii) Stealing a keyboard from someone's computer.

(iii) Working on someone's computer with his/her permission.

- (d) Write one advantage of Bus Topology of network. Also, illustrate how 4 computers can be connected with each other using star topology of network.

2

- (e) Workalot Consultants are setting up a secured network for their office campus at Gurgaon for their day-to-day office and web-based activities. They are planning to have connectivity between 3 buildings and the head office situated

in Mumbai Answer the questions (i) to (iv) after going through the building positions in the campus and other details, which are given below:

3

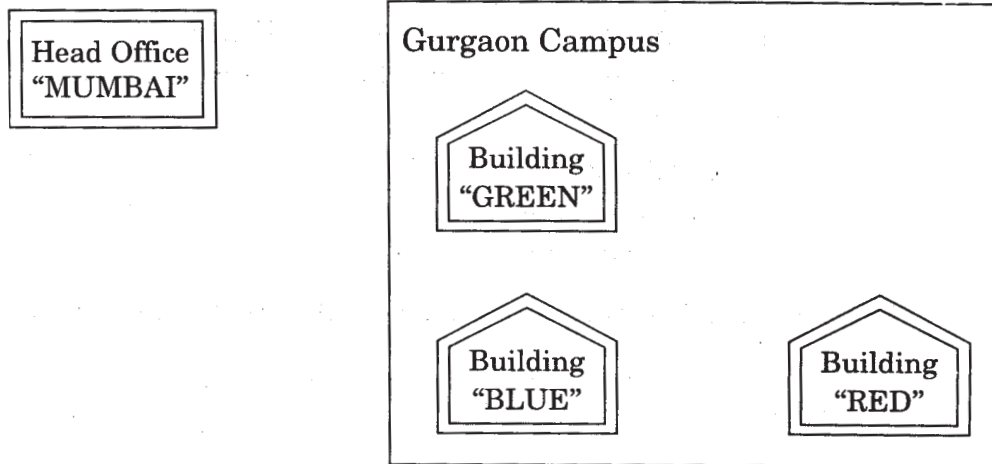

**Distances between various buildings**

Building "GREEN" to Building "RED"	110 m
Building "GREEN" to Building "BLUE"	45 m
Building "BLUE" to Building "RED"	65 m
Gurgaon Campus to Head Office	1760 KM

**Number of Computers**

Building "GREEN"	32
Building "RED"	150
Building "BLUE"	45
Head Office	10

- (i) Suggest the most suitable place (Le. building) to house the server of this organization. Also give a reason to justify your location.
- (ii) Suggest a cable layout of connections between the buildings inside the campus.
- (iii) Suggest the placement of the following devices with justification:
  - (1) Switch
  - (2) Repeater

- (iv) The organization is planning to provide a high speed link with its head office situated in the MUMBAI using a wired connection. Which of the following cable will be most suitable for this job?
- (i) Optical Fibre
  - (ii) Co-axial Cable
  - (iii) Ethernet Cable
- (f) Give one suitable example of each URL and Domain Name 1
- (g) Name two Proprietary softwares along with their application. 1

## Marking Scheme — Computer Science

### *General Instructions :*

- Marking scheme is the final document for all references with regard to evaluation and cannot be altered under any circumstances
- The answers given in the marking scheme are SUGGESTIVE. Examiners are requested to award marks for all alternative correct Solutions/Answers conveying the similar meaning
- All programming questions have to be answered with respect to C++ Language only
- In C++, ignore case sensitivity for identifiers (Variable/Functions/Structures/Class Names)
- In SQL related questions - both ways of text/character entries should be acceptable for Example: "DIVYA" and 'divya' both are correct.
- In SQL related questions - all date entries should be acceptable for Example: 'YYYY-MM-DD', 'DD-Mon-YYYY', 'DD/MMIYY', 'DD/MMIYY', 'MM/DDIYY', 'MM/DDIYY' and {MM/DDIYY} are correct.
- In SQL related questions - semicolon should be ignored for terminating the SQL statements.
- In SQL related questions, ignore case sensitivity.
- In SQL related outputs, ignore Column Headings.

QUESTION PAPER CODE 91/1

### EXPECTED ANSWERS

- 1 (a) Difference between the formal parameters and actual parameters. Also, give a suitable C++ code to illustrate both.

2

Ans	Formal Parameters	Actual Parameters
	The parameters mentioned in the function header are called the formal parameters. In the following example, parameter n is the formal parameter.	Values/Variables which are used while making a call to the function are called actual parameters. In the following example, variable num is an actual parameter.

```
#include <iostream.h>
```

```
long Fact (long n)
```

Formal  
Parameter

```

{
    long f=1;
    for(int i=1;i<=n; i++)
        f *= i;
    return f;
}

void main () {
    long num;

    cout<<"Enter a number:";

    cin>>num;

    cout<<n<<"!="<<Fact(num),
}

```



*(½ Mark for each correct explanation of Formal Parameter and Actual Parameter)*

*(½ Mark for each correct example of Formal Parameter and Actual parameter)*

**OR**

*(2 Marks for correct example(s) demonstrating the meaning of / difference between Formal and Actual Parameter)*

**OR**

*(Only 1 Mark to be awarded if Explanation without supporting examples)*

- (b) Which C++ header file(s) are essentially required to be included to run/execute the following C++ source code (Note: Do not include any header file, which is/are not required):

```

{
char STRING []="SomeThing";

cout<<"Balance Characters:"<<160-strlen(STRING)<<endl;

}

```

Ans `iostream.h/iomanip.h`  
`string.h`

*(½ Mark for writing each correct header file)*

***NOTE: Marks should not be deducted for mentioning extra header files in. addition to the ones mentioned above***

- (c) Rewrite the following program after removing the syntactical errors (if any).  
Underline each correction.

2

```
#include<iostream.h>

class BOOK
{
    long BId,Qty;
Public:
    void Purchase() {cin>>BId>>Qty;}
    void Sale
    {
        cout<<setw(5)<<BId<<"Old:"<<Qty<<endl;
        cout<<"New: " <<--Qty<<endl;
    }
};

void main ()
{
    BOOK B;
    B.Purchase() ;
    Sale ();
    B. Sale ()
}
```



```

Ans #include<iostream.h>
class BOOK
{
    long BId,Qty;
Public:
public:
    void Purchase() {cin>>BId>>Qty;}
    void Sale Sale()
    {
        cout<<setw(5)<<BID<<"Old:"<<Qty<<end;
        cout<<"New:"<<--Qty<<end;
    };
void main ()
{
    BOOK B;
    B. Purchase () ;
    Sale () ;
    B. Sale () ;
}

```

Either the statement removed or header file included as #include<iomanip\_h>

Either the statement removed or replaced with B. Sale ()

*(1/2 Mark for each of any four corrections out of five corrections shown above)*

**OR**

*(1 Mark for only identifying any four errors)*

**NOTE: Marks should not be deducted for mentioning any other error/correction**

(d) Find the output of the following program:

3

```

# include<iostream.h>
class TRAIN

```

```

{
    int Tno, TripNo, PersonCount;
public:
    TRAIN(int Tmno=1) {Tno=Tmno;TripNo=0;PersonCount=0;}
    void Trip(int TC=100) {TripNo++;PersonCount+=TC;}
voidShow() {cout<<Tno<<": "<<TripNo<<": "<<PersonCount<<endl;}
};
void main ( )
{
    TRAIN T(10) ,N;
    N. Trip ();
    T . Show ();
    T.Trip(70);
    N.Trip(40);
    N. Show ();
    T . Show ();
}

```

Ans	<i>(Full 3 Marks)</i>	<i>(2½ Marks)</i>	<i>(2½ Marks)</i>
	10:0:0	10 0 0	10:0:0 1:2:140 10:1:70
	1:2:140	1 2 140	
	10:1:70	10 1 70	

*(1 Mark for each correct line of output)*

**OR**

*(½ Mark to be awarded for writing only two of the correct values in each line)*

**NOTE:**

*Deduct ½ Mark for not writing any/all: and/or for not considering end / at proper places*

(e) Find the output of the following program:

2

```
#include<iostream.h>
#include<ctype.h>
typedef char Txt80 [80];
void main ( )
{
    Char *PTexti
    Txt80 Txt="Ur2GReAt ";
    int N=6;
    PText=Txt;
    while (N>=3)
    {
        Txt [N] = (isupper (Txt [N]) ? tolower (Txt [N] ) : toupper (Txt [N] ) );
        cout<<PText<<endl;
        N--;
        PText++;
    }
}
```

Ans Option 1:

<i>Full 2 Marks</i>	<i>1½ Marks</i>	<i>(1½ Marks)</i>	<i>(1½ Marks)</i>
Ur2GReat	U	Ur2GReat	Ur2GReAt
r2GREat	r	Ur2GREat	r2GReAt
2GrEat	2	Ur2GrEat	2 GReAt
great	G	Ur2grEat	GReAt

OR

Option 2:

NO OUTPUT

AND/OR

Option 3:

INCORRECT SYNTAX FOR char \*PText AND/OR

INCORRECT SYNTAX FOR tolower(Txt[N])

*(1/2 Mark for each correct line of Output for Option 1)*

**OR**

*(2 Marks for writing either of Option 2/3 Or any equivalent answer conveying same meaning as Option 2/3)*

- (f) Observe the following program and find out, which output(s) out of (i) to (iv) will not expected from the program? What will be the minimum and the maximum value assigned to the variable Chance?

2

```
#include <iostream.h>
#include <stdlib.h> void main ( )
{
    randomize ( )
    int Game []={10,16} , P;
    int Turn=random(2)+5;
    for(int T=0; T<=2; T++)
    {
        P=random (2) ;
        Cout<<Game [P]+ Turn<<"*";
    }
}
```

(i) 15 # 22 #

(ii) 22 # 16 #

(iii) 16 # 21 #

(iv) 21 # 22 #

Ans Option 1:

None of the outputs are correct

Variable named Chance does not exist in the program, hence no minimum and maximum values for it.

OR

Option 2:

Error in question

OR

Option 3: (Assuming

cout<<Game[P]+ Turn<<"#"; in place of cout<<Game[P]+ Turn<<"\*";)

If random(2) in int Turn=random(2)+5; generates 0 then Turn = 5		If random(2) in int Turn=random(2)+5; generates 1 then Turn = 6	
If P=random (2) ; Generates 0	If P=random(2) ; Generates 1	If P=random(2) ; Generates 0	If P=random (2) ; Generates 1
cout<<Game[P]+ Turn<<"#"; will give the output as 15#	cout<<Game[P]+ Turn<<"#"; will give the output as 21#	cout<<Game[P]+ Turn<<"#"; will give the output as 16#	cout<<Game[P]+ Turn<<"#"; will give the output as 22#
Thus for Turn =5 the output can be 15#15# OR 21#21# OR 15#21# OR 21#15#		Thus for Turn =6 the output can be 16#16# OR 22#22# OR 16#22# OR 22#16#	

Since out of the above possible outputs only option (ii) is correct, hence

The outputs not expected from the program are (i) (iii) and (iv)

**(Full 2 Marks for any of the above Options)**

**NOTE:**

**No marks for any other answer.**

2. (a) What is the difference between the members in private visibility mode and the members in public visibility mode inside a class? Also, give a suitable C++ code to illustrate both.

2

Private Visibility	Public Visibility
Members in private visibility mode are not accessible to the objects of class (They are only accessible inside the class to the member functions of the class).	Members in public visibility mode of the class are accessible to the objects of the class

```
#include <iostream.h>
#include<stdio.h>
const int Max=20;
class Hospital
{
    int Pno,Wardno;
    char Name [20] ;
public:
    void Register() {cin>>Pno; gets(Neme);cin>>Wardno;}
    void ShowStatus() { cout<<Pno<<Name<<Wardno<<endl;}
} ;
void main ( )
{
```

Members in Private Visibility Mode, accessible only to the member functions of same class

```

Hospital P1, P2;
P1.Register() ; P2.Register();
P1.Showstatus(); P2.Showstatus();

cin>>P1.Wardno; //NOT ACCESSIBLE as Wardno a a private member
cin>>P2.Pno; //NOT ACCESSIBLE as Pno is is a private member
}

```

Public members can be accessed by Objects of the class from outside the class

**(1 Mark for correct explanation OR example illustrating non accessibility of Private member(s) anywhere except within member function(s) of same class)**

**(1 Mark for correct explanation OR example illustrating accessibility of Public member(s) to the object(s) of the class and/or inside derived class member function(s))**

**OR**

**(2 marks to be awarded if private and public visibility are explained in terms of Inheritance with suitable example)**

- (b) Answer the questions(i) and (ii) after going through the following class: 2

```

class Tour
{
    int LocationCode;char Location[20];float Charges;

public:
    Tour() //Function 1
    {
        LocationCode=1; strcpy(Location, "PURI"); Charges=1200;
    }

    void TourPlain(float C) //Function 2
    {
        cout<<PlaceCode<<": "<<Place<<": "<<Charges<<endl;
        Charge+=100;
    }
}

```

```

    }
    Tour(int LC, char L[], float C) {          //Function 3
        LocationCode=LC; strcpy (Location,L); Charges=C;
    }
    ~Tour ( )                                //Function 4
    {
        cout<<"Tour Plan Cancelled"<<endl;
    }
} ;

```

- (i) In Object Oriented Programming, what are Function 1 and Function 3 combined together referred as?

Ans. (i) Polymorphism

OR

Constructor Overloading

OR

Overloaded Constructor

OR

Function Overloading

OR

Overloaded Functions

OR

Default Constructor and Parameterized Constructor

*(1 Mark for writing the feature name correctly)*

*NOTE: ½ mark for writing only constructor(s)*

- (ii) In Object Oriented Programming, which concept is illustrated by Function 4? When is this function called/invoked?



Ans. (ii) Destructor. It is called/invoked, when an object of the class goes out of scope.

*(½ Mark for writing the correct concept name)*

*(½ Mark for writing correct invocation)*

*NOTE: 1 Mark to be given if only the correct invocation is written*

(c) Define a class SUPPLY in C++ with following description:

4

Private Members

- Code of type int
- Food Name of type string
- Sticker of type string
- Food Type of type string
- A member function Get Type ( ) to assign the following values for

Food Type as per the given Sticker:

Sticker	Food Type
GREEN	Vegetarian
YELLOW	Contains Egg
RED	NON-Vegetarian

Public Members

- A function FoodIn ( ) to allow user to enter values for Code, FoodName, Sticker and call function Get Type ( ) to assign respective FoodType.
- A function FoodOut ( ) to allow user to view the content of all the data members.

Ans `class SUPPLY`

```
{  
  
    int Code;  
  
    char FoodName [20] ;  
  
    char Sticker [10] ;
```

```

        char FoodType[20];
        void GetType();
public:
        void FoodIn();
        void FoodOut();
};
void SUPPLY::GetType()
{
    if (strcmp (Sticker, "GREEN")==0)
        strcpy(FoodType, "Vegeterian");
    else
        if (strcmp (Sticker, "YELLOW") =0)
            strcpy(FoodType, "Contains Egg");
        else
            if (strcmp(Sticker, "RED")==0)
                strcpy(FoodType, "Non-Vegeterian");
}
void SUPPLY::FoodIn()
{
    cin>>Code;
    gets (FoodName);
    gets (Sticker);
    GetType();
}
void SUPPLY:: FoodOut()
{
    cout<<Code<<FoodName<<Sticker<<FoodType<<endl;
}

```

*(1/2 Mark for correct syntax for class header)*

*(1/2 Mark for correct declaration of data members)*

*(1 Mark for correct definition of GetType())*

*(1 Mark for correct definition of Food/nO with proper invocation of GetType() function)*

*(1 Mark for correct definition of FoodOut())*

**NOTE:**

- *1/2 Mark to be deducted if GetType() is not invoked properly inside Food/n() function*
- *No marks to be deducted if member function definitions are written inside the class*

(d) Answer the questions (i) to (iv) based on the following:

```
class ORGANIZATION
(
    char Address [20] ;
    double Budge, Income;
protected:
    void Computet () ;
public:
    ORGANIZATION () ;
    void Get () ;
    void Show () ;
} ;

class WORKAREA: Public ORGANIZATION
{
    char Address [20] ;
    int Staff;
```

```

protected:
    double Pay;
    void Calculate();

public:
    WORKAREA ();
    void Enter();
    void Display();
};

class SHOWROOM: Private ORGANIZATION
{
    char Address [20];
    void Enter();
    void Show();
};

```

(i) Name the type of inheritance illustrated in the above C++ code.

Ans Option 1:

Hierarchical Inheritance

OR

Option 2:

Single Level Inheritance

OR

Option 3:

Incorrect access specifier Public and Private used while inheriting

***(1 Mark for writing any of the Options or writing any equivalent answer for Option 3 conveying same meaning).***

(ii) Write the names of all the data members, which are accessible from member functions of class SHOWROOM

Ans Option 1:

Address, Area, Sale

Option 2:

Incorrect access specifier Private used while inheriting

(1 Mark for writing any of the Options or writing any equivalent answer for Option 2 conveying same meaning)

OR

(½ Mark for writing any two correct data members for Option 1) ,

(iii) Write the names of all the member functions, which are accessible from objects belonging to class WORKAREA.

Ans Option 1:

Enter (), Display (), Get (), Show ()

Option 2:

Incorrect access specifier Public used while inheriting

*(1 Mark for writing any of the Options or writing any equivalent answer for Option 2 conveying same meaning)*

OR

*(½ Mark for writing any two correct member functions for Option 1)*

(iv) Write the name of all the members, which are accessible from objects of Class SHOWROOM.

Ans Option 1:

Enter (), Show ()

Option 2:

Incorrect access specifier Private used while inheriting

*(1 Mark for writing any of the Options or writing any equivalent answer for Option 2 conveying same meaning)*

OR

*(½ Mark for writing anyone correct member function for Option 1)*

3. (a) Write a function SWAP2CHANGE (int p [ ], int N) in C++ to modify the content of the array in such a way that the elements, which are multiples of 10 swap with the value present in the very next position in the array.

For Example:

If the content of array P IS

3

91, 50, 54, 22, 30, 54

The content of array P should become

91,54,50,22,54,30

Ans void SWAP2CHANGE (int p[], int N)

```
{
    for(int i=0; i<N-1; i++)
    {
        if(p[i]%10==0)
        {
            int T = p[i];
            p[i] = p[i+1];
            p[i+1] = T;
            i++; //Ignore if not written
        }
    }
}
```

*(1/2 Mark for correct loop)*

*(1 Mark for checking array elements which are multiples of 10)*

*(1/2 Mark for swapping the element with value in the next position)*

NOTE:

Marks not to be deducted for running the loop till  $i < N$  instead of  $i < N - 1$

Marks not to be deducted for not incrementing  $i$  inside the body of the if construct

- (b) An array 5[10][30] is stored in the memory along the column with each of its element occupying 2 bytes. Find out the memory location of 5[5][10], if element 5[2][15] is stored at the location 8200.

3

Ans Option 1:

Assuming LBR=LBC=0

W=2 bytes, Number of Rows (M)=10, Number of Columns (N)=30

$$\text{LOC}(S[I] [J]) = B + (I + J * M) * W$$

$$\text{LOC}(S [2] [15]) = B + (2 + 15 * 10) * 2$$

$$8200 = B + (152 * 2)$$

$$B = 8200 - 304$$

$$B = 7896$$

$$\text{LOC}(S [5] [10]) = 7896 + (5 + 10 * 10) * 2$$

$$= 7896 + (105 * 2)$$

$$= 7896 + 210$$

$$= 8106$$

Option 2:

Assuming LBR=2, LBC=15 and B = 8200

W=2 bytes, Number of Rows (M)=10, Number of Columns (N)=30

$$\text{LOC}(S [I] [J]) = B + ((I - \text{LBR}) + (J - \text{LBC}) * M) * W$$

$$\text{LOC}(S [5] [10]) = 8200 + ((5 - 2) + (10 - 15) * 10) * 2$$

$$= 8200 + (3 + (-5) * 10) * 2$$

$$= 8200 + (3 + (-50)) * 2$$

$$= 8200 + (3 - 50) * 2$$

$$= 8200 + (-47) * 2$$

$$= 8200 - 94$$

$$= 8106$$

Option 3:

Assuming LBR=LBC=1

W=2 bytes, Number of Rows (M)=10, Number of Columns (N)=30

$$\text{LOC}(S [I] [J]) = B + ((I - \text{LBR}) + (J - \text{LBC}) * M) * W$$

$$\text{LOC}(S [2] [15]) = B + ((2 - 1) + (15 - 1) * 10) * 2$$

$$8200 = B + (141 * 2)$$

$$B = 8200 - 282$$

$$B = 7918$$

$$\text{LOC (S [5] [10])} = 7914 + ((5-1) + (10-1) * 10) * 2$$

$$= 7914 + (94 * 2)$$

$$= 7918 + 188$$

$$= 8106$$

***(1 Mark for writing correct formula (for column major) OR substituting formula with correct values for calculating Address)***

***(1 Mark for correct calculation)***

***(1 marks for writing correct address)***

***NOTE:***

- ***1 Mark to be awarded for writing only the correct answer (i.e. 8106)***
- ***2 Marks to be awarded if the formula and/or substitution is correct and total number of rows is considered as 11***
- ***Do not deduct any marks, if the formula/substitution is represented in any other equivalent form***

- (c) Write a function in C++ to perform Insert operation on a dynamic Queue containing DVD'S information (represented with the help of an array of structure DVD).

4

```
struct DVD
{
    long No; //DVD Nunber
    char Title[20]; //DVD Title DVD *Link;
} ;
```

Ans: class Queue

```
{
    DVD *Front, *Rear;
```



```

public:
    Queue ( )
    {
        Front = NULL;
        Rear = NULL;
    }
    void Insert() ;
    void Remove() ;
    void Display() ;
    ~Queue() ;
} ;

void Queue::Insert()
{
    DVD *T = new DVD;
    Cin>>T->No;
    gets (T->Title) ; //OR cin.getline(T->Title,20);
    T->Link = NULL;
    if (Rear=NULL)
    {
        Front = T;
        Rear = T;
    }
    else
    {
        Rear->Link = T;
        Rear = T;
    }
}

```

```
    }  
}
```

**OR**

*Code for array implemented queue will also be acceptable*

**OR**

*Code for dynamic array created in heap for a queue will be acceptable*

*(1 Mark for creating a new DVD dynamically)*

*(½ Mark for assigning NULL to Link of new DVD)*

*(½ Mark for checking Rear as NULL.*

*(½ Mark for assigning Rear and Fro'lt as Temp)*

*(1 Mark for linking the Rearmost NODE to the new NODE)*

*(½ Mark for making the new NODE as the Rearmost NODE)*

- (d) Write a function SKIPEACH (int H[] [3], int C, int R) in C++ to display all alternate elements from two - dimensional array H (starting from H [0] [0]).

2

For example:

If the array is containing:

12	45	67
33	90	76
21	43	59

The output will be

12	67	90	59
----	----	----	----

Ans void SKIPEACH(int H[] [3], int C, int R)

```
{  
    int N=0;  
    for (int I=0;I<R;I++)  
        for (int J=0;J<C;J++)  
        {  
            if (N%2=0)
```

```

        Cout<<H[I] [J] <<" ";
        N++;
    }
}

```

OR

```

void SKIPEACH(int H[1 [3], int C, int R)
{
    int *P=&H [0] [0] ;
    for (int I=0;I<C*R;I+=2)
    {
        Cout<<*P<<" ";
        P+=2;
    }
}

```

**OR**

**Any other equivalent correct answer acceptable**

*(1 Mark for writing correct loops starting for location [0][0])*

*(1/2 Mark for logic of checking alternate elements)*

*(1/2 Mark for displaying the alternate elements)*

- (e) Evaluate the following POSTFIX notation. Show status of Stack after every step of evaluation (i.e after each operation.)

False, NOT, True, AND, True, False, OR, AND

Ans Element Scanned Stack Status

False	False
NOT	True
True	True, True
AND	True
True	True, True
False	True, True, False
OR	True, True
AND	True

**Final Answer: True**

*(½ Mark for evaluating till NOT operator)*

*(½ Mark for evaluating till the next AND operator)*

*(½ Mark for evaluating till the next OR operator)*

*(½ Mark for evaluating till the fast AND Operator and Final Answer)*

**NOTE:**

*(1 Mark for only writing the final answer as True without showing the Stack Status)*

- 4 (a) Observe the program segment given below carefully and the questions that follow: 1

```
class Inventory
{
    int Ano, Qty; char Article [20] ;
public:
    void Input () {cin>>Ano; gets (Article) :cin>>Qty;}
    void Issue(int Q) {Qty+=Q;}
    void procure(int Q) {Qty-=Q;}
    int GetAno() {return Ano;}
} ;

void ProcureArticle (int TAno, int TQty)
{
    fstream File;
    File.open ("STOCK, DAT", ios::binary|ios::in|ios::out);
    Inventory I;
    int Found =0;
    while (Found ==0 && File.read<char*>&I, sizeof(I))
    {
        if (TAno == S. GetAno())
```

```

        {
            I. Procure (TQty) ;
            _____ // Statement 1
            _____ // Statement 2
            Found ++;
        }
    }
    if (Found == 1)
        cout<<"Procurement Updated"<<endl;
    else
        cout<<"Wrong Article No"<<endl.;
    File.close() ;
}

```

- (i) Write statement 1 to position the file pointer to the appropriate place, so that the data updation is done for the required Article.

Ans Option 1:

```
File.seekp(File.tellg() - .sizeof(Inventory)) ;
```

OR

```
File.seekp(-sizeof(Inventory) ,ios: :cur));
```

OR

```
File.seekp(File.tellg() - sizeof(I));
```

Option 2:

Incorrect use of object S to invoke GetAno ()

*(½ Mark for writing any of the above Options or writing an answer conveying same meaning as Option 2)*

**NOTE:**

*seekp() and seekg() may be used interchangeably for Option 1*

*tellp() and tellg() may be used interchangeably for Option 1*

- (ii) Write statement 2 to perform the write operation so that the updation is done in the binary file.

Ans Option 1:

```
File.write((char*)&I, sizeof(I));
```

OR

```
File.write((char*)&I, sizeof(Inventory));'
```

Option 2:

Incorrect use of object S to invoke GetAno ()

*(1/2 Mark for writing any of the above Options or writing an answer conveying same meaning as Option 2)* .

- (b) Write a function in C++ to read the content of a text file "PLACES.TXT" and display all those lines on screen, which are either starting with 'P' or starting with 'S'.

2

Ans void DispPorS ( )

```
{  
    ifstream File ("PLACES.TXT");  
    char STR[80]; while(File.getline(STR,80))  
    {  
        if(STR[0]=='P' || STR[0]=='S')  
            cout<<STR<<endl;  
    }  
    File.close(); //Ignore  
}
```

OR

**Any other correct function definition performing the desired operation**

*(1/2 Mark for opening PLACES. TXT correctly)*

*(1/2 Mark for reading each Line (Whichever method adopted) from the file)*

*(1/2 Mark for checking lines starting with 'P' or 'S')*

*(1/2 Mark for displaying the lines)*

**NOTE:**

***Ignore case sensitivity check for 'P' or 'S'***

- (c) Write a function in C++ to search for the details (Number and Calls) of those Mobile phones, which have more than 1000 calls from a binary file "mobile.dat". Assuming that this binary file contains records/objects of class Mobile, which is defined below:

3

```
class Mobile
{
    char Number [10]; int Calls;
public:
    void Enter() {gets (Number); cin>> Calls;}
    void Billing() {cout<< Number<<"#"<<Calls<<endl;}
    int GetCalls() {return Calls;}
} ;
```

Ans void Search ( )

```
{
    Mobile M;
    fstream fin;
    fin.open ("mobile.dat",1 ios::binaryllios::in);
    While(fin.read((char*)&M, Sizeof(M))
    {
        if(M.getCalls() > 1000)
            M. Billing ( ) ;
    }
    fin.close(); //Ignore
}
```

Ignore

**OR**

**Any other correct function definition performing the desired operation**

*(1/2 Mark for declaration of object using fstream/ifstream)*

*(1/2 Mark for opening mobile.dat correctly)*

*(1/2 Mark for reading record(s) from mobile.dat)*

*(1/2 Mark for correct formation of loop)*

*(1/2 Mark for checking if value returned by getCalls( ) > 1000)*

*(1/2 Mark for displaying the matching record)*

**NOTE:**

**Marks not to be deducted for the comparison as  $\geq 1000$**

5. (a) Give a suitable example of a table with sample data and illustrate Primary and Candidate Keys in it.

2

Ans A table may have more than one such attribute/group of attribute that identifies a row/tuple uniquely, all such attribute(s) are known as Candidate Keys. Out of the Candidate keys, one is selected as Primary Key,

Table: Stock

Ino	Item	Qty
I01	Pen	560
I02	Pencil	780
I04	CD	450
I09	Floppy	700
I05	Eraser	300
I03	Duster	200

The diagram shows a box labeled 'Primary' with a line pointing to the 'Ino' column of the table. Another box labeled 'Candidate Keys' has lines pointing to the 'Item' and 'Qty' columns of the table.

*(1 Mark for writing suitable example /correct definition of a table)*

*(1/2 Mark for correct illustration / definition of Candidate Keys)*

*(1/2 Mark for correct illustration / definition of Primary Key)*



Consider the following tables CABHUB and CUSTOMER and answer (b) and (c) parts of this question:

Table: CABHUB

Vcode	VehicleName	Make	Color	Capacity	Charges
100	Innova	Toyota	WHITE	7	15
102	SX4	Suzuki	BLUE	4	14
104	C Class	Mercedes	RED	4	35
105	A-Star	Suzuki	WHITE	3	14
108	Indigo	Tata	SILVER	3	12

Table : CUSTOMER

CCode	CName	Vcode
1	Hemant Sahu	101
2	Raj Lal	108
3	Feroza Shah	105
4	Ketan Dhal	104

(b) Write SQL commands for the following statements:

4

(i) To display the names of all the white colored vehicles.

Ans. SELECT VehicleName FROM CABHUB

WHERE Color = 'WHITE';

*(1 Mark for correct query)*

*(½ Mark for partially correct answer)*

(ii) To display name of vehicle, make and capacity of vehicles in ascending order of their sitting capacity.

Ans. SELECT vehicleName, Make, Capacity FROM CABHUB

ORDER BY Capacity;

*(1 Mark for correct query)*

*(½ Mark for partially correct answer)*

(iii) To display the highest charges at which a vehicle can be hired from CABHUB.

Ans. SELECT MAX (Charges) FROM CABHUB;

*(1 Mark for correct query)*

*(½ Mark for partially correct answer)*

- (iv) To display the customer name and the corresponding name of the vehicle hired by them.

Ans. `SELECT CName, VehicleName FROM CUSTOMER, CABHUB`

`WHERE CUSTOMER.Vcode = CABHUB.Vcode;`

OR .

`SELECT CUSTOMER.CName, CABHUB.VehicleName FROM CUSTOMER, CABHUB`

`WHERE CUSTOMER.Vcode = CABHUB.Vcode;`

OR

`SELECT :Name, VehicleName FROM CUSTOMER A, CABHUB B`

`WHERE A Vcode = B.Vcode;`

OR

`SELECT A.CName, B.VehicleName FROM CUSTOMER A, CABHUB B`

`WHERE A.Vcode = B.Vcode;`

***(1 Mark for correct query)***

***(1/2 Mark for partially correct answer)***

- (c) Give the output of the following SQL queries:

- (i) `SELECT COUNT (DISTINCT Make) from CABHUB;`

2

Ans. 

COUNT(DISTINCT Make)
4

***(1/2 Mark for correct output)***

- (ii) `SELECT MAX (Charges), MIN (Charges) FROM CABHUB;`

Ans. 

MAX (Chrges)	MIN (Charges)
35	12

***(1/2 Mark for correct output)***

- (iii) `SELECT count (*), Make FROM CABHUB;`

Ans. Option 1:

(Ignoring Make for display)

COUNT (*)
5

OR

(assuming the presence of GROUP BY Make)

COUNT (*)	Make
2	SUZUKI
1	TATA
1	TOYOTA
1	MERCEDES

OR

No Output

OR

Incorrect Syntax/Error/Query will not run

*(1/2 Mark for writing any of the above or any answer conveying same meaning)*

**OR**

*(1/2 Mark to be awarded if any two outputs out of (i) and (ii) are correct)*

(iv) SELECT Vehicle FROM CABHUB WHERE Capacity = 4;

Ans. (Assuming VehicieName in place of Vehicle)

VehicleName
SX4
C Class

OR

No Output

OR

Incorrect Attribute Name

*(1/2 Mark for writing any of the above or any answer conveying same meaning)*

**OR**

*(½ Mark to be awarded if any two outputs out of (i) and (ii) are correct)*

6. (a) Verify the following using truth table:

2

(i)  $X + 0 = X$

Ans.

x	x + 0
0	0
1	1

↑  
Verified

*(1 Mark for correct verification)*

**OR**

*(½ Mark for any two correct columns)*

(ii)  $X + X' = 1$

Ans.

X	X'	X + X'	1
0	1	1	→ 1
1	0	1	1

Verified

*(1 Mark for correct verification)*

**OR**

*(½ Mark for any two correct columns)*

(b) Write the equivalent Boolean Expression for the following Logic Circuit:

2

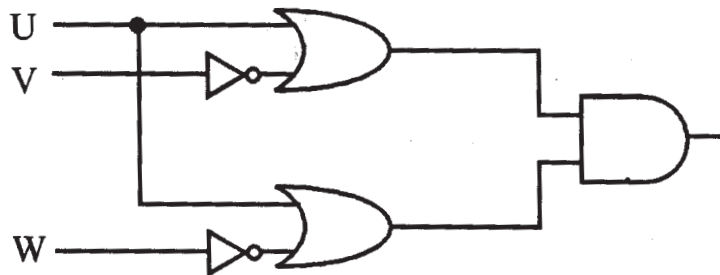

Ans.  $(U+V') \cdot (U+W')$

(2 Marks for the final expression  $(U+V') \cdot (U+W')$ )

OR

(1 Mark for anyone of the correct terms out of  $(U+V')$  or  $(U+W')$ )

(c) Write the POS form of a Boolean function G, which is represented in a truth table as follows:

1

A	B	C	G
0	0	0	0
0	0	1	1
0	1	0	1
0	1	1	0
1	0	0	0
1	0	1	0
1	1	0	1
1	1	1	1

Ans  $(A+B+C) \cdot (A+B'+C') \cdot (A'+B+C) \cdot (A'+B+C')$  OR  $G(X,Y,Z) = \sum(0,3,4,5)$

(1 Mark for the correct P form)  $\Sigma$

(1/2 mark for any two correct terms)

NOTE: Marks should not be deducted for any other variable names

(d) Reduce the following Boolean Expression using K-Map:

$F(P, Q, R, S) = (1, 2, 3, 4, 5, 6, 7, 8, 10)$

Ans

P'Q'	P'Q	PQ	PQ'
------	-----	----	-----

R'S'	0	1	4	12	8
R'S	1	1	5	13	
RS	1	1	7	15	11
RS'	1	1	6	14	10

**OR**

	R'S'	R'S	RS	RS'
P'Q'	0	1	1	2
P'Q	4	5	7	6
PQ	12	13	15	14
PQ'	8	9	11	10

$$F(P, Q, R, S) = P' Q + P' S + P' R + PQ' S'$$

*(1/2 Mark for placing all 1 s at correct positions in K-Map)*

*(1/2 Mark for each grouping)*

*(1/2 Mark for writing final expression in reduced/minimal form)*

**NOTE: marks should not be deducted for any other variable names**

7. (a) What out of the following, you will use to have an audio-visual chat with an expert sitting in a faraway place to fix-up a technical issue? 1

- (i) Email
- (ii) VoIP
- (iii) FTP

Ans (ii) VoIP

OR

None of the Options

*(1 Mark for writing correct option)*

- (b) Name one Client side scripting language and one Serverside scripting language. 1

Ans. Client side scripts: Java script/ VB script / Perl/ Tcl/ Tk/ REXX.

Server side scripts: JSP/ ASP/ PHP/ CGI/ Perl

*(1/2 Mark for writing one correct Client side scripting language name)*

*(1/2 Mark for writing one correct Server side scripting language name)*

(c) Which out of the following does not come under Cyber Crime?

1

- (i) Stealing a mouse from someone's computer.
- (ii) Operating someone's Internet Banking account, without his knowledge.
- (iii) Entering in someone's computer remotely and copying data, without seeking his permission.

Ans. (i) Stealing a mouse from someone's computer.

*(1 Mark for writing correct option)*

(d) Write one advantage of Star Topology of network. Also, illustrate how 5 computers can be connected with each other using star topology of network.

1

Ans. Independent line of connection allows freedom of removing or adding nodes from the network

OR

Any other correct advantage of Star Topology of network.

Illustration of 5 computers connected with each other using star topology of network.

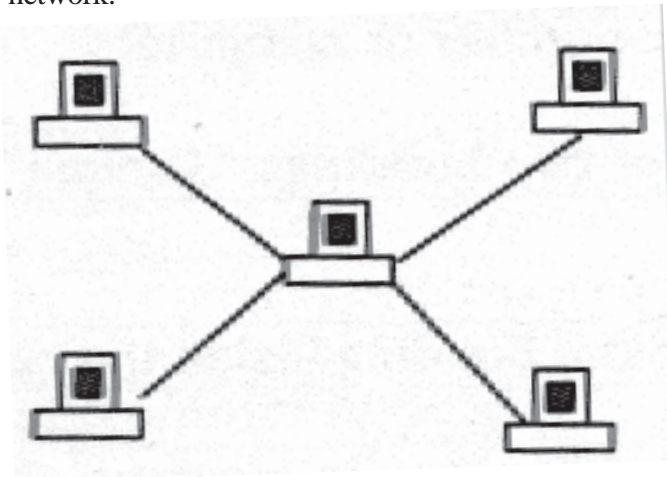

*(1/2 Mark for writing one correct advantage)*

*(1/2 Mark for drawing / writing correct illustration OR any other diagrammatic representation for star topology)*

(e) Granuda Consultants are setting up a secured network for their office campus at Faridabad for their day to day office and web based activities. They are planning to have connectivity between 3 building and the head office situated

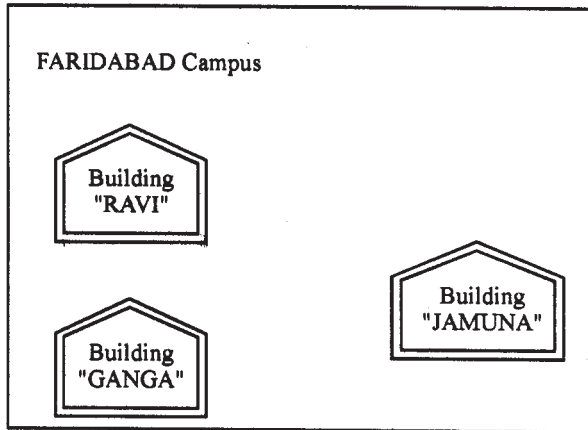

**Distances between various buildings :**

Building "RAVI" to Building "JAMUNA"	120 m
Building "RAVI" to Building "GANGA"	50 m
Building "GANGA" to Building "JAMUNA"	65 m
Faridabad Campus to Head Office	1460 KM

**Number of Computers**

Building "RAVI"	25
Building "JAMUNA"	150
Building "GANGA"	51
Head Office	10

in Kolkata. Answer the questions (e1) to (e4) after going through the building positions in the campus and other details, which are given below.

4

- (e1) Suggest the most suitable place (i.e. block) to house the server of this organization. Also give a reason to justify your suggested location.

Ans Building "Jamuna", since it contains maximum number of computers

OR

Building "Ganga", since it is closest to the other two buildings "Jamuna" and "Ravi"

*(1/2 Mark for writing any correct place)*

*(1/2 Mark for correct justification)*

- (e2) Suggest a cable layout of connections between the building inside the campus.



Ans

FARIDABAD Campus

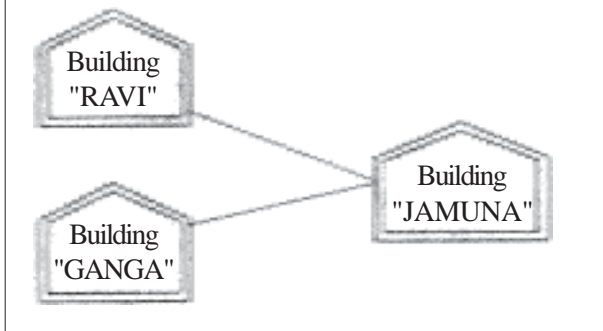

**OR**

FARIDABAD Campus

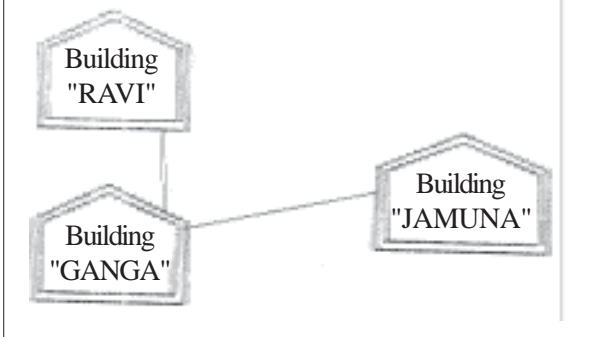

*(1 Mark for drawing /writing any valid connectivity or topology or diagram connecting various buildings inside the campus)*

**NOTE:** *Ignore placement/order of buildings in the diagrammatic representation*

(e3) Suggest the placement of the following devices with justification

- (i) Switch
- (ii) Repeater

Ans. (i) Switch:

In. each of the buildings, since. a network switch is a networking device that joins multiple computers together within one local area network (LAN).

(ii) Repeater:

For the Alternative 1 layout drawn in (e2)- Between buildings "Jamuna" and "Ravi", since distance between these two buildings is greater than

70 m which will otherwise lead to loss of signal intensity for data to be transferred.

For the Alternative 2 layout drawn in (e2): Repeater is not needed, since distance between both the buildings connected to "Ganga" is less than 70 m not leading to any signal loss'.

OR

Any other placement of Repeater with proper justification

*(½ Mark for writing correct placement and justification of Switch)*

*(½ Mark for writing correct placement and justification of Repeater, according to layout drawn for e2)*

(e-4) The organization is planning to provide a high speed link with its head office situated in the KOLKATA using a wired connection. Which of the following cable will be most suitable for this job?

- (i) Optical Fibre
- (ii) Co-axial Cable
- (iii) Ethernet Cable

Ans. (i) Optical Fibre

*(1 Mark for writing correct option)*

(f) Give one suitable example of each- URL and Domain Name

1

Ans. URL Example: <http://www.w3schools.com/html/default.asp>

OR

[www.youtube.com](http://www.youtube.com)

Domain Name Example: [w3schools.com](http://w3schools.com)

OR

Any other correct URL and Domain Name Examples

NOTE: Domain names in both the examples may/may not be same

*(½ Mark for writing any correct URL Example)*

*(½ Mark for writing any correct Domain Name Example)*

(g) Name two Open Source software alongwith its application

Ans GNU: It is an Operating System composed entirely of free software

OR

Open Office: It is an open-source office productivity software suite whose main components are for word processing, spreadsheets, presentations, graphics, and databases

OR

GIMP(GNU Image Manipulation Program): It is a free and open 'source software raster graphics editor

OR

Blender: It is a free and open-source 3D computer graphics software

OR

Any other correct Open Source Software with its application

(7/2 mark each for any 2 of the above mentioned or any other Open Source software with/or without their application areas)

"Kindly read the instructions written on Page no. 1 carefully"

### QUESTION PAPER CODE 91

### EXPECTED ANSWERS

- 1 (a) Give the difference between the type casting and automatic type conversion. Also, give a suitable C++ code to illustrate both.

2

Type Casting	Automatic Type Conversion
Explicitly converting an expression of a given type into another type is known as type-casting. Example: <code>float f=7.9;</code> <code>int c=(int) f;</code> <code>Cout&lt;&lt;c;</code> Output : 7	Implicitly converting data from one data type to another by assigning to a variable of another type. Example: <code>Char x=' A' ;</code> <code>Int c=x;</code> <code>Cout&lt;&lt;c;</code> Output 65

*(1/2 Mark for each correct explanation of Automatic Type Conversion and Type Casting)*

*(1/2 Mark for each correct example of Automatic Type Conversion and Type Casting)*

**OR**

*(Full 2 Marks for correct example(s) demonstrating the meaning of or difference between Automatic Type Conversion and Type Casting)*

**OR**

*(Only 1 1/2 Mark to be awarded if explanation without supporting examples)*

- (b) Which C++ header file(s) are essentially required to be included to run/execute the following C++ source code (Note: Do not include any header file, which is/are not required) :

1

```
void main ()  
{  
    char TEXT [] = "Something";  
    cout << "Remaining SMS Chars : " << 160 - strlen (TEXT) << endl.;  
}
```

Ans iostream.h/iomanip.h  
string.h

*(1/2 Mark for writing each correct header file)*

*Note: Marks should not be deducted for mentioning extra header files in addition to the ones mentioned above*

- (c) Rewrite the following program after removing the syntactical errors (if any). Underline each correction.

2

```
#include <iostream.h>  
  
Class Item  
{
```

```

        long IId, Qty;
public :
    void Purchase{cin>>IId>>Qty;}
    void Sale ( )
    {
        cout<<setw(5)<<IId<<"Old:"<<Qty<<endl;
        cout<<' 'New: "<<Qty<<endl;
    }
} ;
void main ( )
{
    Item I ;
    Purchase ( ) ;
    I.Sale ( ) ;
    I.Sale ( )
}

```

Ans #include<iostream.h>

```

class Item      // C Capital
{
    long IId,Qty;
public:
    void Purchase ( ){cin>>IId>>Qty;}
    void Sale ( )
    {
        Cout<<setw(5)<<IId<<" Old: "<<Qty<<endl;
        cout<<"New: "<<--Qty<<endl;
    }
}

```

Either the statement is removed  
or header file included as  
#include<iomanip.h>

```

    }
} ;
void main ( )
{
    Item I;
    I.Purchase( );// Object missing
    I. Sale ( ) ;
    I. Sale ( ) i           // ; is missing
}

```

*(1/2 Mark for each of any four corrections out of five corrections shown above)*

**OR**

*(1 Mark for only identifying any four errors)*

*Note: Marks should not be deducted for mentioning any other error/correction*

- (d) Find the output of the following program:

3

```

#include <iostream.h>
class METRO
{
    int Mno, TripNo, PassengerCount;
public:
    METRO(int Tmno=1) {Mno=Tmno; TripNo=0; PassengerCount=0;}
    void Trip(int PC=20) {TripNo++; PassengerCount+=PC; }
    void status Show ()
        {cout<<Mno<<": "<<TripNO<<": "<<PassengerCount<<endl;}
};
void main ()

```

```

{
    METRO M(5), T;
    M. Trip () ;
    M. StatusShow() ;
    T. StatusShow() ;
    M. Status Show () ;
}

```

Ans	(Full 3 Marks)	(2½ Marks)	(2½ Marks)
	5:1:20	5 1 20	5:1:20 1:1:50 5:2:50
	1:1:50	1 1 50	
	5:2:50	5 2 50	

*(1 Mark for each correct line of output)*

**OR**

*(½ Mark to be awarded for writing only two of the correct values in each line)*

**Note: Deduct ½ Mark for not writing any/all : and/or for not considering end / at proper places**

(e) Find the output of the following program:

2

```

#include <iostream.h>
#include <ctype.h>
typedef char str80 [80] ;
void main ( )
{
    char *Notes ;
    str80 str="vR2Go0D";
    int L=6;

```

```

Notes=Str;
while (L>=3)
{
    Str [L] = (isupper (Str [L] ) ?tolower (Str [L] ) :
    toupper (Str [L] ) ) ;
    cout<<Notes<<endl ;
    L-- ;
    Notes++;
}
}

```

Ans

<i>Full 2 Marks</i>	<i>1½ Marks</i>	<i>(1½ Marks)</i>	<i>(1½ Marks)</i>
vR2Good	v	vR2Good	vR2GooD
R2GoOd	R	vR2GoOd	R2GooD
2GOOd	2	vR2GOOd	2GooD
gOOd	g	vR2g00d	GooD

(½ Mark for each correct line of Output)

Note: ½ mark to be deducted if all the values are written in the same line

- (f) Observe the following program and find out, which output(s) out if (i) to (iv) will not be expected from the program? What will be the minimum and the maximum value assigned to the variable Chance?

2

```

#include <iostream.h>
#include <stdlib.h>
void main ( )
{
    randomize ( ) ;
    int Arr []={9,6}, N;
    int ChanoE=random(2) + 10 ;
}

```



```

for (int C=0;C<2;C++)
{
    N=random (2) ;
    cout<<Arr [N] + Chance<<"#";
}
}

```

- (i) 9#6#
- (ii) 19#17#
- (iii) 19#16#
- (iv) 20#16#

Ans The outputs not expected from the program are (i), (ii) and (iv)

Minimum Value of Chance = 10

Maximum Value of Chance = 11

*(1 Mark for writing correct option for output NOT expected)*

*(1/2 Mark for writing correct Minimum Value of Chance)*

*(1/2 Mark for writing correct Maximum Value of Chance)*

- 2 (a) What is the difference between the members in private visibility mode and the members in protected visibility mode inside a class? Also, give a suitable C++ code to illustrate both.

2

Ans Option 1

Private Visibility	Protected Visibility
Members in private visibility mode are not accessible to the objects of class (They are only accessible inside the class to the member functions of the class).	Members in protected visibility mode of the class are accessible to the member functions of the same as well as that of its derived class

Example:

```
#include <iostream.h> #include<stdio.h>
```

```
const int Max=20;
```

```
class Hospital
```

```
{
```

```
    int Pno;
```

Members in Private Visibility Mode, accessible only to the member functions of same class

```
protected:
```

```
    char Name [20] ;
```

Members in Protected Visibility Mode, accessible to the member functions of same class as well as in member functions of derived class

```
public:
```

```
void Register () {cin>>Pno; gets (Name) ;}
```

```
void ShowStatus () {cout<<Pno<<N&me<<WardnO<<endl ; }
```

```
} ;
```

Option 2:

Members are private by default inside a class

Protected visibility must be specified for a member to be declared as protected

Option 3:

No difference in accessibility of the members of the two visibility modes inside a class without inheritance

*For Option 1:*

***(1 Mark for correct explanation)***

*OR*

*For Option 2 and 3:*

***(Full 2 Marks for writing any answer conveying same meaning)***

*OR*

***(Full 2 Marks for correct explanation OR example illustrating accessibility of Protected Member(s) inside derived class member function(s))***

(b) Answer the questions (i) and (ii) after going through the following class

2

```
class Travel
{
    int PlaceCode; char Place[20] ; float Charges;
public:
    Travel ()                                //Function 1
    {
        PlaceCode=1;strcpy (Place, "DELHJ:"); Charges = 1000;
    }
    void TravelPlan (float C)                //Function 2
    {
        cout<<PlaceCode<<":"<<Place<<":"<<Charges<<endl;
    }
    ~Travel ()                               //Function 3
    {
        Cout<<"Travel Plan Cancelled"<<endl;
    }
    Travel (int PC, char P[], float C)       //Function 4
    {
        PlaceCode=PC;strcpy(Place,P); Charges=C;
    }
};
```

(i) In Object Oriented Programming, what are Function 1 and Function 4 combined together referred as?

Ans (i) Polymorphism

OR

Constructor Overloading

OR

Overloaded Constructor

OR

Function Overloading

OR

Overloaded Functions

OR

Default Constructor and Parameterized Constructor

*(1 Mark for writing the feature name correctly)*

**Note:**

*(1/2 mark for writing only "constructor(s)")*

- (ii) In Object Oriented Programming, which concept is illustrated by Function 3? When is this function called/invoked?

Ans. (ii) Destructor. It is called / Invoked when an object of the class goes out of scope.

*(1/2 Mark for writing the correct concept name)*

*(1/2 Mark for writing correct invocation)*

**Note:**

*(Full 1 Mark to be given if only the correct invocation is written)*

- (c) Define a class RESTRA in C++ with following description :

4

Private Members

- FoodCode of type int
- Food of type string
- FType of type string
- Sticker of type string

- A member function GetSticker () to assign the following value for Sticker as per the given FType:

FType	Sticker
Vegetarian	GREEN
Contains Egg	YELLOW
Non-Vegetarian	RED

#### Public Members

- A function GetFood () to allow user to enter values for FoodCode, Food, FType and call function GetSticker() to assign Sticker.
- A function ShowFood() to allow user to view the content of all the data members.

Ans class RESTRA

```
{
    int FoodCode;
    char Food[20], FType [20],Sticker[20];
    void GetSticker () ;

public:
    void GetFood () ;
    void ShowFood () ;
} ;

void RESTRA::GetSticker() {
    if (strcmp (FType, "Vegetarian") ==0)
        strcpy (Sticker,"GREEN") ;
    else if (strcmp (FType,"Contains Egg")==0)
        strcpy (Sticker, "YELLOW") ;
    else if (strcmp (FType,'Non-Vegetarian')==0)
        strcpy(Sticker,"RED");
}
```

```

}
void RESTRA::GetFood()
{
    cin>>FoodCode;
    gets (Food);
    gets (FType) ;
    GetSticker () ;
}
void RESTRA::ShowFood ()
{
    cout<<FoodCode<<" : "<<Food<<FType<<" : "<<Sticker<<endl;
}

```

*(½ Mark for correct syntax for class header)*

*(½Mark for correct declaration of data members)*

*(1 Mark for correct definition of GetSticker())*

*(1 Mark for correct definition of GetFood() with proper invocation of GetSticker() function)*

*(1 Mark for correct definition of ShowFood())*

**NOTE:**

- ½ Mark to be deducted if GetSticker() is not invoked properly inside GetFood()function
- No marks to be deducted if member function definitions are written inside the class

(d) Answer the questions (i) to (iv) based on the following:

4

```

class COMPANY
{
    char Location[20] ;
}

```

```

        double Budget, Income ;
protected:
        void Accounts () ;
public:
        COMPANY () ;
        void Register();
        void Show() ;
} ;
class FACTORY:public COMPANY
{
        char Location[20] ;
        int Workers;
protected:
        double Salary ;
        void Computer() ;
public:
        FACTORY () ;
        void Enter () ;
        void Show() ;
} ;
class SHOP:private COMPANY
{
        char Location[20] ;
        float Area;
        double Sale;
public:

```

```
SHOP () ;  
void Input ( ) ;  
void Output ( ) ;  
} ;
```

(i) Name the type of inheritance illustrated in the above C++ code.

Ans Hierarchical Inheritance

OR

Single Level Inheritance

*(1 Mark for writing correct answer)*

(ii) Write the name of data members, which are accessible from member functions of class SHOP.

Ans Location, Area, Sale

*(1 Mark for writing correct answer)*

OR

*(1/2 Mark for writing any two correct data members)*

(iii) Write the names of all the member functions, which are accessible from objects belonging to class FACTORY.

Ans Enter (), FACTORY::Show (), Register (), COMPANYY::Show ()

OR

Enter (), Show (), Register () // Show function may be present twice

OR

Enter, Show, Register

*(1 Mark for writing correct answer)*

OR

*(1/2 Mark for writing any two correct member functions)*

(iv) Write the names of all the members, which are accessible from objects of class SHOP



Ans Input (), Output ()

*(1 Mark for writing correct answer)*

**OR**

*(½ Mark for writing any one correct member function)*

3. (a) Write a function SWAP2BEST (int ARR[], int Size) in C++ to modify the content of the array in such a way that the elements, which are multiples of 10 swap with the value present in the very next position in the array. 3

For example:

If the content of array ARR is

90, 56, 45, 20, 34, 54

The content of array ARR should become

56, 90, 45, 34, 20, 54

Ans void SWAP2BEST(int ARR[], int Size)

```
{  
    int t;  
    for(int i=0;i<Size-1;i++)  
    {  
        if (ARR[i] %10=0)  
        {  
            t=ARR[i];  
            ARR[i]=ARR[i+1];  
            ARR[i+1]=t;  
            i++; //Ignore if not. written  
        }  
    }  
}
```

*(1/2 Mark for correct loop)*

*(1 Mark for checking array elements which are multiples of 10)*

*(1/2 Mark for swapping the element with value in the next position)*

**Note:**

*Marks not to be deducted for running the loop till  $i < \text{Size}$  instead of  $i < \text{Size}-1$*

*Marks not to be deducted for not incrementing  $i$  inside the body of the if construct*

- (b) An array T[20][10] is stored in the memory along the column with each of the elements occupying 2 bytes. Find out the memory location of T[10][5], if the element T[2][9] is stored at the location 7600.

3

Ans Assuming LBR=LBC=0

W=2 bytes

Number of Rows (M) =20

Number of Columns (N)=10

$\text{LOC}(T[I][J]) = B + (I + J*M) * W$

$\text{LOC}(T[2][9]) = B + (2+9*20) * 2$

$7600 = B + (182*2)$

$B = 7600 - 364$

$B = 7236$

$\text{LOC}(T[10][5]) = 7236 + (10+5*20) * 2$

$= 7236 + (110*2)$

$= 7236 + 220$

$= 7456$

**OR**

Assuming LBR=2, LBC=9 and B = 7600

W=2 bytes

Number of Rows (M) = 20

Number of Columns (N) = 10

$$\begin{aligned} \text{LOC (T[I] [J])} &= B + ((I-LBR) + (J-LBC)*M)*W \\ \text{LOC (S[10] [5])} &= 7600 + ((10-2) + (5-9)*20)*2 \\ &= 7600 + (8-80) * 2 \\ &= 7600 + (-72)) * 2 \\ &= 7600 - 144 \\ &= 7456 \end{aligned}$$

**OR**

Assuming LBR=LBC=1

W=2 bytes

Number of Rows (M) = 20

Number of Columns (N) = 10

$$\text{LOC (T[I] [J])} = B + ((I-LBR) + (J-LBC)*M)*W$$

$$\text{LOC (T[2] [9])} = B + ((2-1) + (9-1)*20) * 2$$

$$7600 = B + (161*2)$$

$$B = 7600 - 322$$

$$B = 7278$$

$$\text{LOC (T[10] [5])} = 7278 + ((10-1)+(5-1)*20) * 2$$

$$= 7278 + (9+80) *2)$$

$$= 7278 + 178$$

$$= 7456$$

***(1 Mark for writing correct formula (for column major) OR substituting formula with correct values for calculating Address)***

***(1 Mark for correct calculation)***

***(1 marks for writing correct address)***

**Note:**

- 1 Mark to be awarded for writing only the correct answer (i.e. 7456)

- 2 Marks to be awarded if the formula and/or substitution is correct and total number of rows is considered as 21
  - Do not deduct any marks, if the formula/substitution is represented in any other equivalent form
- (c) Write a function in C++ to perform Insert operation in a static circular Queue containing Book's information (represented with the help of any array of structure BOOK)

4

```
struct BOOK
{
    long Accno;           //Book Accession Number
    char Title [20]      //Book Title
};
```

```
Ans const int Max = 10;
void insert(Book B[], int &a, int F)
{
    if ( (R+1) %Max! =F)
    {
        R= (R+1) %Max;
        cin>>B [R] . Accno;
        //cin>>B[R] .Title OR cin.getline(B[R] .Title,20); OR
        gets(B[R] .Title) ;
    }
    else
        cout<<"Queue Full";
}
```

**OR**

```
const intmax =10;
```

```

void insert ( long newAC, char newTitle[], Book B [],int &F,int &R)
{
    if ( (F = 0 && R=max-1) || (F=R+1))
        cout<<"Queue Overflow";
    else
    {
        if (R == -1)
            F=0; R=0;
        else if (R == max-1)
            R = 0;
        else
            R = R + 1;
        B[R].Accno = newAC;//OR cin>>B[R].Accno;
        strcpy(B[R].Title, newTitle);
        // OR gets(B[R].Title); OR cin>>B[R].Title OR
        //cin.getline(B[R].Title,20) ;
    }
}

```

**OR**

**Any other equivalent correct answer acceptable**

*(1 Mark for writing function header correctly)*

*(1 Mark for checking if Queue is Full)*

*(1 Mark for incrementing Rear)*

*(1 Mark for assigning Values to the Rear location of the Queue)*

- (d) Write a function ALTERNATE (int A[ ][3], int N, int M) in C++ to display all alternate elements from two-dimensional array A (starting from A[0][0]).

1

For example:

If the array is containing:

23 54 76

37 19 28

62 13 19

The output will be

23 76 19 62 19

Ans. void ALTERNATE (int A [] [3], int N, int M)

```
{
int T=0;
for (int I=0 ; I<N; I++)
    for (int J=0 ; J<M ; J++)
    {
        if (T%2= =0)
            cout<<A[I] [J]<<" ";
        T++;
    }
}
```

OR

void ALTERNATE (int A[] [3], int N, int M)

```
{
    int *P=&A[0] [0] ;
    for (int I=0; I<N*M ; I+=2)
    {
        cout<<*p<<" ";
        P+=2 ;
    }
}
```

**OR**

**Any other equivalent correct answer acceptable**

*(1 Mark for writing Correct loops starting for location [0] [0])*

*(1/2 Mark for logic of checking alternate elements)*

*(1/2 Mark for displaying the alternate elements)*

- (e) Evaluate the following POSTFIX notation. Show status of Stack after every step of evaluation (i.e. after each operator):

2

True, False, NOT, AND, False, True, OR, AND

Ans	Element Scanned	Stack Status
	True	True
	False	True, False
	NOT	True, True
	AND	True
	False	True, False
	True	True, False, True
	OR	True, True
	AND	True

**Final Answer: True**

*(1/2 Mark for evaluating till NOT operator)*

*(1/2 Mark for evaluating till the next AND operator)*

*(1/2 Mark for evaluating till the next OR operator)*

*(1/2 Mark for evaluating till the last AND Operator and Final Answer)*

Note:

*(1 Mark for only writing the final answer as True without showing the Stack Status)*

- 4 (a) Observe the program segment given below carefully and the questions that follow:

1

```
class Stock
```

```

{
    int Ino, Qty ; char Item [20];
public:
    void Enter() {cin>>Ino;gets(Item) ; cin>>Qty;}
    void issue(int Q){Qty+=Q;}
    void Purchase(int Q){Q-=Q;}
    int GetIno () {return Ino;}
};

void PurchaseItem(int Pino,int PQty)
{
    ifstream File;
    File.open("STOCK.DAT", ios::binary|ios: :in|ios: :out);
    Stock S;
    int Success=0;
    while (Success==0 && File.read((char*)&S,sizeof(S)))
    {
        if (Pino==S. GetIno())
        {
            S.PurchaSe (PQ)      ;
            _____          // Statement 1
            _____          // Statement 2
            Success++;
        }
    }
}
}

if (Success=1)

```



```

        Cout<<"Purchase Updated"<<endl;
else
        Cout<<' 'Wrong Item No"<<endl;
File.close() ;

```

- (i) Write statement 1 to position the file pointer to the appropriate place so that the data updation is done for the required item.

Ans `File.seekp(File.tellg() - sizeof(Stock));`

OR

`File.seekp(-sizeof(Stock), ios::cur);`

*(1/2 Mark for writing Statement 1 correctly)*

**Note:**

*Seekp() and seekg() may be used interchangeably*

*tel/p() and tel/g() may be used interchangeably*

- (ii) Write statement 2 to perform the write operation so that the updation is done in the binary file.

Ans `File.write((char*)&S, sizeof(S));`

OR

`File.write((char*)&S, sizeof(Stock));`

*(1/2 Mark for writing any of the above statements)*

- (b) Write a function in C++ to read the content of a text file "DELHI.TXT" and display all those lines on screen, which are either starting with 'D' or starting with 'M'

2

Ans `void DispDorM()`

```

{
    ifstream File("DELHI.TXT");
    char Str[80];
    while(File.getline(Str, 80))

```

```

    {
        if(Str[0]='D' || Str[0]='M')
            cout<<Str<<endl;
    }
    File.close(); //Ignore
}

```

**OR**

**Any other correct function definition performing the desired operation**

*(1/2 Mark for opening DELHI. TXT correctly)*

*(1/2 Mark for reading each Line (Whichever method adopted) from the file)*

*(1/2 Mark for checking lines starting with 'D' or 'M' )*

*(1/2 Mark for displaying the lines)*

**NOTE:**

***Ignore case sensitivity while checking for 'D' or 'M'***

- (c) Write a function in C++ to search for the details (Phone no and Calls) of those Phones, which have more than 800 calls from a binary file "phones.dat" Assuming that this binary file contains records/objects of class Phone, which is defined below.

3

```

class Phone
{
    char Phoneno [10] ; int Calls ;
public:
    void Get () {gets (Phoneno) ; cin>>calls;}
    void Billing() {cout<<Phoneno<<"#"<<Calls<<endl;}
    int GetCalls () {return Calls;}
} ;

```

Ans void Search ( )

```

{

```

```

Phone P;
fstream fin;
fin.open ("phones.dat", ios::binary|ios::in);
while (fin.read((char*) &P, sizeof (P)))
{
    if(P.GetCalls () > 800)
        P.Billing () ;
}
fin.close () ; // Ignore
}

```

Ignore

**OR**

**Any other correct function definition performing the desired operation**

*(1/2 Mark for declaration of object using fstream/ifstream)*

*(1/2 Mark for opening phones.dat correctly)*

*(1/2 Mark for reading record(s) from phones.dat)*

*(1/2 Mark for correct formation of/oop)*

*(1/2 Mark for checking if value returned by GetCalls () > 800)*

*(1/2 Mark for displaying the matching record)*

**Note:**

**Marks not to be deducted for the comparison as  $\geq 800$**

- 5 (a) Give a suitable example of a table with sample data and illustrate Primary and Alternate Keys in it.

Ans A table may have more than one such attribute/group of attribute that Identifies a row/tuple uniquely, all such attribute(s) are known as Candidate Keys. Out of the Candidate keys, one is selected as Primary Key. while the rest are the Alternate Keys

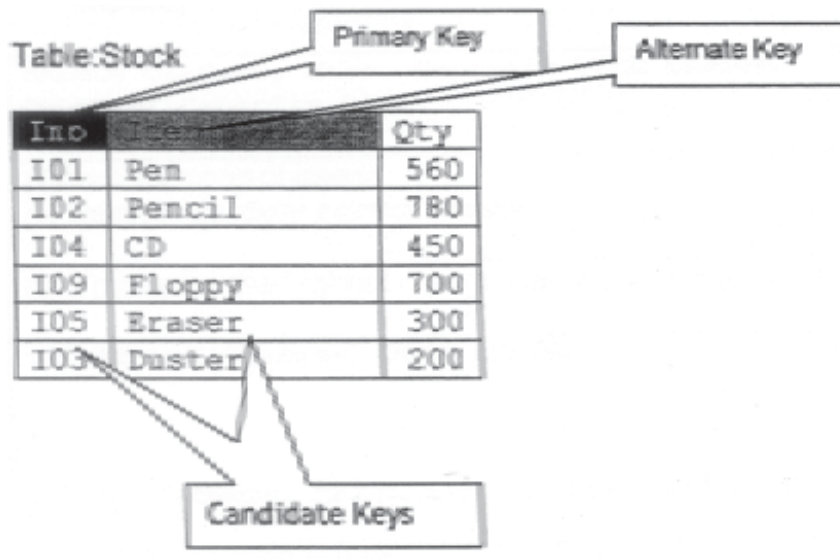

*(1 Mark for writing suitable example / correct definition of a table)*

*(1/2 Mark for correct illustration / definition of Primary Key)*

*(1/2 Mark for correct illustration / definition of Alternate Keys)*

Consider the following tables CARDEN and CUSTOMER and answer

(b) and (c) parts of this question:

**Table: CARDEN**

Ccode	CarName	Make	Color	Capacity	Charges
501	A-Star	Suzuki	RED	3	14
503	Indigo	Tata	SILVER	3	12
502	Innova	Tovota	WHITE	7	15
509	SX4	Suzuki	SILVER	4	14
510	C Class	Mercedes	RED	4	35

**Table: CUSTOMER**

CCode	Cname	Ccode
1001	Hemant Sahu	501
1002	Raj Lal	509
1003	Feroza Shah	503
1004	Ketan Dhal	502

(b) Write SQL commands for the following statements:

4

(i) To display the names of all silver colored Cars.

Ans SELECT CarName FROM CARDEN

WHERE Color = 'SILVER';

*(1 Mark for correct query)*

*(1/2 Mark for partially correct answer)*

(ii) To display name of car, make and capacity of cars in descending order of their sitting capacity.

Ans SELECT CarName, Make, Capacity FROM CARDEN

ORDER BY Capacity DESC;

*(1 Mark for correct query)*

*(1/2 Mark for partially correct answer)*

(iii) To display the highest charges at which a vehicle can be hired from CARDEN.

Ans SELECT MAX (Charges) FROM CARDEN ;

OR

SELECT CarName, MAX (Charges) FROM CARDEN GROUP BY CarName ;

*(1 Mark for correct query)*

*(1/2 Mark for partially correct answer)*

(iv) To display the customer name and the corresponding name of the cars hired by them.

Ans SELECT CName, CarName FROM CUSTOMER, CARDEN

WHERE CUSTOMER.Ccode = CARDEN.Ccode ;

OR

SELECT CUSTOMER. CName, CARDEN. CarName FROM CUSTOMER,  
CARDEN WHERE CUSTOMER.Ccode = CARDEN.Ccode ;

OR

SELECT CName, CarName FROM CUSTOMER A, CARDEN B  
WHERE A.Ccode = B.Ccode;

OR

SELECT A. CName, B. CarName FROM CUSTOMER A, CARDEN B  
WHERE A.Ccode = B.Ccode;

*(1 Mark for correct query)*

*(1/2 Mark for partially correct answer)*

(c) Give the output of the following SOL queries:

2

(i) SELECT COUNT (DISTINCT Make) FROM CARDEN;

Ans

COUNT (DISTINCT Make)
4

*(1/2 Mark for correct output)*

(ii) SELECT MAX (Charges), MIN (Charges) FROM CARDEN;

Ans

MAX (Charges)	MIN (Charges)
35	12

*(1/2 Mark for correct output)*

(iii) SELECT COUNT (\*), Make FROM CARDEN;

Ans (Ignoring Make for display)

COUNT (*)
5

**OR**

(assuming the presence of GROUP By Make)

COUNT(*)	Make
2	SUZUKJ:
1	TATA
1	TOYOTA
1	MERCEDES

OR

No Output

OR

Incorrect Syntax/Error/Query will not run

*(1/2 Mark for writing any of the above or any answer conveying same meaning)*

OR

*(1/2 Mark to be awarded if any two outputs out of (i), (jj) and (iv) are correct.*

(iv) SELECT CarName FROM CARDEN WHE~ Capacity = 4;

Ans

CarName
Sx4
CClass

*(1/2 Mark for correct output)*

6. (a) Verify the following using truth table:

2

(i)  $X, X' = 0$

Ans

X	X'	X . X'	0
0	1	0	0
1	0	0	0

↑  

Verified
----------

*(1 Mark for correct verification)*

OR

*(1/2 Mark for any two correct columns)*

(ii)  $X+1=1$

X	1	X +1
0	1	1
1	1	2

↑  

Verified
----------

(1 Mark for correct verification)

OR

(1/2 Mark for any two correct columns)

- (b) Write the equivalent Boolean expression for the following Logic Circuit:

2

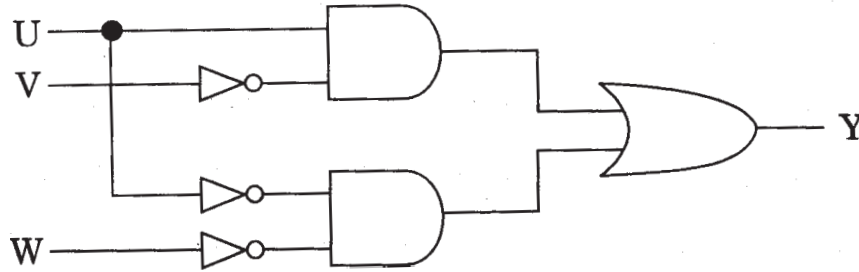

Ans.  $U \cdot V' + U' \cdot W'$

(2 Marks for the final expression  $U \cdot V' + U' \cdot W'$ )

OR

(1 Mark for any one of the correct terms out of  $U \cdot V'$  or  $U' \cdot W'$ )

- (c) Write the SOP form of a Boolean function  $F$ , which is represented in a truth table as follows:

X	Y	Z	F
0	0	0	1
0	0	1	0
0	1	0	1
0	1	1	0
1	0	0	1
1	0	1	0
1	1	0	0
1	1	1	1

Ans  $X'Y'Z' + X'YZ' + XY'Z' + XYZ$  OR  $F(X,Y,Z) = (0, 2, 4, 7)$

(1 Mark for the correct SOP form)

(1/2 mark for any two correct terms)

Note: Marks should not be deducted for any other variable names



(d) Reduce the following Boolean Expression using K-Map:

3

$$F(A, B, C, D) = (2, 3, 4, 5, 6, 7, 8, 10, 11)$$

Ans

	A'B'	A'B	AB	AB'
C'D'		1		1
C'D		1		
CD	1	1		1
CD'	1	1		1

**OR**

	C'D'	C'D	CD	CD'
A'B'			1	1
A'B	1	1	1	1
AB				
AB'	1		1	1

$$F(A, B, C, D) = A'B + A'C + B'C + AB'D'$$

*(1/2 Mark for placing all 1 s at correct positions in K-Map)*

*(1/2 Mark for each grouping)*

*(1/2 Mark for writing final expression in reduced/minimal form)*

**Note: marks should not be deducted for any other variable names**

7 (a) What out of the following, will you use to have an audio-visual chat with an expert sitting in a far-away place to fix-up a technical issue?

- (i) VoIP
- (ii) Email
- (iii) FTP

Ans (ii) VoIP

OR

None of the Options

*(1 Mark for writing correct option)*

(b) Name one server side scripting language and one client side scripting language. 1

Ans Client side scripts: Java script / VB script / Perl Tcl/Tk / REXX.

Server side scripts: JSP / ASP / PHP / CGI / Perl

*(½ Mark for writing one correct Client side scripting language name)*

*(½ Mark for writing one correct Server side scripting language name)*

(c) Which out of the following comes under Cyber Crime? 1

(i) Operating someone's Internet banking account, without his knowledge.

(ii) Stealing a keyboard from someone's computer.

(iii) Working on someone's computer with his/her permission.

Ans (i) Operating someone's Internet banking account, without his knowledge.

*(1 Mark for writing correct option)*

(d) Write one advantage of Bus Topology of network. Also, illustrate how 4 computers can be connected with each other using star topology of network. 2

Ans Cable length required for this topology is the least compared to other networks.

OR

Any other correct advantage of Bus Topology of network.

Illustration of 4 computers connected with each other using star topology of network.

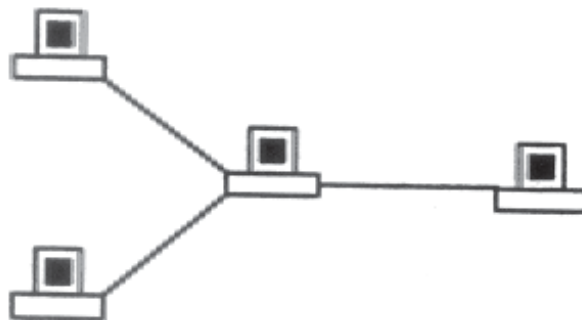

*(½ Mark for writing one correct advantage)*

*(½ Mark for drawing / writing correct illustration OR any other diagrammatic representation for star topology)*

- (e) Workalot Consultants are setting up a secured network for their office campus at Gurgaon for their day-to-day office and web-based activities. They are planning to have connectivity between 3 buildings and the head office situated in Mumbai Answer the questions (i) to (iv) after going through the building positions in the campus and other details, which are given below:

3

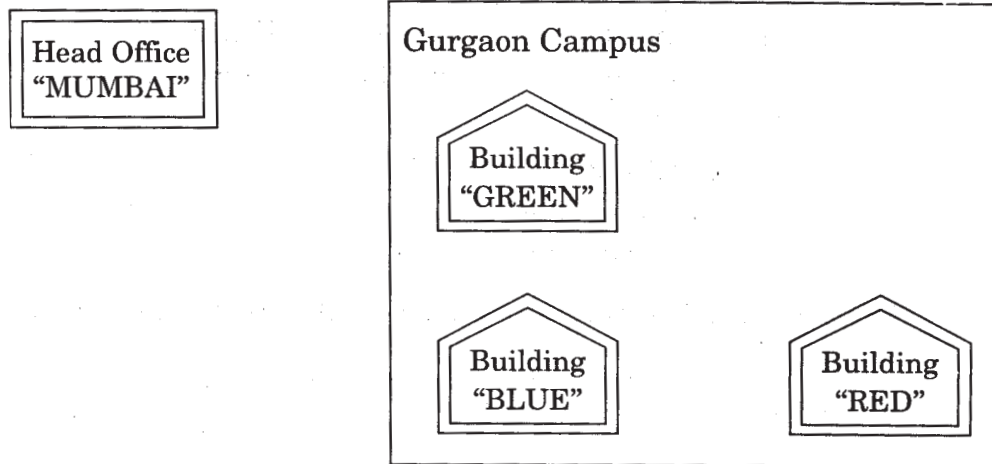

**Distances between various buildings**

Building "GREEN" to Building "RED"	110 m
Building "GREEN" to Building "BLUE"	45 m
Building "BLUE" to Building "RED"	65 m
Gurgaon Campus to Head Office	1760 KM

**Number of Computers**

Building "GREEN"	32
Building "RED"	150
Building "BLUE"	45
Head Office	10

- (i) Suggest the most suitable place (Le. building) to house the server of this organization. Also give a reason to justify your location.

Ans Building "RED", since it contains maximum number of computers

OR

Building "BLUE", since it is closest to "GREEN" and "RED"

*(½ Mark for writing any correct place)*

*(½ Mark for correct justification)*

- (ii) Suggest a cable layout of connections between the buildings inside the campus.

Ans Gurgaon Campus

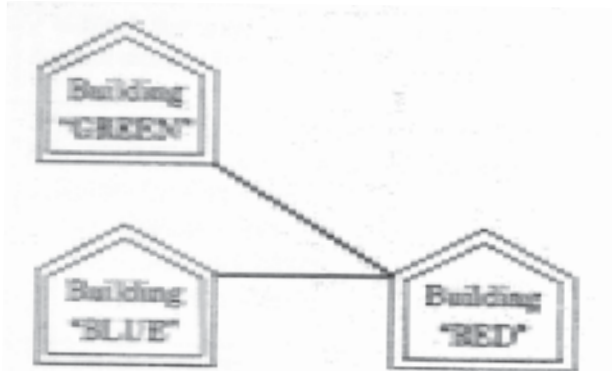

OR

Gurgaon Campus

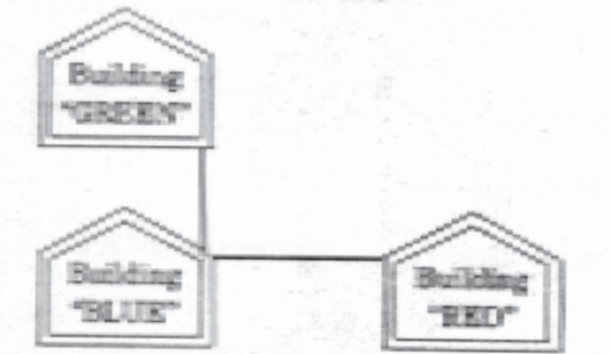

*(1 Mark for drawing /writing any valid connectivity or topology or diagram connecting various buildings inside the campus)*

**NOTE: Ignore placement/order of buildings in the diagrammatic representation**

- (iii) Suggest the placement of the following devices with justification:

- (1) Switch
- (2) Repeater

Ans (1) Switch:

In each of the buildings, since a network switch is a networking device that joins multiple computers together within one local area network (LAN).

(2) Repeater:

For the Layout 1 drawn in (e2)- Between buildings "GREEN" and "RED", since distance between these two buildings is greater than 70 m which will otherwise lead to loss of signal intensity for data to be transferred.

For the Layout 2 drawn in (e2): Repeater is not needed, since distance between both the buildings connected to "Ganga" is less than 70 m, not leading to any signal loss

OR

Any other placement of Repeater with proper justification

*(½ Mark for writing correct placement and/or justification of Switch)*

*(½ Mark for writing correct placement and/or justification of Repeater, according to layout drawn for e2)*

(iv) The organization is planning to provide a high speed link with its head office situated in the MUMBAI using a wired connection. Which of the following cable will be most suitable for this job?

- (i) Optical Fibre
- (ii) Co-axial Cable
- (iii) Ethernet Cable

Ans (i) Optical Fibre

*(1 Mark for writing correct option)*

(f) Give one suitable example of each URL and Domain Name

1

Ans URL Example: <http://www.w3schools.com/html/default.asp>

OR

[www.youtube.com](http://www.youtube.com)

Domain Name Example: w3schools.com

OR

Any other correct URL and Domain Name Examples

Note: Domain names in both the examples may/may not be same

*(½ Mark for writing any correct URL Example)*

*(½ Mark for writing any correct Domain Name Example)*

(g) Name two Proprietary softwares along with their application.

1

Ans Microsoft Office - For office applications

Adobe Photoshop - For design related works

Autocad - For professional Design

MAYA - For professional animations & Movie making

3D Studio - For 3 dimensional objects

Tally - For accounting

Oracle Database - For database management

*(½ mark each for any 2 of the above mentioned or any other proprietary software with/or without their application areas)*

# ENGINEERING GRAPHICS

*Time allowed : 3 hours*

*Maximum Marks : 70*

**Note :**

- (i) Attempt **all** the questions.
- (ii) Use both sides of the drawing sheet, if necessary.
- (iii) **All** dimensions are in millimetres.
- (iv) Missing and mismatching dimensions, if any, may be suitably assumed.
- (v) Follow the SP:46, 2003 revised codes. (with first angle method of projection)
- (vi) In no view of question 1 are hidden edges or lines required.
- (vii) In question 3, hidden edges or lines are to be shown in views without section.
- (viii) Number your answers according to questions.

## QUESTION PAPER CODE 68/1

1. (a) Construct an isometric scale, 85 mm long. 4
- (b) Draw an isometric projection of the frustum of a hexagonal pyramid with base edge 30 mm, top-edge 25 mm and height of the frustum 70 mm. One of the base edge is perpendicular to VP and the axis is perpendicular to HP. Give all the dimensions. 7
- (b) A cylinder of diameter 60 mm and height 70 mm is placed centrally on the top surface of a triangular prism with base edge 60 mm and height 20 mm. The common axis is perpendicular to HP. One of the base edge is parallel to VP and is nearer to VP. Draw the isometric projection of the solids placed together. Give all the dimensions. Show the common axis and the direction of viewing. 13
2. (a) Draw to scale 1 : 1, the standard profile of the metric thread (Internal) with pitch 40 mm. Give standard dimensions. 8

**OR**

Draw to scale 1 : 1 the front view and the top view of a T-head bolt size M20.  
Keep the axis perpendicular to HP. Give standard dimensions.

- (b) Sketch freehand the front view and top view of a cheese head screw of size M25. Keep the axis vertical. Give all the standard dimensions.

5

**OR**

Sketch freehand the front view, top view and side view of a rectangular sunk taper key for a shaft of 60 mm diameter. Give all the standard dimensions.

3. Figure 1 shows the details of the parts of the Protected Flange Coupling. Assemble these parts and draw to scale 1 : 1, the following views of the assembly:

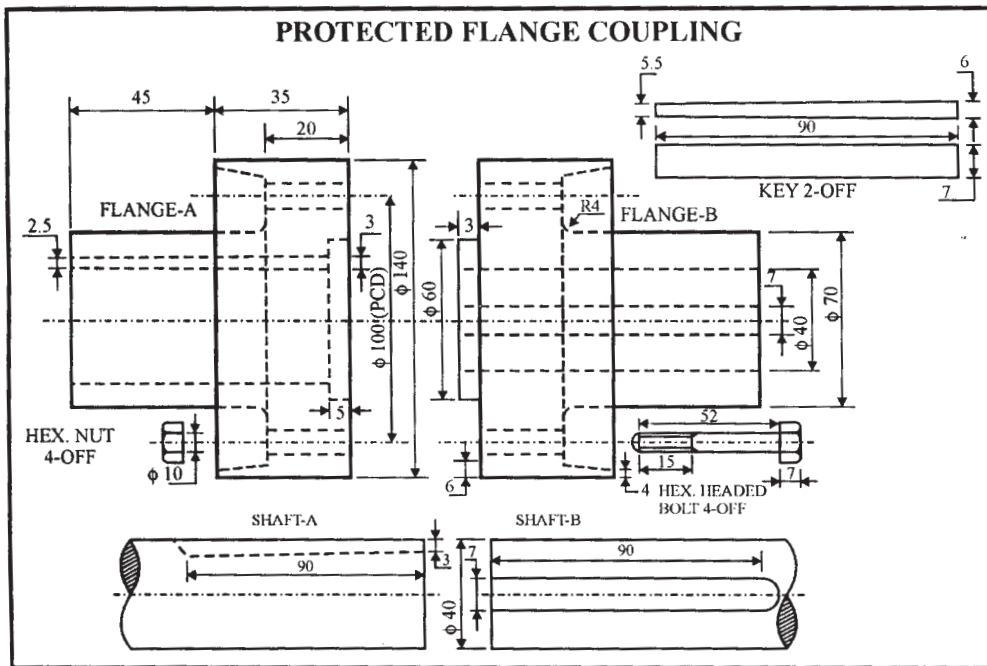

**Fig. 1**

- (a) Front view, upper half in section.

13

- (b) Side view as viewed from the left.

9

Print the heading and scale used. Draw the projection symbol. Give 6 important dimensions.

6

**OR**

Figure 2 shows the F.E. and the S.E. of the assembly of Bushed Bearing. Disassemble the parts and draw the views of the following parts to scale 1 : 1. Keep the same position of the parts w.r.t. HP and VP.



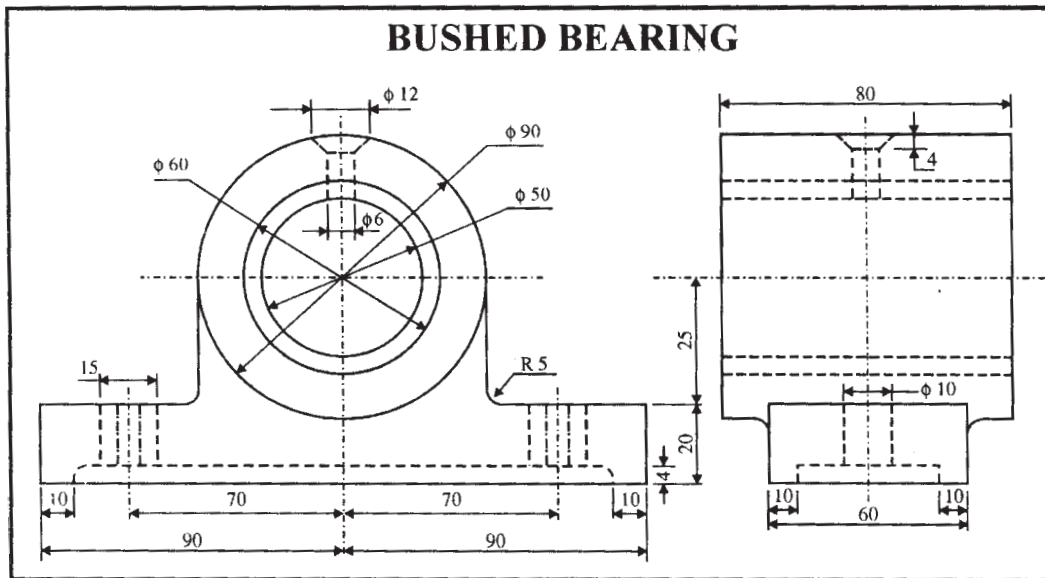

Fig. 2

(a) BODY

(i) Front view, right half in section

8

(ii) Top view

7

(b) BUSH

(i) Front view, left half in section

4

(ii) Top view

3

Print titles of both and scale used. Draw the projection symbol. Give 6 important dimensions.

6

4. Answer the following multiple choice questions. Print the correct choice on your drawing sheet.

5

(i) The angle that the body diagonal of a cube makes with the plane of projection in its true isometric projection is :

(a)  $60^\circ$

(b)  $30^\circ$

(c)  $90^\circ$

(d)  $120^\circ$

- (ii) A square in isometric projection appears as :
  - (a) Square
  - (b) Rhombus
  - (c) Rectangle
  - (d) Trapezium
- (iii) In first angle projection the order of object, plane and observer, as viewed from the front is
  - (a) object, plane and observer
  - (b) object, observer and plane
  - (c) plane, observer, object
  - (d) observer, object, plane
- (iv) Crowning in a C.I. pulley is provided to :
  - (a) correct tension of belt
  - (b) prevent slipping of the belt
  - (c) strengthen the rim
  - (d) help in casting
- (v) A rubber ring as a gasket in Flange coupling is provided to
  - (a) check leakage of fluid in pressure in pipes
  - (b) align the two flanges
  - (c) to fill the gap between the flanges
  - (d) to support the nuts and bolts.

## QUESTION PAPER CODE 68

1. (a) Construct an isometric scale, 95 mm long. 4
- (b) Draw an isometric projection of the frustum of an equilateral triangular pyramid with base edge 50 mm, top edge 40 mm and height 70 mm. It is resting on HP with one of the base edges on HP and nearer to VP. The axis is perpendicular to HP. Give all the dimensions. 7
- (c) A cylinder of diameter 50 mm and height 60 mm is placed centrally on the top surface of a pentagonal prism (base edge 40 mm and height 25 mm). The common axis is perpendicular to HP. One of the base edges of the prism is parallel to VP and is nearer to the observer. Draw the isometric projection of the solids placed together. Show the common axis and the direction of viewing. Give all dimensions. 13
2. (a) Draw to scale 1 : 1 the standard profile of a metric screw thread (external). Take pitch 40 mm. Give standard dimensions. 8

**OR**

Draw to scale 1 : 1 the front view and the top view of a Hook Bolt of size M20. Keep the axis perpendicular to HP. Give standard dimensions.

- (b) Sketch free hand the front view and top view of a Snap head rivet of diameter 25 mm. Keep the axis vertical. Give all the standard dimensions. 5

**OR**

Sketch free hand the front view and the top view of collar stud of size M25. Keep the axis vertical. Give all the standard dimensions.

3. Figure 1 shows the details of the parts of a Flanged Pipe Joint. Assemble these parts and draw to scale 1 : 1, the following views of the assembly:
- (a) Front view, upper half in section. 14
- (b) Side view as viewed from the right. 8
- Print the heading and scale used. Draw the projection symbol. Give 6 important dimensions. 6

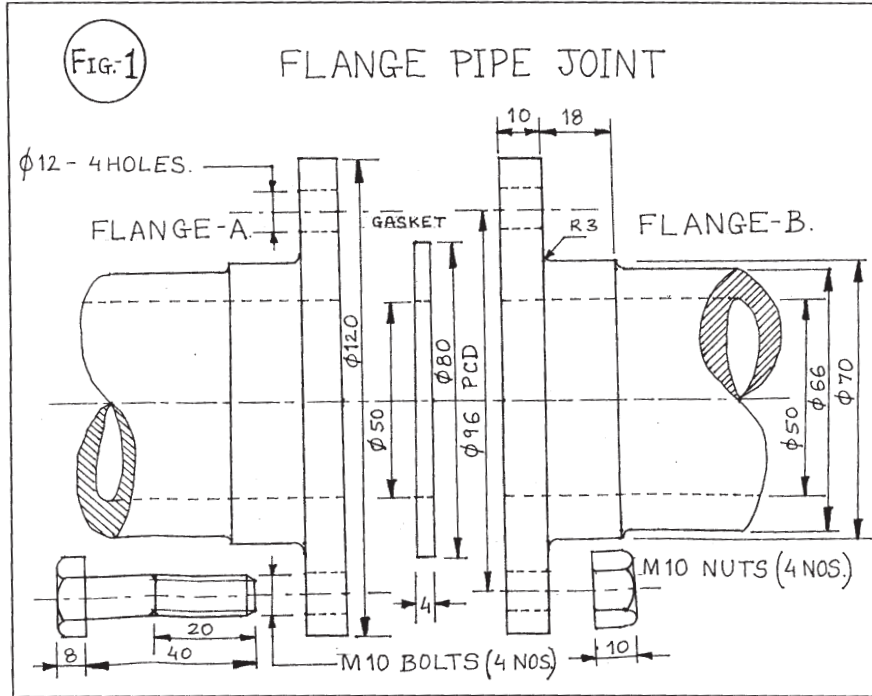

OR

Figure 2 shows the Front Elevation of the assembled Sleeve and Cotter Joint. Keeping the same position of the parts w.r.t. HP and VP, disassemble the parts and draw the following views to a scale 1 : 1 of the parts as stated:

- Front view of the sleeve, upper half in section and the side view as seen from left.
- Front view of the rod-A and side view as seen from right.

12

10

Print titles of both and scale used. Draw the projection symbol. Give 6 important dimensions.

6

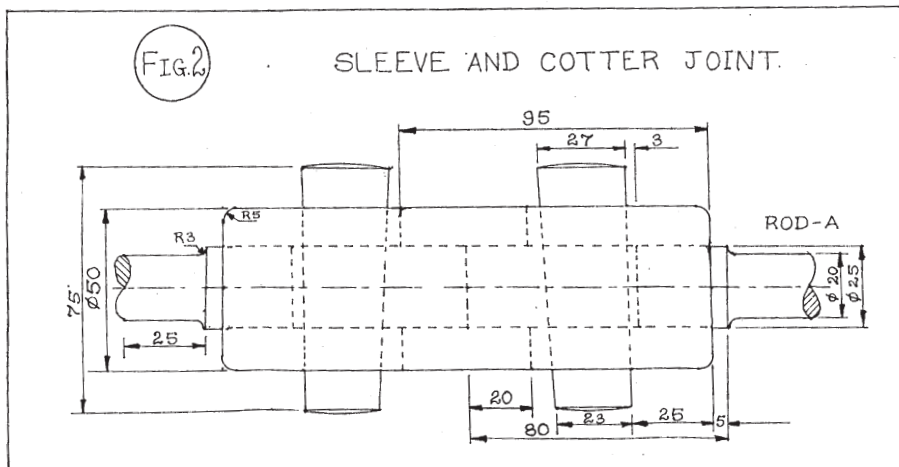

4. Answer the following Multiple Choice Questions. Print correct choice on your drawing sheet.

5

- (i) The three isometric axes are inclined to each other at
  - (a)  $60^\circ$
  - (b)  $120^\circ$
  - (c)  $30^\circ$
  - (d)  $90^\circ$
  
- (ii) The angle between the flanks of a BSW thread profile. is
  - (a)  $60^\circ$
  - (b)  $90^\circ$
  - (c)  $55^\circ$
  - (d)  $75^\circ$
  
- (iii) Number of clearances provided in Cotter Joint for square rods is
  - (a) 1
  - (b) 2
  - (c) 4
  - (d) 3
  
- (iv) Chamfering surface on a Nut and Bolt head has shape of
  - (a) Cone
  - (b) Triangular Pyramid
  - (c) Cylinder
  - (d) Triangular Prism
  
- (v) A machine part not sectioned is
  - (a) Bush
  - (b) Body/Base
  - (c) Snug
  - (d) Rivet

## Marking Scheme — Engineering Graphics

**All Questions are to be answered correctly and accurately.**

**General Note:**

- (i) Marks are to be awarded in proportion to the work done.
- (ii) Mistakes in dimensioning up to  $\pm 1.0$  mm may be ignored.
- (iii) In dimensioning, arrow-heads of various types, as per SP : 46-2003 codes, are usable. However, where space is too small for an arrowhead, oblique stroke or a dot may be employed.
- (iv) In no view of question 1 and in no sectioned view of question 3, are hidden edges/lines required.
- (v) Other standard methods of drawing/proportions for features like nuts, heads of bolts, screws etc., employed by examinees, may also be accepted.

### QUESTION PAPER CODE 68/1

S.No.	VALUE POINTS	Distribution of Marks
<b>Q 1 (a): ISOMETRIC SCALE</b>		<b>4</b>
(i)	Marking of divisions of 10 mm, 1 mm on true scale and marking angles of $30^\circ$ & $45^\circ$ .	1
(ii)	Projections from scale 1:1 to get points on isometric scale, Printing 'Scale 1:1' and 'Isometric Scale'.	1
(iii)	Construction of isometric scale, 85 mm long, with main divisions of 10 mm each.	1
(iv)	Division of the first part of isometric scale into 10 subdivisions.	1
<b>NOTE:</b>		
<i>½ mark is to be deducted in case an examinee constructs the scale for a length less than 80 mm.</i>		
<b>Q 1 (b): ISOMETRIC PROJECTION OF A FRUSTUM OF HEXAGONAL PYRAMID</b>		<b>7</b>

- |       |                                                                                                                   |    |
|-------|-------------------------------------------------------------------------------------------------------------------|----|
| (i)   | Helping figure (using either isometric scale, or 1: 1 scale) of both hexagons with one side perpendicular to V.P. | 1½ |
| (ii)  | Drawing isometric hexagons, on top and at the base.                                                               | 2½ |
| (iii) | Drawing slant edges.                                                                                              | 2  |
| (iv)  | Dimensioning                                                                                                      | 1  |

**NOTE:**

*For incorrect position of frustum, like keeping its axis perpendicular to V. P. in place of H. P. as asked, 2 marks should be deducted. Also in helping figure, if a side of the base is taken parallel to V.P., 1/2 mark should be deducted.*

**Q 1 (c): ISOMETRIC PROJECTION OF CYLINDER, PLACED CENTRALLY, ON AN EQUILATERAL TRIANGULAR PRISM** **13**

EQUILATERAL TRIANGULAR PRISM **6**

- |       |                                                                            |   |
|-------|----------------------------------------------------------------------------|---|
| (i)   | Helping figure of a triangle, with a base edge parallel and nearer to V.P. | 1 |
| (ii)  | Drawing isometric triangles.                                               | 2 |
| (iii) | Drawing face edges, parallel to vertical axis.                             | 2 |
| (iv)  | Dimensioning.                                                              | 1 |

CYLINDER **7**

- |       |                                                                                                             |   |
|-------|-------------------------------------------------------------------------------------------------------------|---|
| (i)   | Drawing isometric ellipses (2 for top and 1 for bottom) along with their center lines.                      | 3 |
| (ii)  | Drawing two generators (vertical edges), tangential to ellipses, ensuring central location of the cylinder. | 2 |
| (iii) | Common vertical axis and direction of viewing.                                                              | 1 |
| (iv)  | Dimensioning.                                                                                               | 1 |

**NOTE:**

*For incorrectly placed solids, deductions, as proposed in Q 1 (b), may be used.*

**Q 2 (a): METRIC SCREW THREAD PROFILE (INTERNAL)** **8**

- |     |                                                                                |    |
|-----|--------------------------------------------------------------------------------|----|
| (i) | Distance, equal to pitch, marked correctly and angles of 60°, drawn correctly. | 1½ |
|-----|--------------------------------------------------------------------------------|----|

- |       |                                                                 |    |
|-------|-----------------------------------------------------------------|----|
| (ii)  | Flat edges and curves for threads (minimum 2), drawn correctly. | 2½ |
| (iii) | Side edges (flanks), drawn correctly.                           | 1  |
| (iv)  | Dimensioning and hatching.                                      | 2  |
| (v)   | Line work and neatness.                                         | 1  |

**[OR]**

**T -HEAD BOLT** **8**

**FRONT VIEW**

- |      |                                                                                     |   |
|------|-------------------------------------------------------------------------------------|---|
| (i)  | Threaded and unthreaded portions of cylindrical shank, square neck and center line. | 3 |
| (ii) | Head of bolt.                                                                       | 1 |

**TOP VIEW**

- |      |                                                              |   |
|------|--------------------------------------------------------------|---|
| (i)  | Circles of diameter 'd' (thick) and '0.85d' (thin & broken). | 1 |
| (ii) | Square neck and the rest of the portion.                     | 1 |

Dimensioning, Neatness and Line work 2

**NOTE:**

*3 marks may be deducted, in all, if sketched freehand, instead of drawing to scale 1:1.*

**Q 2 (b): FREE HAND SKETCHING**

**CHEESE - HEAD SCREW (Size M25)** **5**

- |       |                                               |    |
|-------|-----------------------------------------------|----|
| (i)   | Front view with its axis perpendicular to HP. | 2½ |
| (ii)  | Top view.                                     | 1½ |
| (iii) | Dimensioning.                                 | 1  |

**[OR]**

**RECTANGULAR SUNK TAPER KEY (for a shaft of diameter 'd' = 60mm)** **5**

- |      |             |    |
|------|-------------|----|
| (i)  | Front view. | 1½ |
| (ii) | Side view.  | 1½ |



- (iii) Top view. 1
- (iv) Dimensioning. 1

(L= Any length::: 50 mm or more, W=d/4, T =d/6 and Taper of 1: 1 00)

**NOTE:**

*2 marks may be deducted, if these components are drawn with instruments, instead of being sketched freehand.*

**Q 3. PROTECTED FLANGE COUPLING (Assembly) 28**

(a) FRONT VIEW (Upper Half in Section) : 13

- (i) Upper, sectioned half of flanges, including socket and spigot arrangement, hole and hatching lines in opposite directions. 5
- (ii) Lower, unsectioned, half of flanges, including center line for bolt. 2
- (iii) Head of bolt, threaded and other portions of bolt and hexagonal nut. 2
- (iv) Shafts with hatching lines. 2
- (v) Keys and keyways. 2

(b) SIDE VIEW (viewed from left) : 9

- (i) 7 circles and hatching lines 4½
- (ii) Keys and keyways. 2
- (iii) Hexagonal nut and bolt. 2
- (iv) Cutting plane ½

DETAILS: 6

Titles (2), scale used (1), projection symbol (1) and 6 important dimensions (2).

**[OR]**

**BUSHED BEARING (Dis-assembly) 28**

(A) BODY 15

(a) FRONT VIEW (Right Half in Section) : 8

- (i) Marking boundary of body alongwith radii R5 at two locations, quarter circle of diameter = 90mm and the two axes. 2½

(ii)	Indicating center distance of two holes and clearance gap of 4mm at the base with. proper fillet.	1½
(iii)	Marking of hole of 15mm size.	1
(iv)	Marking of circle of diameter, 60mm.	1
(v)	Marking of oil hole.	1
(vi)	Hatching lines.	1
(b)	<u>TOP VIEW</u>	7
(i)	Drawing inner rectangle and side rectangles (thick) correctly.	2
(ii)	Drawing of bolt holes (1½), oil hole circles (1), two main center lines and all hidden lines (2).	4½
(iii)	Drawing cutting plane.	½
(B)	BUSH	7
(a)	<u>FRONT VIEW</u> (Left Half in Section) :	4
(i)	Darwing two circles with center lines.	2½
(ii)	Showing oil hole and hatching lines.	1½
(b)	<u>TOP VIEW</u>	3
(i)	Drawing rectangle, including hidden lines with center lines	1½
(ii)	Drawing oil hole circle.	1
(iii)	Drawing cutting plane.	½
	DETAILS:	6
	Titles (2), scale used (1), projection symbol (1) and 6 important dimensions (2).	

**NOTE:**

- 1) *As the views of the Bushed Bearing are drawn disproportionately, if any examinee has altered any of the diameters of the three circles, or any other dimension, while retaining the correctness of the answer, no marks should be deducted.*

2) In Protected Flange coupling if hatching of broken ends of both rods is shown as per question paper, no marks should be deducted.

**Q4: MULTIPLE CHOICE QUESTIONS**

**5**

- (i) (c) or  $90^\circ$  1
- (ii) (b) or Rhombus 1
- (iii) (d) or Observer, Object, Plane 1
- (iv) (b) or prevent slipping of the belt 1
- (v) (a) or check leakage of fluid in pipes 1

1(a)

Paper Code : 68/1

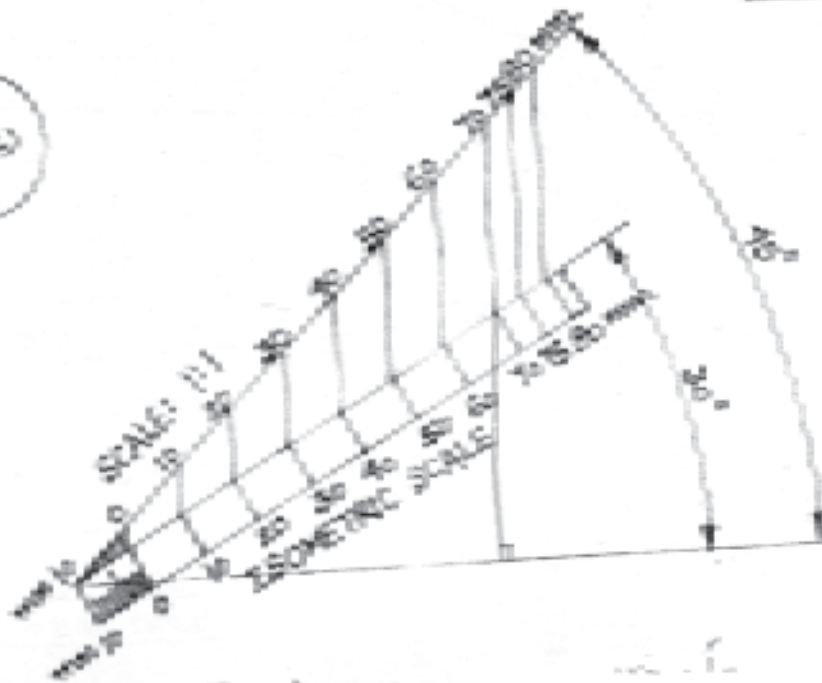

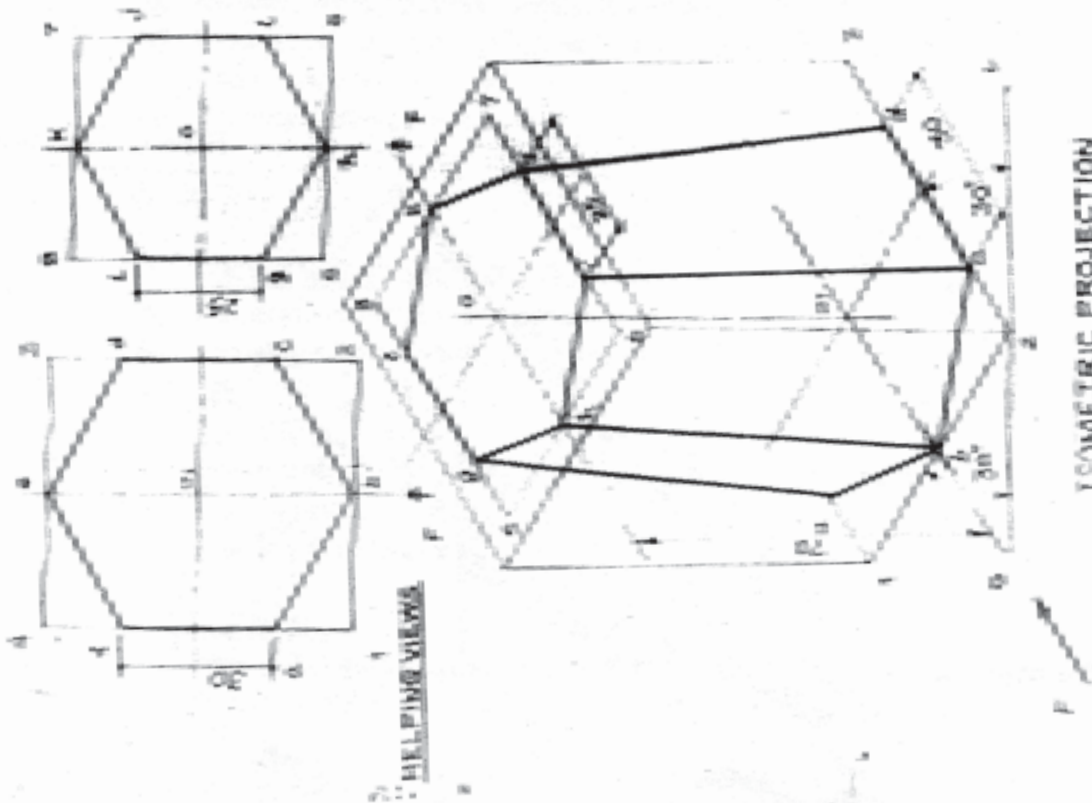
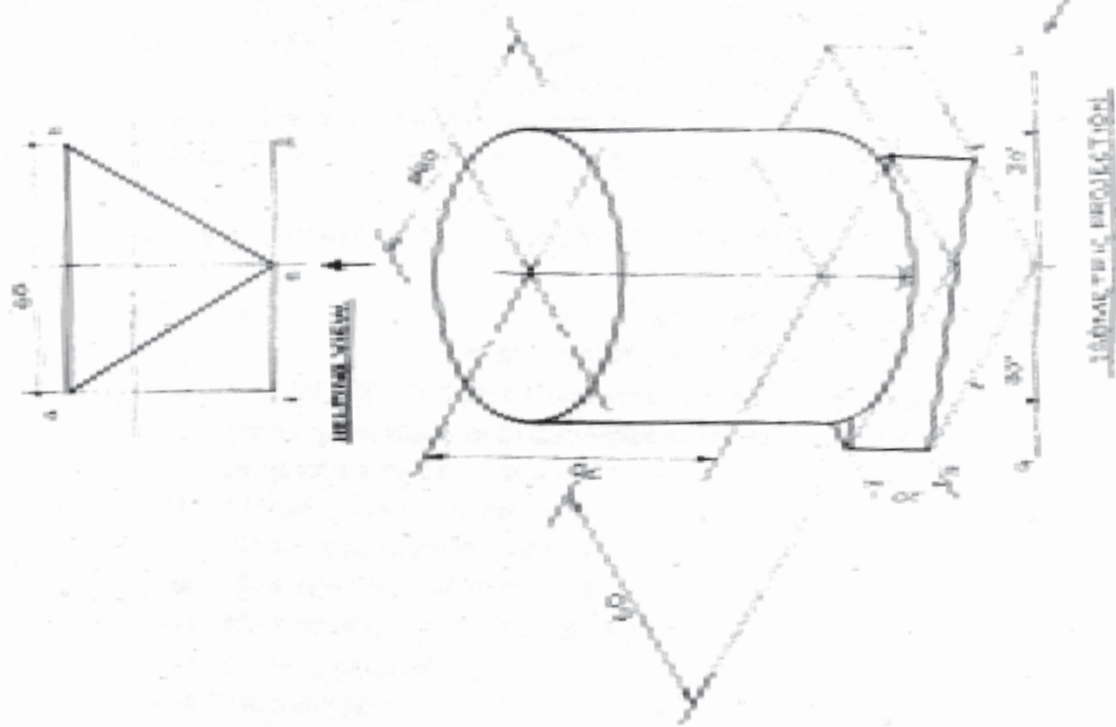

Q.2(b)

Code: 68/1

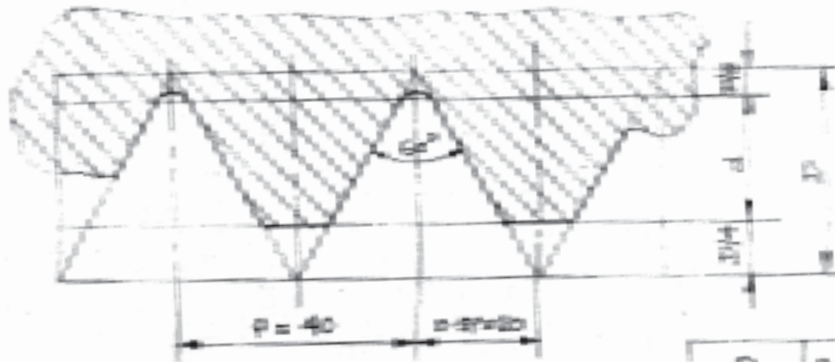

METRIC THREAD (INTERNAL)

P	$0.5P$	$\frac{3}{4}P$	d
40	20	$0.5 \times 40$	$0.5 \times 40$

Code: 68/1

Q.2(c)

d	25
$0.5d$	12.5
$0.75d$	18.75
$0.8d$	20
$0.85d$	21.25

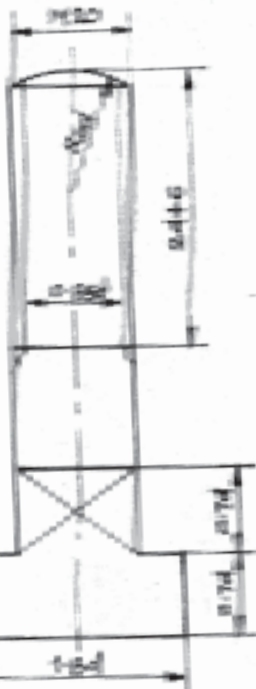

FRONT VIEW



TOP VIEW  
T-HEAD BOLT

Q.2(d)

Taper 1:100

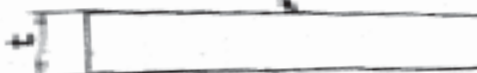

FRONT VIEW



SIDE VIEW

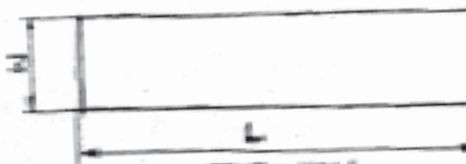

TOP VIEW

RECTANGULAR SHAFT  
TAPER KEY

Q.2(e)

$\phi d$	25
$0.25d$	6.25
$0.5d$	12.5
$1.5d$	37.5
$0.6d$	15

CHEESE HEAD SCREW

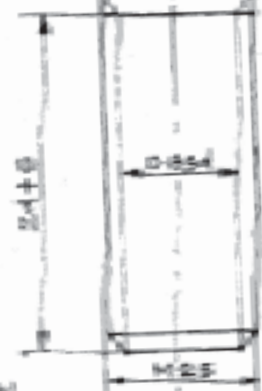
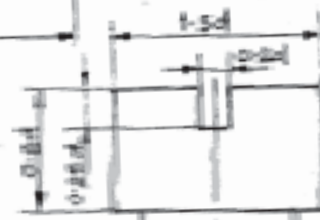

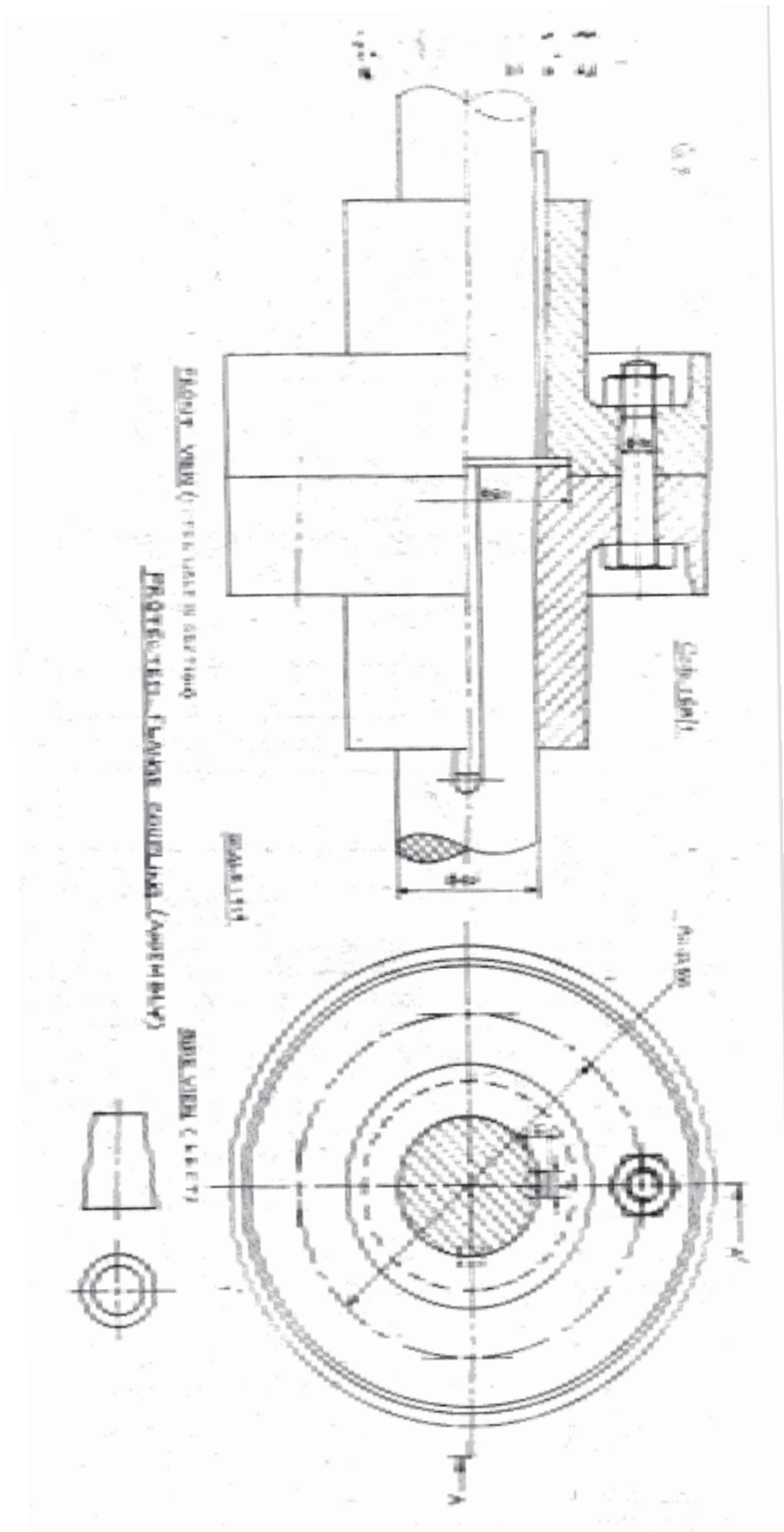

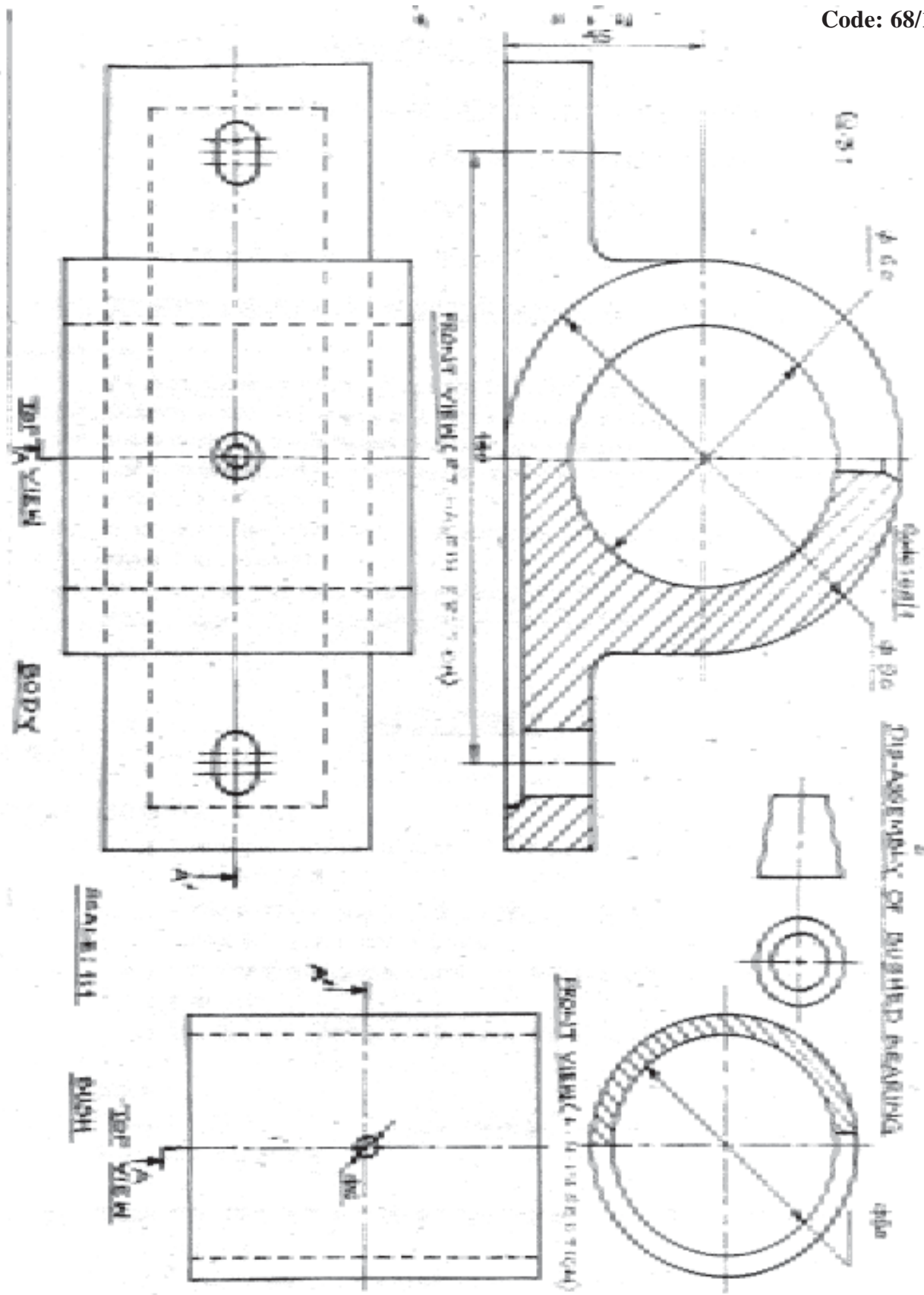

QUESTION PAPER CODE 68

S.No.	VALUE POINTS	Distribution of Marks
<b>Q 1 (a): ISOMETRIC SCALE</b>		<b>4</b>
(i) Marking of divisions of 10 mm, 1 mm on true scale and marking angles of 30° & 45°.		1
(ii) Projections from scale 1:1 to get points on isometric scale. Printing 'Scale 1:1' and 'Isometric Scale'.		1
(iii) Construction of isometric scale, 95 mm long, with main divisions of 10 mm each.		1
(iv) Division of the first part of isometric scale into 10 subdivisions.		1
<b>NOTE:</b>		
<i>½ mark is to be deducted in case an examinee constructs the scale for a length less than 90 mm.</i>		
<b>Q 1 (b): ISOMETRIC PROJECTION OF A FRUSTUM OF TRIANGULAR PYRAMID</b>		<b>7</b>
(i) Helping figure.		2
(ii) Drawing isometric triangles.		3
(iii) Drawing slant edges.		1
(iv) Dimensioning		1
<b>NOTE:</b>		
As the Q 1 (b)) does not provide clear information about the position of the base edges of the frustum w.r.t the V P , the examinees are free to take a base edge parallel to V.P. (nearer or farther from it), perpendicular to V P or at any other angle with VP		
<b>Q 1 (c): ISOMETRIC PROJECTION OF CYLINDER, PLACED CENTRALLY, ON A PENTAGONAL PRISM</b>		<b>13</b>
<u>PENTAGONAL PRISM</u>		<b>6</b>
(i) Helping figure.		1



(ii)	Drawing isometric pentagons.	3
(iii)	Drawing vertical edges.	1
(iv)	Dimensioning.	1
	<b><u>CYLINDER</u></b>	<b>7</b>
(i)	Drawing isometric ellipses (2 for top and 1 for bottom) along with their center lines.	3
(ii)	Drawing two generators (vertical edges), tangential to ellipses, ensuring central location of the cylinder.	2
(iii)	Common vertical axis and direction of viewing.	1
(iv)	Dimensioning.	1

**NOTE:**

*For incorrect position of solids, like keeping their common axis perpendicular to VP. in place of HP., as asked, 3 marks should be deducted. Also in helping figure, if a side of the base is taken perpendicular to VP., ½ mark should be deducted.*

<b>Q 2 (a):</b>	<b>METRIC SCREW THREAD PROFILE (EXTERNAL)</b>	<b>8</b>
(i)	Distance, equal to pitch, marked correctly and angles of 60°, drawn correctly.	1½
(ii)	Flat edges and curves for threads (minimum 2), drawn correctly.	2½
(iii)	Side edges (flanks), drawn correctly.	1
(iv)	Dimensioning and hatching.	2
(v)	Line work and neatness.	1

**[OR]**

<b>HOOK BOLT (Size M20)</b>	<b>8</b>
-----------------------------	----------

**FRONT VIEW**

(i)	Threaded and unthreaded portions of cylindrical shank, square neck and center line.	3
(ii)	Head of bolt.	1

TOP VIEW

- |      |                                                             |   |
|------|-------------------------------------------------------------|---|
| (i)  | Circles of diameter 'd' (thick) and '0.85d' (thin & broken) | 1 |
| (ii) | Square neck and the rest of the portion                     | 1 |
|      | Dimensioning, Neatness and Line work                        | 2 |

**NOTE:**

*3 marks may be deducted, In all, if sketched freehand, Instead of drawing to scale 1 I*

**Q 2 (b): FREE HAND SKETCHING**

**SNAP HEAD RIVET (Size M25) 5**

- |       |                                                |    |
|-------|------------------------------------------------|----|
| (i)   | Front view with its axis perpendicular to H.P. | 2½ |
| (ii)  | Top view.                                      | 1½ |
| (iii) | Dimensioning.                                  | 1  |

**[OR]**

**COLLAR STUD (Size M25) 5**

- |       |                                                |    |
|-------|------------------------------------------------|----|
| (i)   | Front view with its axis perpendicular to H.P. | 2½ |
| (ii)  | Top view.                                      | 1½ |
| (iii) | Dimensioning.                                  | 1  |

**NOTE:**

*2 marks may be deducted, if these components are drawn with instruments, instead of being sketched freehand.*

**Q 3 : FLANGED PIPE JOINT (Assembly) 28**

- |       |                                                                                                                                     |           |
|-------|-------------------------------------------------------------------------------------------------------------------------------------|-----------|
| (a)   | FRONT VIEW (Upper Half in Section) .                                                                                                | <b>14</b> |
| (i)   | Drawing both flanges and pipes in top half portion, including fillets of R3 and hatching in the broken end of pipe.                 | 3½        |
| (ii)  | Drawing both flanges and pipes in bottom half portion (without section), including fillets of R3 and hatching in broken end of pipe | 3½        |
| (iii) | Drawing a hole of $\phi 12$ on a p.c.d. of $\phi 96$ and hatching of flanges.                                                       | 2         |

(iv) Drawing bolts and nuts of M10 correctly (at one location at least).	4
(v) Indicating gasket in the upper half and lower half, and shading or cross-hatching in the upper half.	1
(b) <u>SIDE VIEW</u> (viewed from right) :	<b>8</b>
(i) Drawing 5 circles and pitch circle for bolts.	3
(ii) Drawing hatching lines to indicate pipe thickness.	2
(iii) Drawing chamfer circle, hexagon, $\phi 12$ hidden circle, M 10 circle (thick) and $\phi 0.85d$ circle (thin & broken) for nuts and bolts on p.c.d. (at one location at least)	2½
(iv) Drawing cutting plane	½
<b>DETAILS.</b>	<b>6</b>
Titles (2), scale used (1), projection symbol (1) and 6 Important dimensions (2)	

**[OR]**

<b>SLEEVE AND COTTER JOINT (Dis-assembly)</b>	<b>28</b>
(A) SLEEVE	<b>12</b>
(a) <u>FRONT VIEW</u> (Upper Half in Section) :	<b>8</b>
(i) Drawing upper half in section, including cotter holes (4), curves of R5 (1) and hatching lines (1).	6
(ii) Drawing lower half, center line and curves of R5.	2
(b) <u>SIDE VIEW</u> (viewed from right) :	<b>4</b>
Two circles of $\phi 50$ and $\phi 25$ (2) and hidden lines for cotter holes (2)	
(B) ROD - A	<b>10</b>
(a) <u>FRONT VIEW</u> (Left Half in Section) :	<b>6</b>
Cylindrical portion of diameter 25 and length 80 (2), cotter hole (2), cylindrical portion of diameter 20 and curves of R3 (2)	
(b) <u>SIDE VIEW</u> (viewed from right) :	<b>4</b>
Two circles (2), cotter hole lines and hatching lines (2)	

(C) DETAILS	<b>6</b>
Titles (2), scale used (1), projection symbol (1) and 6 important dimensions (2).	
Q4: MULTIPLE CHOICE QUESTIONS	5
(i) (b) or 120°	1
(ii) (c) or 55°	1
(iii)	1
Lack clarity and hence do not have single' and definite answers.	
(iv) Under the circumstances, all examinees, who have attempted these questions, must be awarded full marks.	1
(v) (d) or Rivet	1

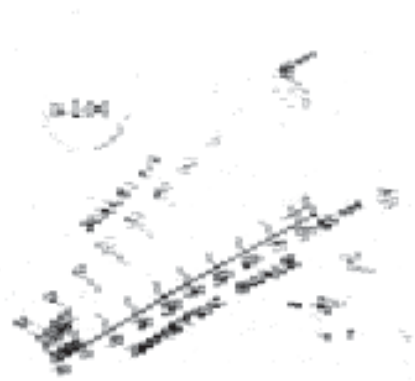

VIEW

Q100:

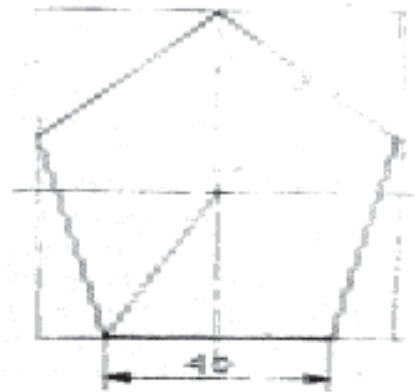

HELPING VIEW

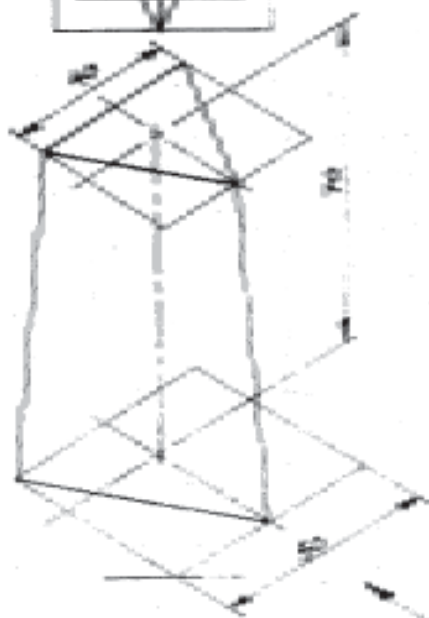
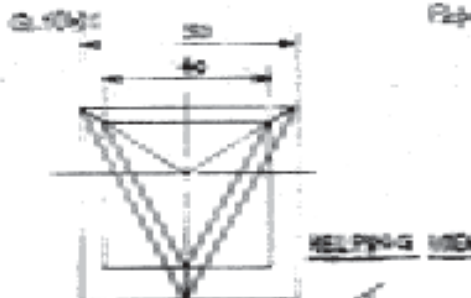

ISOMETRIC PROJECTION

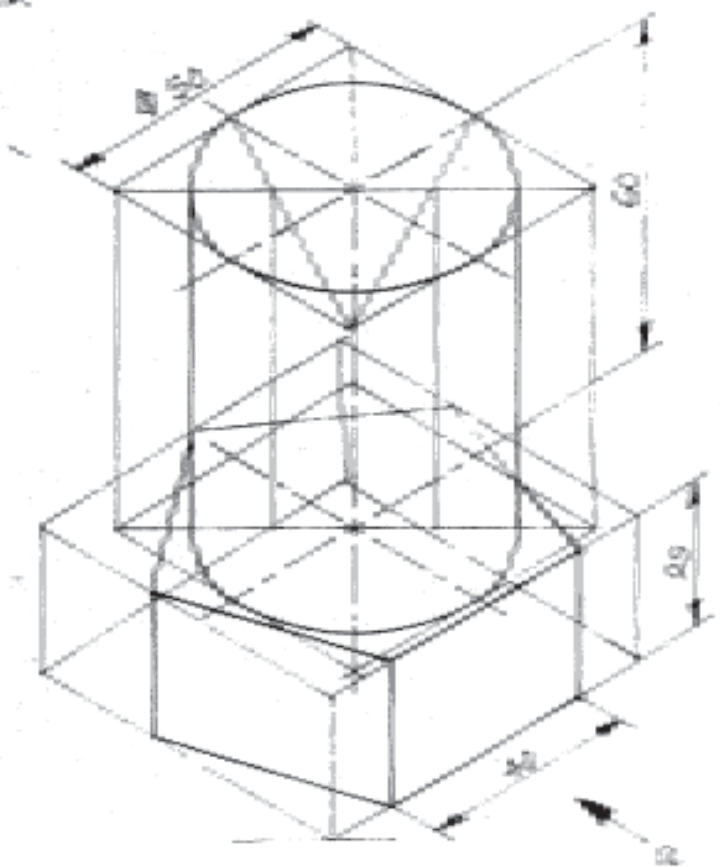

ISOMETRIC PROJECTION

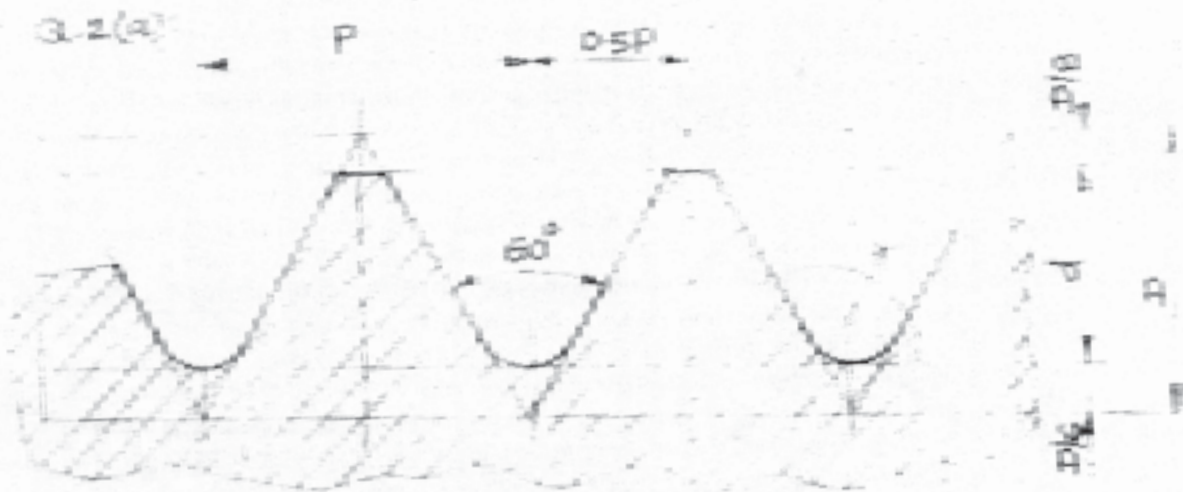

METRIC SCREW THREAD (EXTERNAL)

P	0.5P	D	d
40	20	0.66P	0.61P

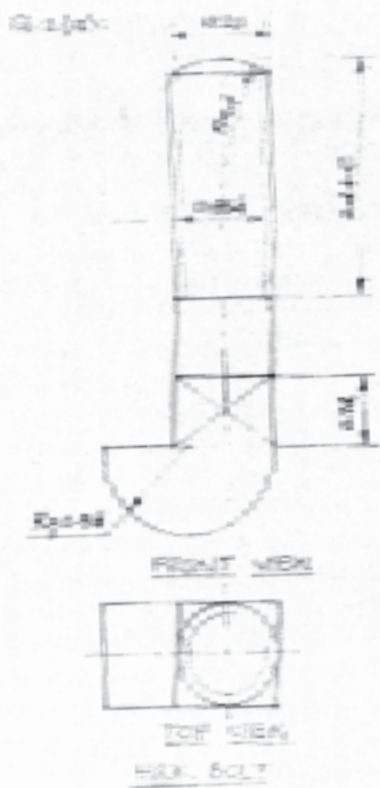

D	d	L	Chamfer	Chamfer
16	14	60	1.5	1.5

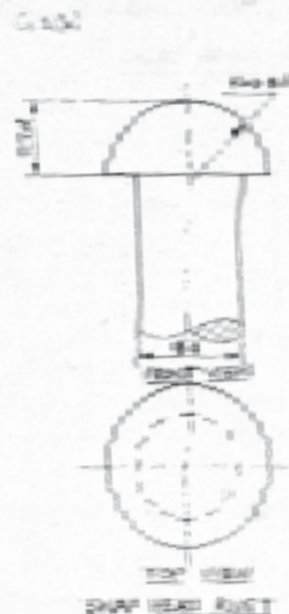

D	d	Chamfer	Chamfer
16	14	1.5	1.5

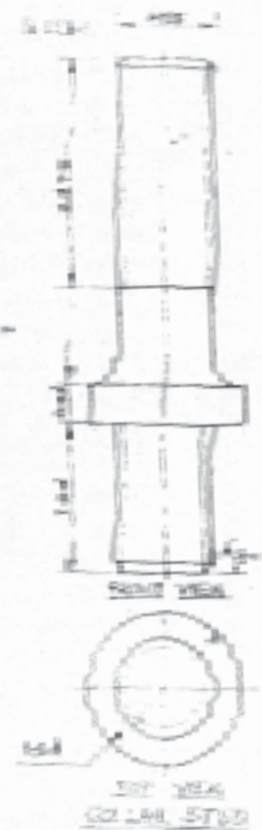

D	d	L	Chamfer	Chamfer
16	14	60	1.5	1.5

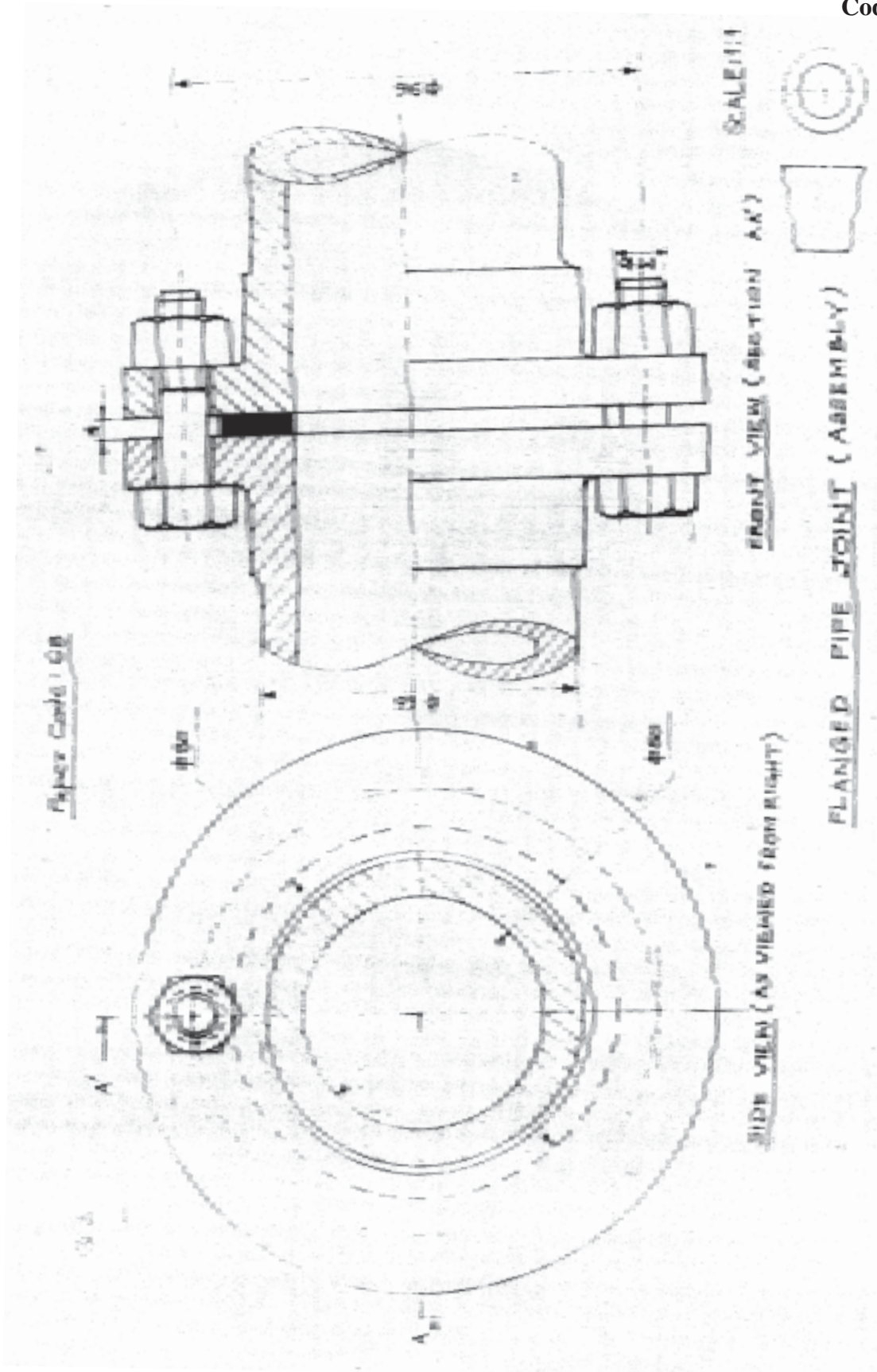

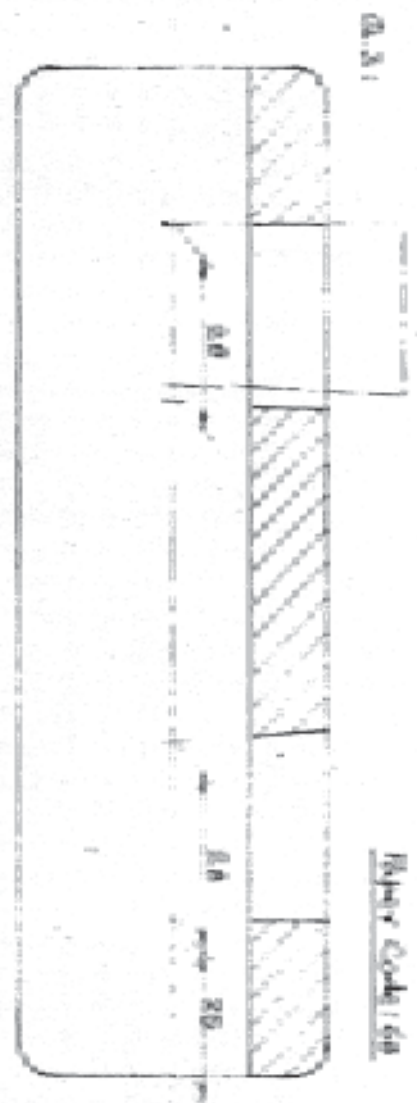

Sleeve Code: 68

FRONT VIEW (SECTION A-A)

SLEEVE

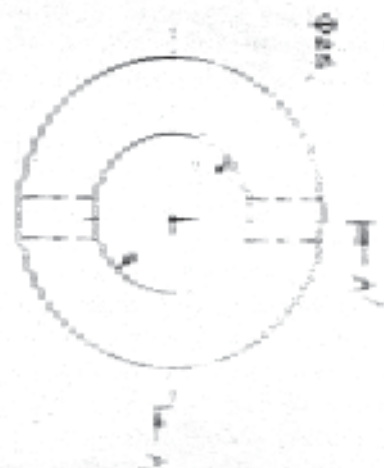

SIDE VIEW

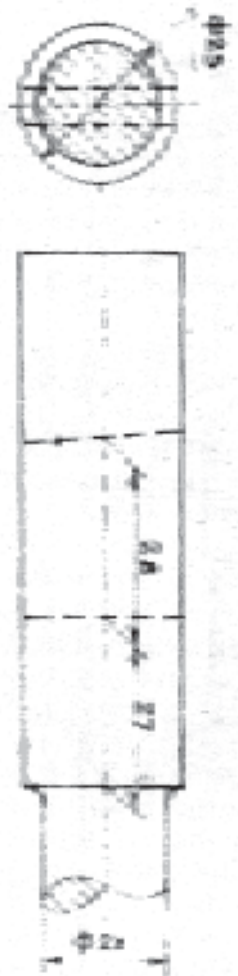

ROD-A

SCALE: 1:1

SLEEVE AND CUTTER JOINT (DIS-ASSEMBLY)





# MULTIMEDIA AND WEB TECHNOLOGY

*Time allowed : 3 hours*

*Maximum Marks : 70*

## Notes:

- (i) All questions are compulsory.
- (ii) Answer the questions after carefully reading the text.

## QUESTION PAPER CODE 89/1

1. (a) Name any two methods that can be used to create a table. 1
- (b) Explain the term attribute and degree with the help of an example 2
- (c) The relation Products is used to maintain some data related to products sold in a Grocery Store. Study the table and answer the following questions:

### Products

Prod_ID	Prod_name	Price	Category	Availability
711	Shine Toothpaste	35	SOAPS	20
234	Suqar	45	EDIBLE	52
424	Chocolate Box	125	EDIBLE	12
543	Detergent	62	SOAPS	26

- (i) Name the field that can act as a primary key in the table Products. 1
- (ii) If a separate table **Price** needs to be created to maintain information about each product's price, name any two fields from the above table that should be included in the new table. 1
- (iii) Name the type of relation that would exist between the table Products and the newly created table Price. 1
- (d) Give the full form of AVI. 1
- (e) Name any two audio formats that are most appropriate for using in web pages. 1
- (f) What is the difference between a file with .FLA extension and one with .SWF extension? 2

2. Questions below are based on Macromedia Flash:

- (a) Explain the use of the Guide Layer. 1
- (b) Differentiate between Layer and Timeline. 2
- (c) What is a blank key frame?
- (d) Give one advantage of dividing a movie into multiple scenes. 1
- (e) Name any two formats of which a flash movie can be published. 1
- (f) Observe the image given below and do as directed: 4

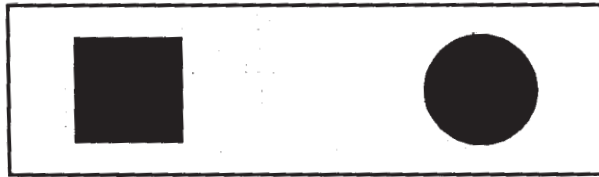

- The image on the left hand side shows the position and size for frame 1.
- The image on the right shows the image and size for frame 40.
- The shape on the left is blue in colour while the one on the right side is red in colour.

Write the procedure and property settings for animating the above scenario.

3. Answer the following questions based of HTML:

- (a) What is the difference between using the <EMBED> tag and <A> tag for adding music to a web page? 2
- (b) Write the HTML code to generate the web page in the format shown: 8

Consider the following points while writing the HTML code :

- (1) The title of the web page is Smart Uniforms.
- (2) The background colour of the web page is pink.
- (3) Text style of main heading is Papyrus and that of the rest of the page is Comic Sans MS.
- (4) The line is red in colour and 6 pixels thick.
- (5) The table has a blue coloured border that is 4 pixels thick.

- (6) Use the concept of nested lists for creating the given list.
- (7) The word online In the sentence above the table is hyperlinked to the page order.htm.
- (8) The image used is uniform.jpg.

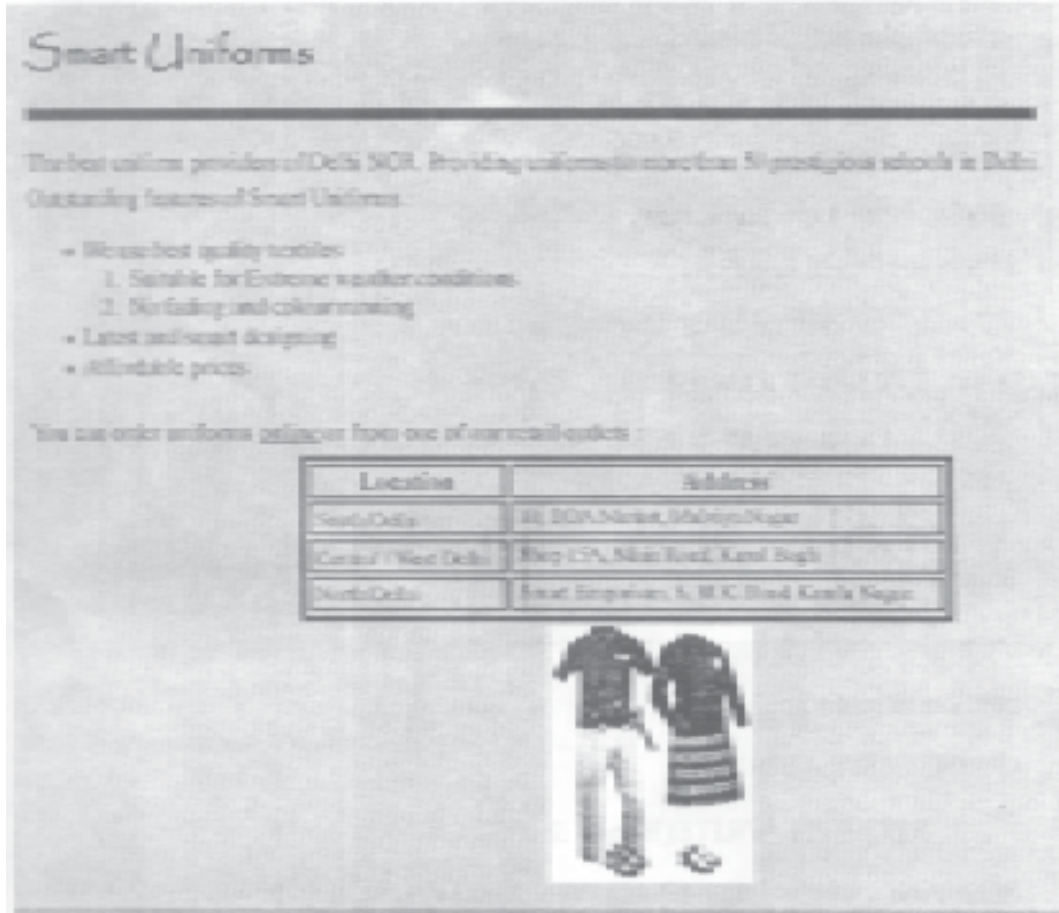

4. Answer the following questions based on ASP:
- (a) Name any two equivalent tools of ASP. 1
  - (b) Name the object of ASP object model used for handling errors. 1
  - (c) Name the object and its method: 3
    - (i) To send the buffered HTML output immediately.
    - (ii) To execute as ASP file.
    - (iii) That causes the browser to connect to a different web page.

- (d) Write the ASP statements to create a cookie named "Location" and store the value of "Jaipur" in it and retrieve the value stored in the cookie named "Location". 2
- (e) Give the output of the following statements: 3
- (i) Response.write((17-2\*3)\(15 MOD 4))
- (ii) Response.write(LCASE(MID("JigSaw Puzzle",3,6)))
- (iii) Response.write(MONTHNAME(MONTH("15/10/2011")+2))
5. Answer the following questions based on ASP.
- (a) What is the use of the FileSystemObject? 1
- (b) Give the full form of ODBC. 1
- (c) Predict the output of the following code: 2
- ```
<%
DIM cnt,num
List=ARRAY (14, 12, 32, 15, 8, 4, 2, 10)
FOR cnt = 7 to 1 STEP - 2
    Num =List( cnt) - List( cnt-1)
    RESPONSE.WRITE(num&"<BR>").
NEXT
%>
```
- (d) Rewrite the following code after removing all errors and underline each correction: 2
- ```
<%
option explicit
PROC DISPLAY(S1)
    REQUEST.WRITE(Happy&S 1)
End Proc
S= "Birthday"
call display(s)
>
```

- (e) FastnSafe Radio Taxis displays information about their service charges and distance between important location of the city using the content rotator component as shown below:

4

**FASTnSAFE Radio Taxis**

The Reliable Radio Taxi service that takes you to your destination quickly.

**Rajouri Garden to Connaught Place distance: 16 Km @ Rs. 10: Rs 160**

Create an ASP file "taxi. asp" with the above specification. The distance information is stored in a text file named routes.txt.

6. Answer the following questions based on VBScript:

- (a) Observe the following script:

2

```
<SCRIPTLANGUAGE= "VBSCRIPT">
```

```
OPTION EXPLICIT
```

```
DIM A,B
```

```
A = 10
```

```
B = 20
```

```
I = 1
```

```
DO WHILE I<=5
```

```
    C = B-A
```

```
    DOCUMENT.WRITE C
```

```
    A=A-1
```

```
    B=B+2
```

```
    I = I+1
```

```
LOOP
```

```
</SCRIPT>
```

Every time this script is executed, the programmer receives an error as soon as the FOR loop is reached. Identify the error and write the corrected code.

- (b) Rewrite the following code using a DO WHILE instead of FOR loop without affecting the output

2

```
<SCRIPT LANGUAGE="VBScript">  
  
DIM A  
  
A = 1  
  
FOR B = 1 to 10 STEP 3  
    A = A + B  
  
DOCUMENTWRITE(A & "<br>")  
  
NEXT  
  
</SCRIPT>
```

- (c) Predict the output of the following code:

2

```
<SCRIPT LANGUAGE="VBSCRIPT">  
  
DIM S, len1, len2  
  
s = "Play"  
  
len1 = len(s)  
  
FOR num=1 TO len1  
    DOCUMENTWRITE (LEFT(s,num))  
  
NEXT  
  
</SCRIPT>
```

- (d) Write HTML code to generated the following form:

4

<b>JAZZY DANCE ACADEMY</b>	
Enter Age of your child :	<input type="text"/>
FEE AMOUNT :	<input type="text"/>
<input type="button" value="CALCULATE"/>	

Write the VBScript code to display the fees for the Dance Course as

Rs. 600 for children aged 6 - 10

Rs. 1,000 for children aged 11 - 16

When the user clicks on the CALCULATE button. If the user enters any age other than the above then an error message "Not Eligible" should be displayed.

- 7 (a) Give two main advantage of star topology. .. 1.
- (b) Name any two wired transmission media. 1
- (c) Name an **Open Source** Software for the following Applications: 2
- (i) Database Management System
- (ii) Operating System
- (d) What is Video Conferencing? Name the main equipment required for it. 2
- (e) Gyan University is setting up its network in the new University campus located in Chandigarh. The campus has four main Buildings as shown in the diagram below: 2

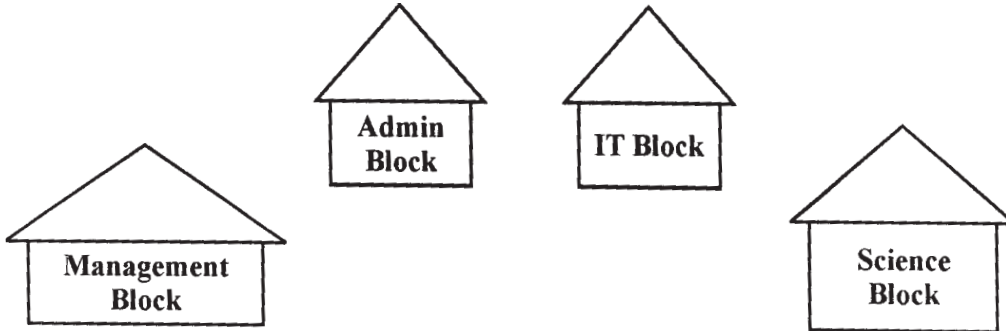

Centre to centre distance between various buildings is as follows:

Management Block to Admin Block	120 m
Admin Block to IT Block	100 m
IT Block to Science Block	90 m
Management Block to IT Block	160 m
Management Block to Science Block	180 m
Admin Block to Science Block	130 m

Number of Computer:

Management Block	50
Admin Block	160
IT Block	120
Science Block	100

- (i) Suggest a suitable cable layout of connections between buildings and name the topology used. 1
- (ii) Suggest the most suitable place (Wing) to house the server of this organization with a suitable reason. 1
- (iii) Where should repeaters be placed? 1
- (iv) Gyan University needs to be connected to the Gyan Engineering College located in N. Delhi. Suggest the most economical method of linking the head office and this office that can provide reliable communication. 1

**QUESTION PAPER CODE 89**

- 1 (a) Identify the most suitable data type for the following data-items : 1
  - (i) Age of a person
  - (ii) An Address
- (b) Explain the terms tuple and cardinality with the help of an example. 2
- (c) The relation *Nations* is used to maintain some statistics related to some nations of the world. Study the table and answer the following questions:

**Nations**

Nat_ID	Net_name	Population	Area	Status
A102	India	1.21 billion	3287	Developing
E054	Spain	0.05 billion	504	Developed
F062	Nigeria	0.16 billion	923	Developing
N013	Canada	0.04 billion	17075	Developed

- (i) Name the field that can act as a primary key in the table Nations. 1



- (ii) If a separate table *Population* needs to be created to maintain information about each country's population, name any two fields from the above table that should be include in the new table. 1
- (iii) Name the type of relation that would exist between the table Nations and the newly created table *Population*. 1
- (d) Give the full form of **MIDI**. 1
- (e) Name any two image formats that are most popularly used while designing web pages. 1
- (f) What is the difference between using a GIF image and a Flash movie in a web page? 2

2. Answer the following questions based on Macromedia Flash:

- (a) Explain the use of the Mask Layer. 1
- (b) Differentiate between symbol and instance. 2
- (c) What is a key frame? 1
- (d) Give one advantage of using layers in Flash. 1
- (e) Name two formats to which a Flash movie can be published. 1
- (f) Observe the image given below and do as directed: 4

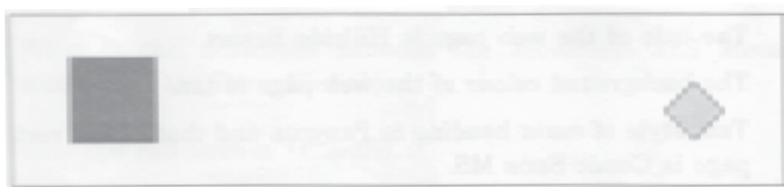

- The image on the left hand side shows the position and size for frame 1.
- The image on the right shows the image and size for frame 40.
- The shape on the left is blue in colour while the one on the right side is orange in colour.

Write the procedure and property settings for animating the above scenario.

3. Answer the following questions based on HTML :

- (a) What is the difference between <FONT> and <BASEFONT> tags? 2

(b) Write the HTML code to generate the web page in the format shown:

8

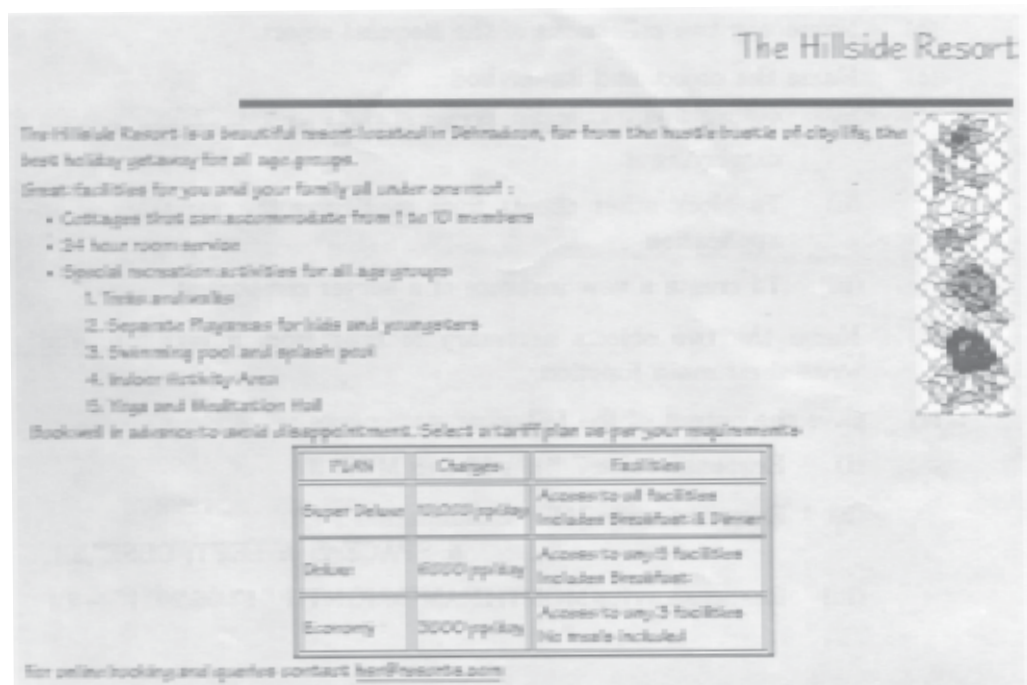

Consider the following points while writing the HTML code:

1. The title of the web page is Hillside Resort.
2. The background colour of the web page is tan.
3. Text style of main heading is Papyrus and that of the rest of the page is Comic Sans MS.
4. The image used is flowers.jpg
5. The line is green in colour and 6 pixels thick.
6. The table has a blue coloured border that is 4 pixels thick.
7. Use the concept of nested lists for creating the given list.
8. The link at the bottom is an e-mail link to the address [HSR@resorts.com](mailto:HSR@resorts.com)

4 Answer the following questions based on ASP:

- (a) Give one reason why server side scripting is essential. 1
- (b) Name any two collections of the Request Object. 1
- (c) Name the object and its method: 3

- (i) To clear the buffered HTML output of a response without displaying it
  - (ii) To block other clients from modifying the variables of an application
  - (iii) To create a new instance of a server component ..
- (d) Name the two objects necessary to read from a text file. Also write their main function. 2
- (e) Give the output of the following statements: 3
- (i) Response.write(7 \* 6 - 121 ( 8 MOD 3 ))
  - (ii) Response.write(MID("Examination", 4,3) & SPACE(2) & LEFT("CBSE",2))
  - (iii) Response.write(MONTHNAME(MONTH("17/06/2011 ") + 3))

5. Answer the following questions based on ASP:

- (a) What is the difference between the MoveNext and Movelast methods of the RecordSet object? 1
- (b) Give the full form of OLE-DB. 1
- (c) Predict the output of the following code: 2

```
<%
DIM cnt,num
List = ARRAY (30, 15, 25, 10, 20, 40, 12, 16)
FOR cnt=0 to 6 STEP 2
    Num= List (cnt) + List (cnt+1)
    RESPONSE.WRITE(num & "<BR>")
NEXT
%>
```

- (d) Rewrite the following code after removing all errors and underline each correction: 2

```
<%
DIM A = 30
DO A > 0
    SUM = SUM + F1 (A)
```

```
RESPONSE. DISPLAY ("SUM = " & SUM)
```

```
A = A - 10
```

```
LOOP
```

```
FUNCTION F1 (NUM)
```

```
    F1 = NUM MOD 6
```

```
END
```

```
%>
```

- (e) **BLOOM** cards uses banner advertisements to fund their web site as shown below

4

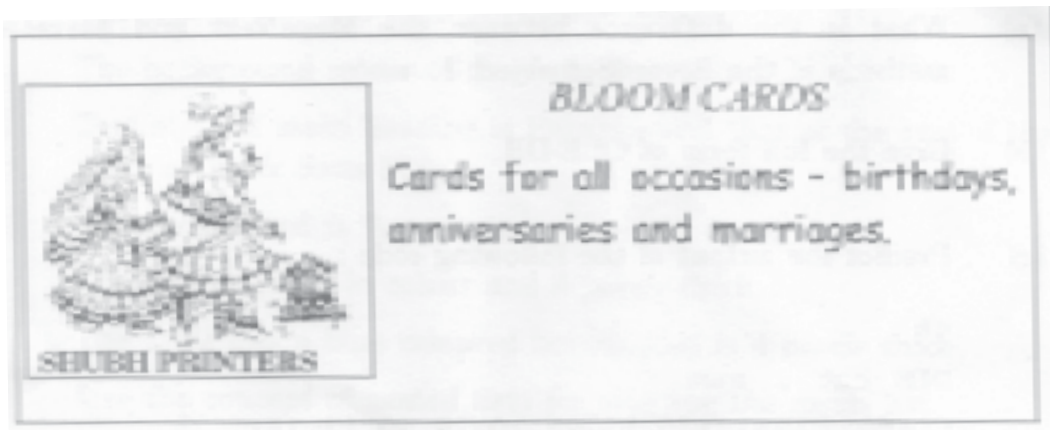

Create an ASP file "Greeting.asp" to display different banner advertisement on the web page. The ads to be displayed are stored in the file myads.txt.

- 6 Answer the following questions based on **VBSCRIPT**:

- (a) What is event handing? Name the event that occurs when the mouse cursor is brought over an element on a web page.

2

- (b) Rewrite the following code using a **DO WHILE** instead of FOR loop without affecting the output:

2

```
<%
```

```
    DIM prod
```

```
    prod = 1
```

```
    FOR n = 6 TO 1 step - 2
```

```
        Prod = prod * 2
```

```
    RESPONSE. WRITE (prod & "<BR>")
```

NEXT

%>

- (c) Predict the output of the following code:

2

```
<SCRIPT LANGUAGE="VBSCRIPT">
```

```
DIM S1 , S2, LEN1, LEN2
```

```
S1 = "Happy"
```

```
S2 = "Anniversary"
```

```
LEN1 = LEN(S1)
```

```
LEN2 = LEN(S2)
```

```
IF LEN2 MOD LEN1 = 0 THEN
```

```
    DOCUMENT.WRITE (S1 & S2)
```

```
ELSE
```

```
    DOCUMENT.WRITE (S2 & S1)
```

```
END IF
```

```
</ SCRIPT>
```

- (d) Write the **HTML** code to generate the following form:

4

<b>PTM DATE CHECK</b>	
<b>Enter class of your ward:</b>	<input type="text"/>
<b>PTM DATE :</b>	<input type="text"/>
<input type="button" value="GET PTM DATE"/>	

Write the VBScript code to display the PTM data on the click of the GET PTM DATE button as :

12/10/2012 if class entered is between 1 to 6 and

15/10/2012 if class is between 7 to 12

If the user enters any class other than the above then an error message should be displayed.

7. (a) What is a network topology? 1
- (b) Name any two modes of wireless transmission media. 1
- (c) What are the following software used for : 2
- (i) PHP
- (ii) GNU
- (d) What is a firewall? What is its use? 2
- (e) FurturZ Software Company has set up its new centre at New Delhi for its office and web based activities. It has 4 blocks of buildings as shown:

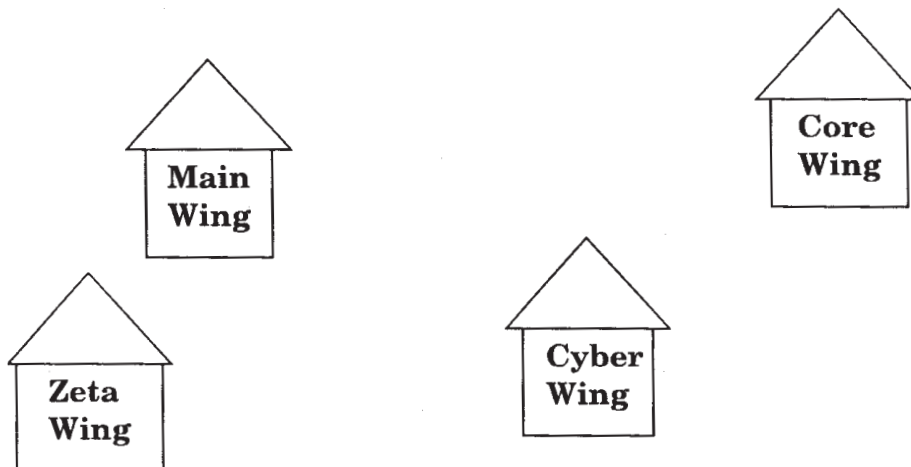

Centre to centre distances between various buildings is as follows

Main Wing to Zeta Wing	80 m
Zeta Wing to Cyber Wing	100 m
Cyber Wing to Core Wing	40 m
Main Wing to Cyber Wing	120 m
Zeta Wing to Core Wing	150 m
Main Wing to Core Wing	130 m

Number of Computers:

Main Win	50
Zeta Win	40
Cyber Win	250
Core Win	100

- (i) Suggest a cable layout of connections between buildings and name the topology used 1
- (ii) Suggest the most suitable place (Wing) to house the server of this-organization with a suitable reason. 1
- (iii) Where should the repeaters be placed ? 1
- (iv) The parent company of FuturZ Software Company is situated in Hyderabad. Suggest the most economical method of linking the head office and this office that can provide fast communication. 1

# Marking Scheme — Multimedia and Web Technology

(SUB CODE -067)

## General Instructions :

- Marking Scheme is the final document for all references with regard to evaluation and cannot be altered under any circumstances
- The answers given in the marking scheme are SUGGESTIVE, Examiners are requested to award marks for all alternative correct Solutions/Answers conveying the similar meaning
- In VBScript and ASP, ignore case sensitivity for identifiers (Variable/Sub routines/ Functions)
- In HTML, ignore case sensitivity, spaces and spelling errors in HTML tags (that sound same) and attributes (Example: <BODY bgcolor> and <body bg color> and <FORNT> are acceptable)

## QUESTION PAPER CODE 89/1

- 1 (a) Name any two methods that can be used to create a table 1

Ans Methods for creating a table are:

1. Using the Design view
2. Using the Datasheet view / By entering data
3. Using the Wizard

(% mark each for mentioning any two methods correctly)

- (b) Explain the term attribute and degree with the help of an example 2

Ans Attribute refers to the column of a table. It is the property under which the data is categorized. Degree is the number of attributes in a table.

Prod_ID	Frod_name	Price	Category	Availability
711	Saine Toothpaste	35	SOAPS	20
234	Sugar	45	EDIBLE	52
424	Caocolate Box	125	EDIBLE	12
543	Detergent	62	SOAPS	26



*(1 mark each for the correct definition of each of the two terms)*

**NOTE: Full marks to be awarded in case both the concepts are explained only with the help of an example.**

- (c) The relation Products is used to maintain some data related to products sold in a Grocery Store. Study the table and answer the following questions:

Prod ID	Prod name	Price	Category	Availability
711	Shine Toothpaste	35	SOAPS	20
234	Sugar	45	EDIBLE	52
424	Chocolate Box	125	EDIBLE	12
543	Detergent	62	SOAPS	26

- (i) Name the field that can act as a primary key in the table Products. 1

Ans The field  can act as the primary key in the table

**OR**

The field prod name can act as the primary key in the table

*(1 mark for naming the correct field)*

- (ii) If a separate table Price needs to be created to maintain information about each product's price, name any two fields from the above table that should be included in the new table. 1

Ans  **OR**  ..

*(1/2 mark each for naming the two fields correctly)*

- (iii) Name the type of relation that would exist between the table Products and the newly created table Price. 1

Ans

*(1 mark for naming the correct type of relation)*

- (d) Give the full form of AVI. 1

Ans Audio Video Interleave

*(1 mark for the correct expansion)*

**NOTE: 1/2 mark if any two words are expanded correctly like Audio Visual Interleave**

(e) Name any two audio formats that are most appropriate for using in web pages. 1

Ans WAV / MP3 / MP4 / MIDI / AIFF / ASF or any other correct format

*(½ mark each for naming any two sound formats correctly)*

(f) What is the difference between a file with .FLA extension and one with .SWF extension? 2

Ans A Flash file can be edited whereas the SWF file cannot be edited.

*(2 marks for anyone correct differentiation point between the two)*

*NOTE: 1½ marks to be awarded in case only the extension of both formats is given i.e. Flash file and Shock Wave File*

2. Questions below are based on Macromedia Flash:

(a) Explain the use of the Guide Layer. 1

Ans. A guide layer is used to assign an animation path that links to an object placed on another layer during motion tweening.

**OR**

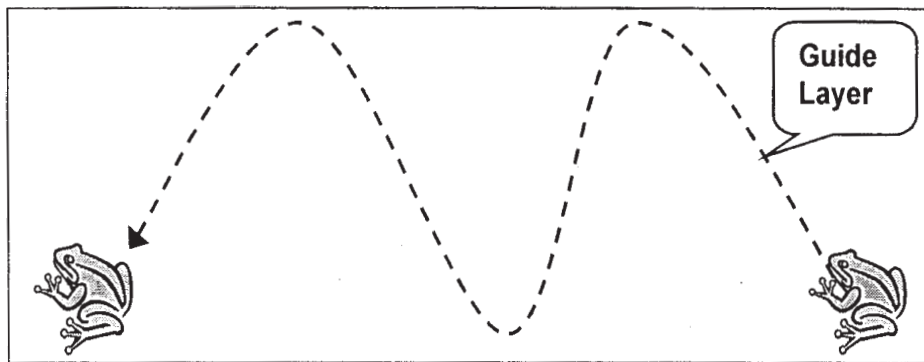

*(1 mark for the correct usage)*

*NOTE: No marks to be deducted if the concept is explained with the help of a diagram*

(b) Differentiate between Layer and Timeline. 2

Ans A layer is an organization device that allows one to separate the content of a movie into manageable sizes whereas the timeline represents the chronological order of frames in a movie

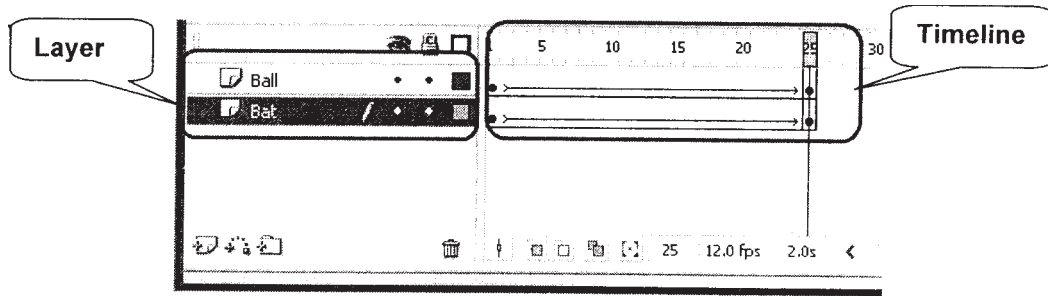

*(2 marks for anyone correct differentiation point between the two)*

**NOTE:** *No marks to be deducted if both the concepts are explained graphically*

(c) What is a blank key frame?

Ans A blank key frame is a key frame with no content

**OR**

A blank key frame is a key frame that is waiting to be filled with content

**OR**

A key frame with no content that is essential for situations when the preceding content differs totally from the previous frames.

**OR**

A blank keyframe is denoted by a hollow dot in the timeline

**OR**

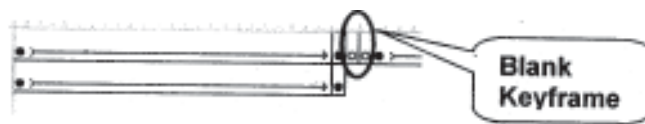

*(1 mark for the correct definition)*

**NOTE:** *No marks to be deducted if the concept is explained graphically*

(d) Give one advantage of dividing a movie into multiple scenes.

1

Ans To make editing simple/easy

**OR**

To make a movie easy to handle/maintain/manage

**OR**

Each scene has their independent timeline thereby making the editing process simpler.

*(1 mark for mentioning anyone advantage correctly)*

- (e) Name any two formats of which a flash movie can be published. 1

Ans. MOV / .GIF / .JPEG / .HQX / .SWF / .HTML / .PNG / .SMIL / .EXE

*(½ mark each for naming any two of the above mentioned formats correctly)*

- (f) Observe the image given below and do as directed: 4



- The image on the left hand side shows the position and size for frame 1.
- The image on the right shows the image and size for frame 40.
- The shape on the left is blue in colour while the one on the right side is red in colour.

Write the procedure and property settings for animating the above scenario.

- Ans. ● **Select frame 1** from the time line and select Insert a new Symbol > Graphic
- Create the **blue coloured square** on the stage using the rectangle tool on the left hand side.
  - Insert an instance of this symbol in frame 1.
  - **Select frame 40** from the timeline and **Select Insert → Keyframe**
  - Using the arrow tool, **Select and Delete the square**
  - Use the oval tool to **Create a red coloured circle symbol** and place it on the right hand side of the stage at the desired location
  - **Select all frames from 1 to 40.**
  - Open the tween panel and choose **Create Shape Tween.**

**OR Any other equivalent method.**

(½ mark for each step)

**Note: Full marks to be awarded if the child has written the highlighted portions in the above steps instead of writing complete sentences**

3. Answer the following questions based of HTML:

- (a) What is the difference between using the <EMBED> tag and <A> tag for adding music to a web page? 2

Ans The <EMBED> tag places the music within the web page whereas the <A> tag is used to create a hyperlink to a music file that resides on some other web page.

**(2 marks for anyone correct differentiation point between the two)**

**NOTE: 1 mark if usaae of only one of the tags is explained**

- (b) Write the HTML code to generate the web page in the format shown: 8

The screenshot shows a website for 'Smart Uniforms'. The header includes the company name and a tagline: 'The best online provider of Delhi NCR. Providing uniforms to more than 50 prestigious schools in Delhi'. Below this, it lists 'Outstanding features of Smart Uniforms' with a bulleted list: '• We use best quality textiles', '1. Suitable for Extreme weather conditions', '2. No fading and colour running', '• Latest and smart designing', and '• Affordable prices'. A text prompt says 'You can order uniforms online from one of our retail outlets:'. This is followed by a table with two columns: 'Location' and 'Address'. The table contains three rows of data. Below the table is an image showing a male and a female school uniform set.

Location	Address
South Delhi	20, DDA Market, Okhla, Noida
Central / West Delhi	Block 17A, Noida Road, Kirti Nagar
North Delhi	Block 17A, Noida Road, Kirti Nagar

- The title of the web page is Smart Uniforms.
- The background colour of the web page is pink.
- Text style of main heading is Papyrus and that of the rest of the page is Comic Sans MS.
- The line is red in colour and 6 pixels thick.
- The table has a blue coloured border that is 4 pixels thick.
- Use the concept of nested lists for creating the given list.
- The word online In the sentence above the table is hyperlinked to the page order.htm.
- The image used is uniform.jpg.

Ans. <HTML>

<HEAD>

<TITLE>Smart Uniforms</TITLE>

(½ mark)

</HEAD>

<BODY BGCOLOR="pink">

(½ mark)

<FONT FACE="papyrus">

(½ mark)

<H1 ALIGN="left">Smart Uniforms</H1>

(½ mark)

<HR SIZE=6 WIDTH="50%" COLOR="red">

(1 mark)

<BR>

<FONT FACE="COMIC SANS MS">

The best uniform providers of Delhi NCR. Providing uniforms to more than 50 prestigious schools in Delhi

<P> Outstanding features of Smart Uniforms:

<BR>

<UL>

<LI> We use best quality textiles

(1 mark)

<OL>

<LI> Suitable for Extreme weather conditions

<LI> No fading and colour running

</OL>

<LI> Latest and smart designing

<LI> Affordable prices

</UL>

<BR>

1 mark

You can order uniforms [online](booking.htm) or from one of our retail outlets:

<CENTER>

<TABLE BORDER = 4 BORDERCOLOR="blue">

1 mark

<TH>Location <TH> Address

<TR>

<TO> South Delhi

<TO> 10, DDA Market, Malviya Nagar

<TR>

<TO> Central/West Delhi

1 mark

<TO> Shop 15A, Main Road, Karol Bagh

<TR>

<TO> North Delhi

<TO> Smart Emporium, 6, M.K. Road, Kamla Nagar

</TABLE>

<IMG SRC = "school\_uniform.gif">

1 mark

</CENTER>

Conditional

</BODY>

½ mark

</HTML>

- (1/2 mark for correct use of <TITLE> tag)*
  - + (1/2 mark for body background colour)*
  - + (1/2 mark for mentioning the correct font type for either heading or web page)*
  - + (1/2 mark for displaying the heading correctly on the left)*
  - + (1 mark for drawing the horizontal line)*
  - + (1 mark for displaying the image correctly in the center)*
  - + (1 mark for correctly creating the nested list (% mark for each list))*
  - + (1 mark for making table border 4 pixel thick with border color blue)*
  - + (1 mark for correctly creating the table using <TR> and <TD> tags)*
  - + (1 mark for correctly creating the link on the text)*
- Note: 1 mark to be awarded for correct use of <HTML> and <BODY> tags if any of the above mentioned tags are not given properly**

4. Answer the following questions based on ASP:

- (a) Name any two equivalent tools of ASP. 1

Ans PHP / JSP / PERL / CGI / Python / Cold Fusion

*(1/2 mark each for any two correct equivalent tools)*

- (b) Name the object of ASP object model used for handling errors. 1

Ans	(Full 1 Mark)	(1/2 Mark)
	ASPError Object	Error Object OR Error
	OR	OR
	ASPError	ErrorASP Object OR ErrorASP

*(1 mark for mentioning the correct object)*

**Note: 1/2 mark to be awarded for partially correct answer like Error Object OR Error ASP Object**

- (c) Name the object and its method: 3

- (i) To send the buffered HTML output immediately.



- (ii) To execute as ASP file.
- (iii) That causes the browser to connect to a different web page.

- Ans (i) Object: Response                      Method: Flush
- (ii) Object: Server                              Method: Execute
- (iii) Object: Response                        Method: Redirect

*(1/2 mark each for naming the Object and Method correctly for each part)*

- (d) Write the ASP statements to create a cookie named "Location" and store the value of "Jaipur" in it and retrieve the value stored in the cookie named "Location". 2

```
Ans <% Response.Cookie("Location")= "Jaipur"
Request.Cookie("Location")
%>
```

*(1 mark for creating the cookie)*

*+(1 mark for retrieving the value)*

*Note: Marks should not be deducted if the variables/values are not enclosed in quotes or are enclosed in single quotes*

- (e) Give the output of the following statements: 3
- (i) Response.write((17-2\*3)\(15 MOD 4))
  - (ii) Response.write(LCASE(MID("JigSaw Puzzle",3,6)))
  - (iii) Response.write(MONTHNAME(MONTH("15/10/2011")+2))

Ans.	(Full 1 Mark)	(1/2 Mark)
(i)	3	11
(ii)	gsaw p	gSaw P <b>OR</b> Saw Pu <b>OR</b> saw pu
(iii)	December	October

*(1 mark for each correct output of each part)*

*NOTE: 1/2 mark for any other partially correct answer*

5. Answer the following questions based on ASP.

- (a) What is the use of the FileSystemObject? 1

Ans The FileSystemObject provides access from an ASP script to the file stored on the hard disk.

**OR**

It allows the user to work with text files

**OR**

It includes all the basic methods for working with the text file system

*(1 mark for the correct usage)*

(b) Give the full form of ODBC.

1

Ans Open Database Connectivity

*(1 mark for the correct expansion)*

**NOTE:** *½ mark if any two words are expanded correctly like Open Database Connection*

(c) Predict the output of the following code:

2

```
<%
DIM cnt,num
List=ARRAY (14, 12, 32, 15, 8, 4, 2, 10)
FOR cnt = 7 to 1 STEP - 2
    Num =List( cnt) - List( cnt-1)
    RESPONSE.WRITE(num&"<BR>").
NEXT
%>
```

Ans	<i>(Full 2 Marks)</i>	<i>(1½ Marks)</i>	<i>(1 Mark)</i>
	8	8 - 4 -17 - 2	8
	- 4	<b>OR</b>	4
	-17	8 - 4 -17 - 2	17
	- 2		2
			<b>OR</b>
			8 4 17 2
			<b>OR</b>
			8 4 17 2

*(1/2 mark for each correct value of the output)*

*Note: 1/2 mark to be deducted if the numbers are given on the same line 1 mark to be deducted if the sign is missing in front of the negative numbers*

- (d) Rewrite the following code after removing all errors and underline each correction: 2

```
<%  
option explicit  
PROC DISPLAY(S1)  
    REQUEST.WRITE(Happy&S 1)  
End Proc  
S= "Birthday"  
call display(s)
```

Ans <%

option explicit

Either the statement removed or type  
new statement just below DIM S

```
SUB DISPLAY(S1)  
    RESPONSE.WRITE( "Happy_" & S1)  
End SUB  
S= "Birthday"  
call display(s)  
%>
```

*(1/2 mark each for correcting any four out of six corrections shown above)*

**OR**

*(1 Mark for only identifying any four errors)*

**NOTE: Marks should not be deducted for mentioning any other error/ correction**

- (e) FastnSafe Radio Taxis displays information about their service charges and distance between important location of the city using the content rotator component as shown below:

4

**FASTnSAFE Radio Taxis**

The Reliable Radio Taxi service that takes you to your destination quickly.

**Rajouri Garden to Connaught Place distance: 16 Km @ Rs. 10: Rs 160**

Create an ASP file "taxi. asp" with the above specification. The distance information is stored in a text file named routes.txt.

Ans <HTML>

<BODY>

<CENTER> <H1>FASTnSAFE Radio Taxis</H1> </CENTER>

<P>

The Reliable radio Taxi- service that takes you to your destination quickly

<%

Set myCont=Server. CreateObject(IIMSWC. ContentRotator")

%>

<PALIGN="CENTER"><% =my~nt.ChooseContent(lroutes.txt") %>

</BODY>

</HTML>

OR Response. Write (myCont. ChooseContent("routes. txt"))

*(1 mark for correct <H1> tag)*

*(1 mark for displaying the text)*

*(1 mark for correct usage of CreateObject)*

*(1 mark for correct usage of ChooseContent)*

6. Answer the following questions based on VBScript:

- (a) Observe the following script:

<SCRIPTLANGUAGE="VBSCRIPT">

2

```

OPTION EXPLICIT
DIM A,B
A = 10
B = 20
I = 1
DO WHILE I<=5
    C = B-A
    DOCUMENT.WRITE C
    A=A-1
    B=B+2
    I=I+1
LOOP
</SCRIPT>

```

Every time this script is executed, the programmer receives an error as soon as the FOR loop is reached. Identify the error and write the corrected code.

Ans **Option 1:**

The error occurs because the variables I and C are undefined. There are two possible solutions:

1. Remove the OPTION EXPLICIT command from the script
2. Declare both the variables I and C using the DIM command as shown below:

```
DIM I, C
```

*(1 mark for identifying the error and 1 mark for correcting it using anyone of the above mentioned method)*

**OR**

**Option 2:**

Error in question as no FOR loop exists in the code

*(Full two marks for pointing out error in the question)*

- (b) Rewrite the following code using a DO WHILE instead of FOR loop without affecting the output

2

```
<SCRIPT LANGUAGE="VBScript">  
  
DIM A  
  
A = 1  
  
FOR B = 1 to 10 STEP 3  
    A = A + B  
  
DOCUMENTWRITE(A & "<br>")  
  
NEXT  
  
</SCRIPT>
```

Ans <SCRIPT LANGUAGE="VBScript">

```
DIM A  
  
A = 1  
  
B = 1  
  
DO WHILE B <= 10  
    A=A+B  
    DOCUMENTWRITE(A & "<br>")  
    B = B + 3  
  
LOOP  
  
</SCRIPT>
```

*(1/2 mark for making each of the four underlined corrections)*

- (c) Predict the output of the following code:

2

```
<SCRIPT LANGUAGE="VBSCRIPT">  
  
DIM S, len1, len2  
  
s = "Play"  
  
len1 = len(s)
```

```
FOR num=1 TO len1
    DOCUMENTWRITE (LEFT(s,num))
NEXT
</SCRIPT>
```

Ans P PI Pia Play OR PPIPlaPlay

OR

P

PI

Pia

Play

*(1/2 mark for each correct underlined word in the output)*

**Note: No marks to be deducted for wrong case or for writing the output on separate lines**

(d) Write HTML code to generated the following form:

4

Write the VBScript code to display the fees for the Dance Course as

Rs. 600 for children aged 6 - 10

Rs. 1,000 for children aged 11 - 16

When the user clicks on the CALCULATE button. If the user enters any age other than the above then an error message "Not Eligible" should be displayed.

<b>JAZZY DANCE ACADEMY</b>	
Enter Age of your child :	<input type="text"/>
FEE AMOUNT :	<input type="text"/>
<input type="button" value="CALCULATE"/>	

Ans <HTML>

<HEAD><SCRIPT LANGUAGE="vbscript">

**sub b1\_OnClick**

**age=f1.t1.value**

```
SELECT CASE age
CASE 6,7,8,9, 10
    fee = 600
CASE 11,12,13,14,15,16
    fee=1000
CASE ELSE
    document.write "Not Eligible"
END SELECT
```

OR

```
IF age>=6 AND age<=10 THEN
    fee=600
ELSE IF age >= 6 AND age <= 10 THEN
    fee=1000
ELSE
    MSGBOX "Not Eligible"
END IF
END IF
```

**f1.t2.value = fee**

**END SUB**

</SCRIPT></HEAD>

<BODY>

**<FORM NAME="f1 ">**

**<P ALIGN=CENTER>**

**<B>JAZZY DANCE ACADEMY**

**<P>**

Enter Age of your child:

**<INPUT TYPE = "TEXT" NAME="t1">1**

**<BR><BR>**

FEE AMOUNT : **<INPUT TYPE="TEXT" NAME="t2">**

**<BR><BR>**

**<CENTER>**



```
<INPUT TYPE="BUTTON" VALUE="CALCULATE" name="b1">
```

```
</FORM> </BODY> </HTML>
```

*(1/2 mark for the <FORM> tag)*

*(1/2 mark for creating the textbox)*

*(1/2 mark for creating the button)*

*(1/2 mark for associating the subroutine with the button element)*

*(1/2 mark for extracting the value and storing it in a variable)*

*(1 mark for the conditional statement - IF or SELECT CASE)*

*(1/2 mark for displaying the fee in the text box)*

**NOTE:** No marks to be deducted if *f1.t1.value/f1.t2.value* is used in all places instead of using a variable

7 (a) Give two main advantage of star topology. .. 1.

Ans Two main advantages of star topology are:

1. Easy to install and wire
2. Easy to detect faults and to remove parts / Easy to troubleshoot
3. Highly reliable

Or any other valid advantage

*(1/2 mark each for any two correct advantages)*

(b) Name any two wired transmission media. 1

Ans Optical fibre cable / Twisted pair cable / Co-axial cable / HDMI cable / CAT5

**OR** any other correct cable type

*(1/2 mark each for naming any two wired transmission media)*

(c) Name an **Open Source** Software for the following Applications: 2

Database Management System

Operating System

- Ans (i) MySQL / Postgre SQL / Postgre  
(ii) GNU / LINUX / Android Mobile Operating System / Darwin / Chrome  
**OR** any other correct Open Source DBMS or Operating System

*(1 mark for naming the correct software for each part)*

- (d) What is Video Conferencing? Name the main equipment required for it. 2

Ans Video Conferencing provides real time video and voice communication between terminals, over a network. The main equipment required is webcam, microphone and a personal computer.

*(1 mark for the correct definition)*

*(1 mark for mentioning the correct equipment - any two)*

- (e) Gyan University is setting up its network in the new University campus located in Chandigarh. The campus has four main Buildings as shown in the diagram below: 2

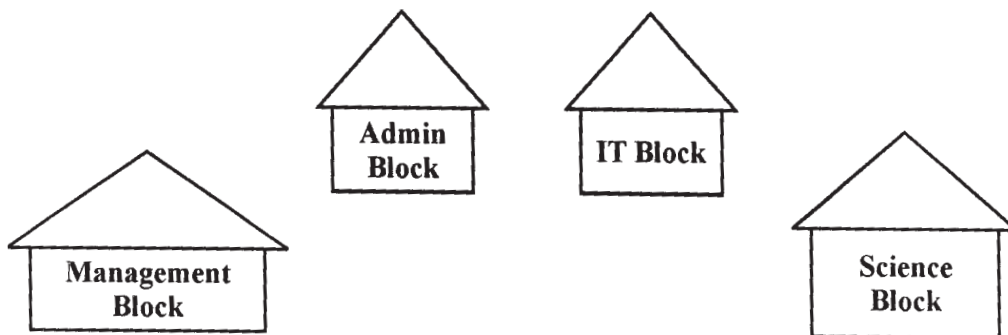

Centre to centre distance between various buildings is as follows:

Management Block to Admin Block	120 m
Admin Block to IT Block	100 m
IT Block to Science Block	90 m
Management Block to IT Block	160 m
Management Block to Science Block	180 m
Admin Block to Science Block	130 m

Number of Computer:

Management Block	50
Admin Block	160
IT Block	120
Science Block	100

- (i) Suggest a suitable cable layout of connections between buildings and name the topology used.

1

Ans

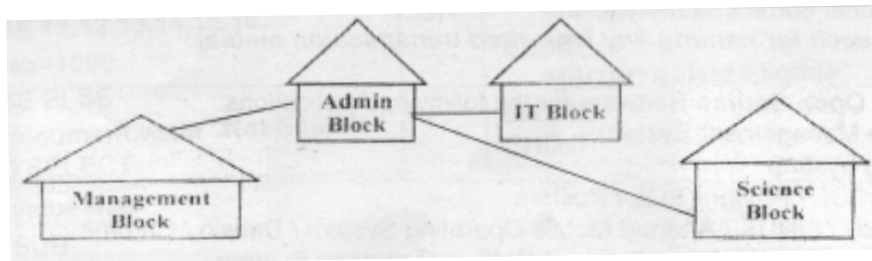

**OR** Star topology is the most suitable.

*(1 Mark for drawing /writing any valid connectivity or topology or diagram connecting various buildings inside the campus)*

**NOTE:** Ignore placement/order of buildings in the diagrammatic representation

- (ii) Suggest the most suitable place (Wing) to house the server of this organization with a suitable reason.

1

Ans Admin Block is the most suitable place to house the server as. it has the maximum number of computers.

**OR**

Admin Block since it is closest to the other three buildings

*(1/2 Mark for writing correct place)*

*(1/2 Mark for correct justification)*

- (iii) Gyan University needs to be connected to the Gyan Engineering College located in N. Delhi. Suggest the most economical method of linking the head office and this office that can provide reliable communication.

1

Ans Radio waves **OR** TCP/IP or dial-up connection

*(1 mark for suggesting the most economical method)*

QUESTION PAPER CODE 89

- 1 (a) Identify the most suitable data type for the following data-items : 1
- (i) Age of a person
  - (ii) An Address

Ans The most suitable data type is:

- (i) Age of a person - Number
- (ii) An Address – Text

*(1/2 mark each for mentioning both the data types correctly)*

- (b) Explain the terms tuple and cardinality with the help of an example. 2

Ans Tuple refers to a record of a table. Cardinality is the number of tuples in a table

*Nations*

Nat 10	Nat name	Population	Area
A102	India	1.21 billion	3287
E054	Spain	0.05 billion	504
F062	Nigeria	0.16 billion	923
N013	Canada	0.04 billion	17075

Table

Cardinality = 4

*(1 mark each for the correct definition of each of the two terms)*

**NOTE: No marks to be deducted in case both the concepts are explained only with the help of an example.**

- (c) The relation *Nations* is used to maintain some statistics related to some nations of the world. Study the table and answer the following questions:

**Nations**

Nat_ID	Net_name	Population	Area	Status
A102	India	1.21 billion	3287	Developing
E054	Spain	0.05 billion	504	Developed
F062	Nigeria	0.16 billion	923	Developing
N013	Canada	0.04 billion	17075	Developed

(i) Name the field that can act as a primary key in the table Nations. 1

Ans The field  can act as the primary key in the table

**OR**

The field  can act as the primary key in the table

*(1 mark for naming the correct field)*

(ii) If a separate table **Population** needs to be created to maintain information about each country's population, name any two fields from the above table that should be include in the new table. 1

Ans  OR

*(1/2 mark each for naming the two fields correctly)*

(iii) Name the type of relation that would exist between the table Nations and the newly created table **Population**. 1

Ans

*(1 mark for naming the correct type of relation)*

(d) Give the full form of **MIDI**. 1

Ans Musical Instrument Digital Interface

*(1 mark for the correct expansion)*

**NOTE: 1/2 mark if any two words are expanded correctly like Musical Instrument Data Interaction OR Musical Instrument Digital Interaction**

(e) Name any two image formats that are most popularly used while designing web pages. 1

Ans JPEG / JPG / GIF / TIFF / PNG / or any other correct format

*(1/2 mark each for naming any two image formats correctly)*

(f) What is the difference between using a GIF image and a Flash movie in a web page? 2

Ans. A Flash movie can be stopped or restarted by the user while in GIF user interaction is not possible

**OR**

It is very easy to edit a Flash movie, while editing of GIF animation is not possible

*(2 marks for anyone correct differentiation point between the two)*

*NOTE: 1 mark if only one of the term is explained*

2. Answer the following questions based on Macromedia Flash:

(a) Explain the use of the Mask Layer.

1

Ans A mask layer is used to hide any layers linked to it

**OR**

A mask layer is used to show portions of underlying layer through the mask design while other parts remain hidden

**OR**

A mask layer is used to show certain portions and hide the rest of the layer

**OR**

A mask layer is used to create a binocular effect where selected portions of the underlying layer are visible

*(1 mark for the correct usage)*

*NOTE: No marks to lie deducted if the concept is explained with the help of an illustration*

(b) Differentiate between symbol and instance.

2

Ans Symbol is a reusable object stored in the flash library whereas an instance is a copy of the symbol place on the stage.

**OR**

Symbol is stored in the flash library whereas an instance is placed on the stage

*(2 marks for anyone correct differentiation point between the two)*

*NOTE: 1 mark if only one of the terms is explained*

(c) What is a key frame?

1

Ans A key frame is a frame that marks a change in an object's properties from the preceding frame.

**OR**

Key frames mark a change and are denoted by a solid dot in the timeline

**OR**

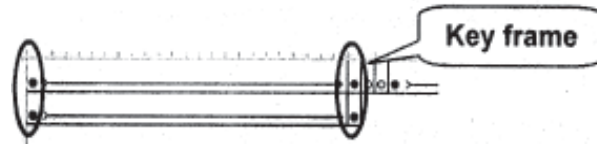

*(1 mark for the correct definition)*

**NOTE: No marks to be deducted if the concept is explained graphically**

- (d) Give one advantage of using layers in Flash. 1

Ans Layer is an organization device that allows one to separate the content of a scene into manageable objects.

**OR**

Layer allows one to place different objects on different layers so that they can be handled independently

**OR**

Layer allows one to place different objects in different areas so that they can be handled independently without affecting each other

*(1 mark for mentioning anyone advantage correctly)*

- (e) Name two formats to which a Flash movie can be published. 1

Ans MOV / GIF / .JPEG / .HQX / .SWF / .HTML / .PNG / .SMIL / .EXE

*(1/2 mark each for naming any two of the above mentioned formats correctly)*

- (f) Observe the image given below and do as directed: 4

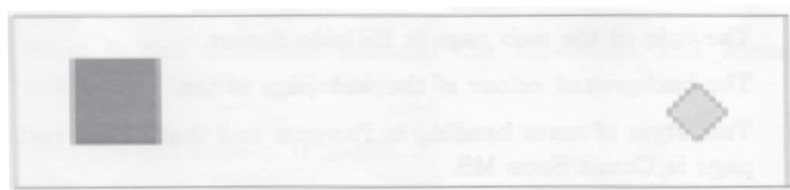

- The image on the left hand side shows the position and size for frame 1.
- The image on the right shows the image and size for frame 40.

- The shape on the left is blue in colour while the one on the right side is orange in colour.

Write the procedure and property settings for animating the above scenario.

- Ans
- **Select frame 1** from the timeline and select Insert a new Symbol> Graphic
  - Create the blue coloured square on the stage using the rectangle tool on the left hand side.
  - Insert an instance of this symbol in frame 1.
  - **Select frame 40** from the timeline and **Select Insert Keyframe**
  - Using the scale tool, **resize and rotate the square**
  - **Change the colour to orange** and place it on the right hand side of the stage at the desired location
  - **Select all frames from 1 to 40**
  - Open the tween panel and Ghoose **Create Shape Tween**

**OR Any other equivalent method**

*(1/2 mark for each step)* →

*Note: No marks to be deducted if only the highlighted portions from the above steps are written instead of writing complete sentences*

3. Answer the following questions based on HTML :

- (a) What is the difference between <FONT> and <BASEFONT> tags?

2

Ans The <FONT> tag is used to set the font characteristics for certain text elements whereas the <BASEFONT> tag is used to set the font characteristics for the entire web page.

**OR**

The <FONT> tag is used in the <BODY> section whereas the <BASEFONT> tag is specified in the <HEAD> section

**OR**

The <FONT> tag can have any number of occurrences whereas the <BASEFONT> tag is , specified only once in a web page.



(2 marks for anyone correct differentiation point between the two)

NOTE: 1 mark if usage of only one of the tags is explained

(b) Write the HTML code to generate the web page in the format shown:

8

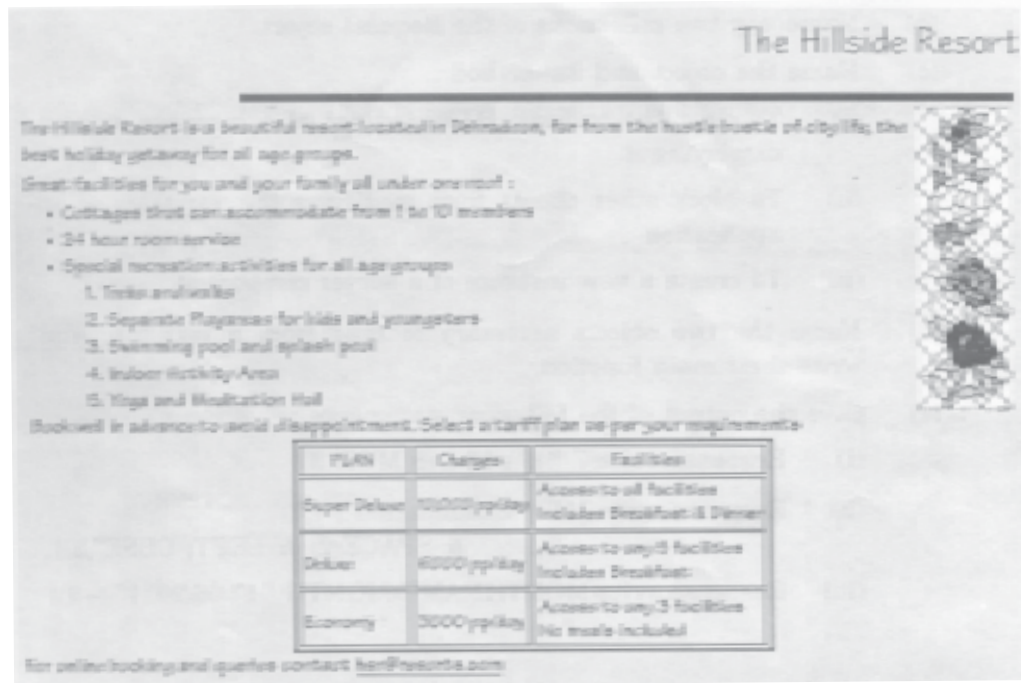

Consider the following points while writing the HTML code:

1. The title of the web page is Hillside Resort.
2. The background colour of the web page is tan.
3. Text style of main heading is Papyrus and that of the rest of the page is Comic Sans MS.
4. The image used is flowers.jpg
5. The line is green in colour and 6 pixels thick.
6. The table has a blue coloured border that is 4 pixels thick.
7. Use the concept of nested lists for creating the given list.
8. The link at the bottom is an e-mail link to the address [HSR@resorts.com](mailto:HSR@resorts.com)

Ans <HTML>

<HEAD>

```
<TITLE>The Hillside Resort</TITLE>
```

(½ mark)

```
</HEAD>
```

```
<BODY BGCOLOR="tan">
```

(½ mark)

```
<FONT FACE="papyrus">
```

(½ mark)

```
<H1 ALIGN="right">The hillside Resort</H1>
```

(½ mark)

```
<HR ALIGN="right" SIZE=6 WIDTH="80%" COLOR="green">
```

(1 mark)

```
<IMG SRC="flower.gif" ALIGN="right">
```

(1 mark)

```
<FONT FACE="comic sans ms">
```

The Hillside resort is a beautiful resort located in Dehradun, far from the hustle bustle of city life, the best holiday getaway for all age groups.

```
<P> Great facilities for you and your family all under one roof:
```

```
<BR>
```

```
<UL>
```

```
<LI> Cottages that can accommodate from 1 to 10 members
```

```
<LI> 24 hour room service
```

```
<LI> Special recreation activities for all age groups
```

```
<OL>
```

```
<LI> Treks and walks
```

```
<LI> Separate Playareas for kids and youngsters
```

```
<LI> Swimming pool and splash pool
```

```
<LI> Indoor Activity Area
```

```
<LI> Yoga and Meditation Hall
```

```
</OL>
```

```
</UL>
```

Book well in advance to avoid disappointment. Select a tariff plan as per your requirements

<CENTER>

<TABLE BORDER = 4 BORDERCOLOR="blue" CELLSPACING=2> (1mark)

<TR><TH>PLAN <TH>Charges<TH> Facilities

<TR>

<TD>Super Deluxe

<TD> 10000 pp/day

<TD> Access to all facilities <br> Includes Breakfast & Dinner

<TR>

<TD> Deluxe

<TD> 6000 pp/day

<TD> Access to any 5 facilities <br> Includes Breakfast

<TR>

<TD> Economy

<TD> 3000 pp/day

<TD> Access to any 3 facilities <br> No meals included

</TABLE>

</CENTER>

For online booking and queries contact

<A HREF="mailto: HSR@resorts.com">hsr@resorts.com</A> (1 mark)

</BODY> Conditional

</HTML> 1 mark

*(½ mark for correct use of <TITLE> tag)*

*+ (½ mark for body background colour)*

*+ (½ mark for mentioning the correct font type for either heading or web page)*

*+ (½ mark for displaying the heading correctly on the right)*

*+ (1 mark for drawing the horizontal line)*

- + (1 mark for displaying the image correctly on the right)
- + (1 mark for correctly creating the nested list (X mark for each list))
- + (1 mark for making table border 4 pixel thick with border color blue)
- + (1 mark for correctly creating the table using <TR> and <TD> tags)
- + (1 mark for correctly creating the email link on the text)

**Note: 1 mark to be awarded for correct use of <HTML> and <BODY> tags if any of the above mentioned tags are not given properly**

4 Answer the following questions based on ASP:

- (a) Give one reason why server side scripting is essential. 1

Ans. Server side scripting is essential to access data from a database residing on a server and accordingly respond to user queries.

**OR any other equivalent answer**

*(1 mark for mentioning the correct reason)*

- (b) Name any two collections of the Request Object. 1

Ans. Querystring / Form / Cookies / ServerVariables / ClientCertificate collection

*(1/2 mark each for any two above mentioned collections of the Request Object)*

- (c) Name the object and its method: 3

(i) To clear the buffered HTML output of a response without displaying it

(ii) To block other clients from modifying the variables of an application

(iii) To create a new instance of a server component ..

Ans (i) Object: Response Method: Clear

(ii) Object: Application Method: Lock

(iii) Object: Server Method: CreateObject

*(1/2 mark each for naming the Object and Method correctly for each part)*

- (d) Name the two objects necessary to read from a text file. Also write their main function. 2

Ans FileSystemObject and TextStream objects. The FileSystem object provides access from an ASP script to the file stored on the hard disk and the TextStream object allows the user to manipulate the contents of a text file.

*(1/2 mark each for naming the two objects)*

*+(1/2 mark each for the usage of each of the two objects)*

(e) Give the output of the following statements: 3

(i) Response.write(7 \* 6 - 121 ( 8 MOD 3 ))

(ii) Response.write(MID("Examination", 4,3) & SPACE(2) & LEFT("CBSE",2))

(iii) Response.write(MONTHNAME(MONTH("17/06/2011 ") +3))

Ans	<i>(Full 1 Mark)</i>	<i>( 1/2 Mark)</i>
i)	36	42 OR 2 OR 42 - 12/2
ii)	min CB OR min cb	min OR cb OR MIN OR CB
iii)	September	June

*(1 mark for each correct output of each part)*

*NOTE: 1/2 mark for any other partially correct answer*

5 Answer the following questions based on ASP:

(a) What is the difference between the MoveNext and MoveLast methods of the RecordSet object? 1

Ans. The MoveNext method moves the pointer to the next record in the database whereas the MoveLast method moves the pointer to the last record of the database.

*(1 mark for the correct differentiation)*

*Note: 1/2 mark if only usage of one of the methods is given*

(b) Give the full form of OLE-DB. 1

Ans Object Linking and Embedding for Databases

(1 mark for the correct expansion)

*NOTE: 1/2 mark if any two words are expanded correctly like Object Linking in DataBank*

(c) Predict the output of the following code:

2

```
<%  
DIM cnt,num  
List = ARRAY (30, 15, 25, 10, 20, 40, 12, 16)  
FOR cnt=0 to 6 STEP 2  
    Num= List (cnt) + List (cnt+1)  
    RESPONSE.WRITE(num & "<BR>")  
NEXT  
>%
```

Ans	(Full 2 Marks)	(1% Mark)
	45	45 35 60 28
	35	<b>OR</b>
	60	45356028
	28	

*(1/2 mark for each correct value of the output)*

*Note: 1/2 mark to be deducted if the numbers are given on the same line*

(d) Rewrite the following code after removing all errors and underline each correction:

2

```
<%  
DIM A = 30  
DO A > 0  
    SUM = SUM + F1 (A)  
    RESPONSE. DISPLAY ("SUM = " & SUM)  
    A = A - 10  
LOOP  
FUNCTION F1 (NUM)  
    F1 = NUM MOD 6  
END  
>%
```

Ans <%

DIM A

A = 30

DO WHILE A > 0

SUM = SUM + F1(A)

RESPONSE.WRITE ("SUM = " & SUM)

A = A - 10

LOOP

FUNCTION F1 (NUM)

F1 = NUM MOD 6

END FUNCTION

%>

Either the statement removed or both statements to be written on separate lines

(e) **BLOOM** cards uses banner advertisements to fund their web site as shown below

4

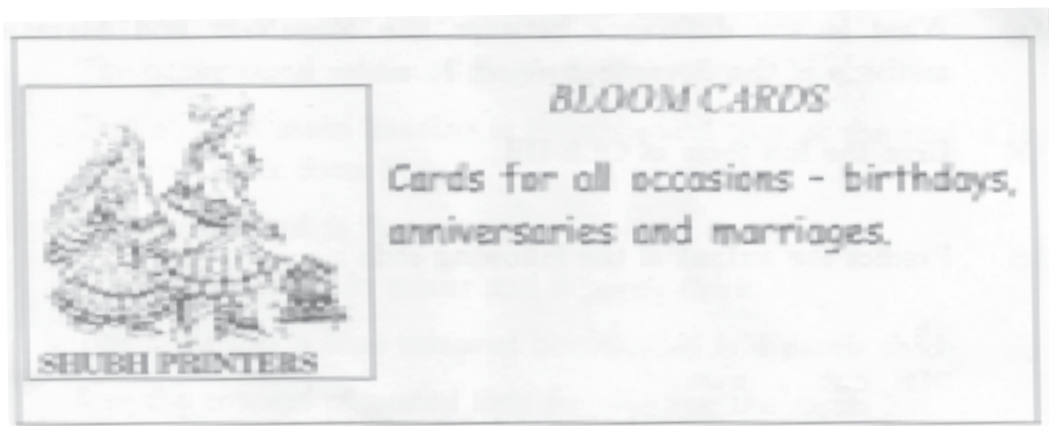

Create an ASP file "Greeting.asp" to display different banner advertisement on the web page. The ads to be displayed are stored in the file myads.txt.

Ans <HTML>

<BODY>

<CENTER> <H1>BLOOM CARDS</H1> </CENTER>

<HR>

<% Set myad=Server.CreateObject ("MSWC .AdRotator" )

% > OR Response. Write (myad. GetAdvertisement("myads. txt"))

<PALIGN="LEFT"><% = myad. GetAdvertisement ("myads. txt") 1%>

**Cards for all occasions - birthdays, anniversaries and marriages**

</BODY> </HTML>

*(1 mark for correct <H1> tag)*

*(1 mark for correct usage of CreateObject)*

*(1 mark for correct usage of GetAdverlisement)*

*(1 mark for displaying the text)*

6 Answer the following questions based on **VBSCRIPT**:

- (a) What is event handing? Name the event that occurs when the mouse cursor is brought over an element on a web page. 2

Ans The process of writing code for responding to an event is called event handing. The event is **OnMouseOver**.

*(1 mark for correct definition of the term)*

*(1 mark for correctly naming the event)*

- (b) Rewrite the following code using a **DO WHILE** instead of FOR loop without affecting the output: 2

<%

DIM prod

prod = 1

FOR n = 6 TO 1 step - 2

    Prod = prod \* 2

    RESPONSE. WRITE (prod & "<BR>")

NEXT

%>

Ans <%

DIM prod



```

prod = 1
n = 6
DO WHILE n>=1
    prod = prod * 2
    response.write(prod & "<br>")
    n = n - 2
LOOP
%>

```

OR Any other valid equivalent code

*(1/2 mark for making each of the four underlined conversions)*

(c) Predict the output of the following code:

2

```

<SCRIPT LANGUAGE="VBSCRIPT">
DIM S1 , S2, LEN1, LEN2
S1 = "Happy"
S2 = "Anniversary"
LEN1 = LEN(S1)
LEN2 = LEN(S2)
IF LEN2 MOD LEN1 = 0 THEN
    DOCUMENT.WRITE (S1 & S2)
ELSE
    DOCUMENT.WRITE (S2 & S1)
END IF
</ SCRIPT>

```

Ans Anniversary Happy

**OR**

Anniversary

Happy

OR

Anniversary Happy

*(1 mark for each correct underlined word in the output)*

*Note:*

- *1 mark if only one of the words is written like Anniversary or Happy*
- *No marks to be deducted for wrong case or for writing the output on separate lines*

(d) Write the **HTML** code to generate the following form:

4

**PTM DATE CHECK**

**Enter class of your ward:**

**PTM DATE :**

Write the VBScript code to display the PTM data on the click of the GET PTM DATE button as :

12/10/2012 if class entered is between 1 to 6 and

15/10/2012 if class is between 7 to 12

If the user enters any class other than the above then an error message should be displayed.

Ans <HTML>

```
<HEAD> <SCRIPT LANGUAGE="vbscript">
```

```
SUB b1_OnClick
```

```
    clas = f1.t1.value
```

```

SELECT CASE clas
CASE 1,2,3,4,5,6
    ptm="12/10/2012"
CASE 7,8,9,10,11,12
    ptm="15/10/2012"
CASE ELSE
    MSGBOX "Wrong Class"
END SELECT

```

OR

```

IF clas>=1 AND clas<=6
    ptm="12/10/2012"
ELSE IF clas>=7 AND clas <=12
    ptm="15/10/2012"
ELSE
    MSGBOX "Wrong Class"
END IF
END IF

```

```
f1.t2.value=ptm
```

```
END SUB
```

```
</SCRIPT> </HEAD>
```

```
<BODY>
```

```
<FORM NAME="f1"> <P ALIGN=CENTER>
```

```
<B>PTM DATE CHECK <P>
```

```
Enter class of your ward : <INPUT TYPE = "text" NAME="t1">
```

```
<BR><BR>
```

```
PTM DATE : <INPUT TYPE="TEXT" NAME = "t2">
```

```
<BRXBR> <CENTER>
```

```
<NPUT TYPE="BUTTON" VALUE="GET PTM DATE" NAME = "b1">
```

```
</FORM></BODY></HTML>
```

*(1/2 mark for the <FORM> tag)*

*(1/2 mark for creating the textbox)*

*(1/2 mark for creating the button)*

*(1/2 mark for associating the subroutine with the button element)*

*(1/2 mark for extracting the value and storing it in a variable)*

*(1 mark for the conditional statement - IF or SELECT CASE)*

*(1/2 mark for displaying the fee in the text box)*

*NOTE: No marks to be deducted if f1.t1.value/f1.t2.value is used in all places instead of using a variable*

7. (a) What is a network topology? 1

Ans The Physical arrangement of several computers is called a network topology

*(1 mark for the correct definition)*

(b) Name any two modes of wireless transmission media. 1

Ans Radio waves / Microwaves / Satellite/ Bluetooth / Infrared

*(1/2 mark each for naming any two wireless transmission media)*

(c) What are the following software used for : 2

(i) PHP

(ii) GNU

Ans (i) Open Source server side scripting language

(ii) Open Source Operating System

*(1 mark for giving the correct usage of each software for each part)*

(d) What is a firewall? What is its use? 2

Ans Firewall is a blocking mechanism.

**OR**

Firewall is used to secure a network.

*(2 mark for the correct definition or the correct usage)*

*Note: No marks to be deducted if conceat exalained with the help of an example*

(e) FurturZ Software Company has set up its new centre at New Delhi for its office and web based activities. It has 4 blocks of buildings as shown:

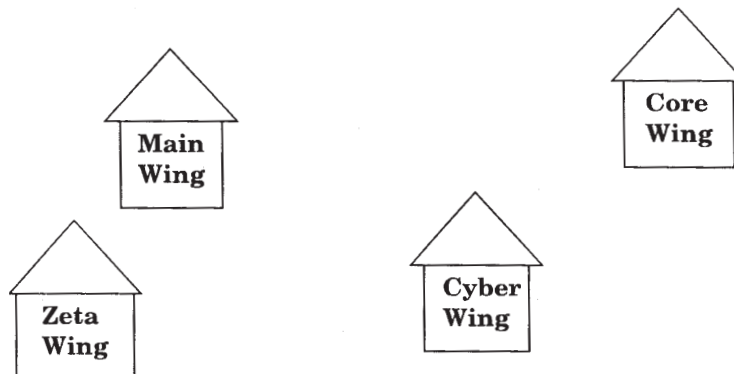

Centre to centre distances between various buildings is as follows

Main Wing to Zeta Wing	80 m
Zeta Wing to Cyber Wing	100 m
Cyber Wing to Core Wing	40 m
Main Wing to Cyber Wing	120 m
Zeta Wing to Core Wing	150 m
Main Wing to Core Wing	130 m

Number of Computers:

Main Win	50
Zeta Win	40
Cyber Win	250
Core Win	100

- (i) Suggest a cable layout of connections between buildings and name the topology used

1

Ans.

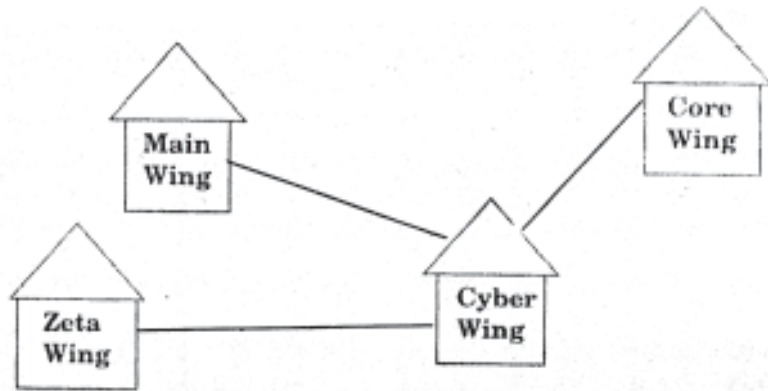

**OR**

Star topology is the most suitable.

*(1 Mark for drawing /writing any valid connectivity or topology or diagram connecting various buildings inside the company)*

**NOTE:** *Ignore placement/order of buildings in the diagrammatic representation*

- (ii) Suggest the most suitable place (Wing) to house the server of this-organization with a suitable reason.

1

Ans. Cyber Wing is the most suitable place to house the server as it has the maximum number of computers.

**OR**

Cyber Wing since it is closest to the other three buildings

*(½ Mark for writing correct place)*

*(½ Mark for correct justification)*

- (iii) Where should the repeaters be placed ?

1

Ans. Repeaters should be placed **between Cyber wing and Main Wing** and between Cyber **Wing and Zeta Wing** as the distance between them is greater than 75 m.

**OR**

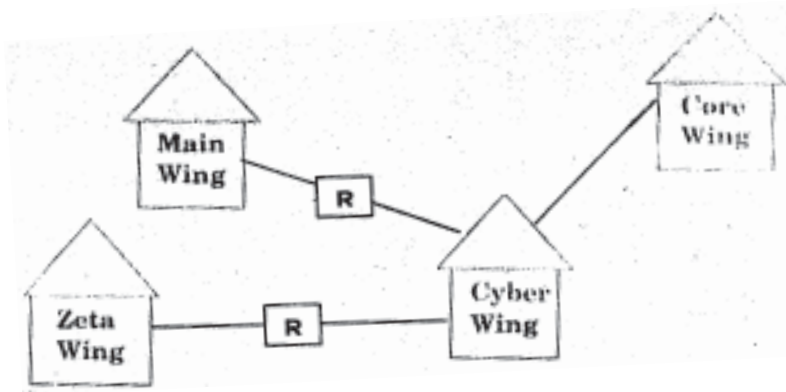

*(1 Mark for suggesting correct placement of the repeaters)*

- (iv) The parent company of FuturZ Software Company is situated in Hyderabad. Suggest the most economical method of linking the head office and this office that can provide fast communication.

1

Ans Radio waves

**OR**

TCP/IP or dial-up connection

*(1 mark for suggesting the most economical method)*